

## Task 25 (Part 2)

### Swimming Pools

There are various pools in a swimming centre.

Task:

- a) The volume of a particular cuboid-shaped swimming pool can be described by the equation  $V = a^2 \cdot h$ .

$a$  ... side length of the square base

$h$  ... depth of the swimming pool

The function  $V: \mathbb{R}^+ \rightarrow \mathbb{R}^+, a \mapsto V(a)$  with constant  $h$  and the function  $h: \mathbb{R}^+ \rightarrow \mathbb{R}^+, V \mapsto h(V)$  with constant  $a$  are to be considered.

- 1) Complete the gaps in the following sentence by putting a cross next to one of the given possibilities for each gap so that the sentence becomes a correct statement. [0/1/2/1 p.]

The function  $V$  is a ①; the function  $h$  is a ②.

①	
linear function	<input type="checkbox"/>
quadratic function	<input type="checkbox"/>
square root function	<input type="checkbox"/>

②	
linear function	<input type="checkbox"/>
quadratic function	<input type="checkbox"/>
square root function	<input type="checkbox"/>

- b) In order to fill another swimming pool,  $p$  pumps are used, which each pump the same amount of water into the swimming pool per hour. For  $p = 2$ , the filling time is 19 h.

- 1) Using the number  $p$  of pumps, write down a formula that can be used to calculate the filling time  $T$  (in h).

$T =$  \_\_\_\_\_ [0/1 p.]

The amount of water in this swimming pool decreases due to evaporation and operational causes. The function  $W: [0, 10] \rightarrow \mathbb{R}$  with  $W(t) = -\frac{1}{96} \cdot t^3 + \frac{1}{4} \cdot t^2 - \frac{35}{24} \cdot t$  models the instantaneous rate of change of the amount of water at time  $t$  on a particular day ( $t$  in h,  $W(t)$  in  $\text{m}^3/\text{h}$ ).

- 2) Determine the reduction in the amount of water (in  $\text{m}^3$ ) in the time interval  $[0, 6]$ . [0/1 p.]

c) The diagram below models the side-on profile of a particular water slide.

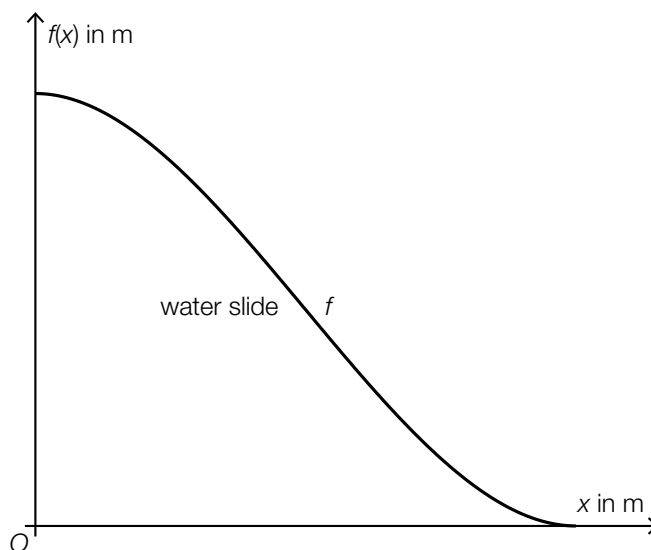

The side-on profile of the water slide is given by the function  $f: [0, 5] \rightarrow \mathbb{R}$  with

$$f(x) = \frac{8}{125} \cdot x^3 - \frac{12}{25} \cdot x^2 + 4 \quad (x \text{ in m, } f(x) \text{ in m}).$$

- 1) Determine the  $x$ -coordinate  $x_1$  of the point at which the water slide is decreasing most steeply.

[0/1 p.]

## Task 26 (Part 2, Best-of Assessment)

### Fitness Watches

Fitness watches are wristwatches that can be used during sports activities.

Task:

- a) A 3.1 km mountain hike goes from the start at 680 m above sea level to a hut at the summit at 1 820 m above sea level. The distance covered is modelled as a straight line with a constant gradient and is shown in the (not-to-scale) sketch below.

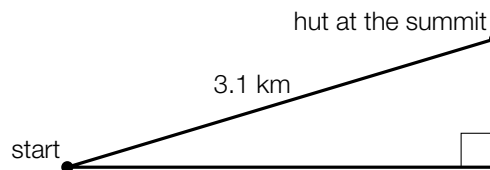

The path of the mountain hike has a gradient of  $a$  %.

- 1) Determine  $a$ .

$a =$  \_\_\_\_\_ %

[0/1 p.]

- b) The fitness watch *Sporty* is particularly popular. The probability that a randomly chosen person in Austria possesses a *Sporty* fitness watch is  $p$ .

In the course of a study, 160 randomly chosen people in Austria are surveyed.

The binomially distributed random variable  $X$  gives the number of people out of the 160 people surveyed who possess a *Sporty* fitness watch.

- 1) Complete the gaps in the following sentence by putting a cross next to one of the given possibilities for each gap so that the sentence becomes a correct statement. [0/½/1 p.]

The probability that none of the 160 people surveyed possesses a *Sporty* fitness watch is \_\_\_\_\_ ① \_\_\_\_\_; the probability that at least 2 of the 160 people surveyed possess a *Sporty* fitness watch is \_\_\_\_\_ ② \_\_\_\_\_.

①	
$1 - p$	<input type="checkbox"/>
$p^{160}$	<input type="checkbox"/>
$(1 - p)^{160}$	<input type="checkbox"/>

②	
$1 - \left[ \binom{160}{0} \cdot p^0 \cdot (1 - p)^{160} + \binom{160}{1} \cdot p \cdot (1 - p)^{159} \right]$	<input type="checkbox"/>
$\binom{160}{0} \cdot p^0 \cdot (1 - p)^{160} + \binom{160}{1} \cdot p \cdot (1 - p)^{159}$	<input type="checkbox"/>
$\binom{160}{2} \cdot p^2 \cdot (1 - p)^{158}$	<input type="checkbox"/>

- c) Fitness watches show, among other things, the calories burned during a sports activity. In the course of a study, the percentage deviation of the actual calories burned for a sports activity from the corresponding value measured by the fitness watch was investigated for 60 people. These deviations along with their corresponding absolute frequencies are summarized in classes in the table below.

deviation in %	absolute frequency
[0, 20)	24
[20, 30)	30
[30, 50]	6

- 1) Construct a histogram that represents the relative frequencies for the three classes shown above as areas of rectangles. [0/1 p.]

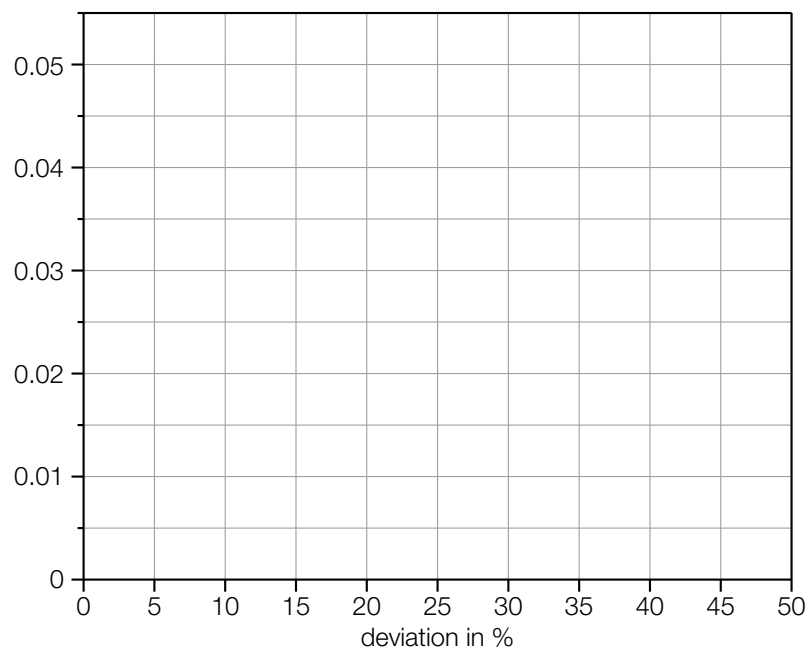

- 2) Justify why the median of the list of data (that forms the basis of the table above) has to lie in the interval [20, 30). [0/1 p.]

## Task 27 (Part 2, Best-of Assessment)

### Oxygen Consumption in Mammals

For mammals, there is a relationship between the body mass and the oxygen consumption.

Task:

- a) For a mammal that does not move during the observation period, the oxygen consumption can be approximated by a function  $S: \mathbb{R}^+ \rightarrow \mathbb{R}^+$ ,  $m \mapsto S(m)$  in terms of the body mass  $m$  ( $m$  in kg,  $S(m)$  in L/h).

For cats and dogs with a body mass  $m$ , the following equation holds:

$$S(m) = a \cdot m^{0.75}$$

$a$  ... positive constant

The body mass of a particular dog is twice as big as that of a particular cat.

- 1) Determine the percentage by which the oxygen consumption of this dog is higher than that of this cat. [0/1 p.]

- b) The function  $I: \mathbb{R}^+ \rightarrow \mathbb{R}^+$  describes the metabolic intensity of mammals in terms of their body mass  $m$  ( $m$  in kg,  $I(m)$  in  $\frac{\text{L}}{\text{h} \cdot \text{kg}}$ ).

The graph of  $I$  is shown in the diagram below.

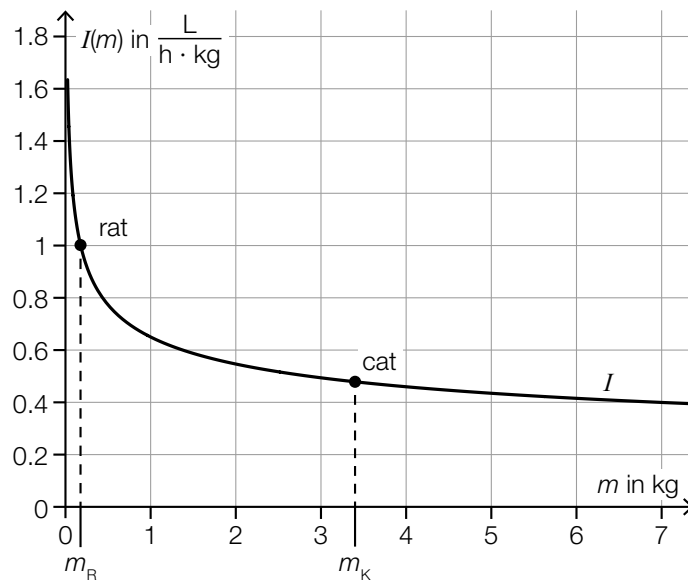

Source: Sadava, David E., David M. Hillis et al.: *Purves Biologie*. Edited by Jürgen Markl. 10<sup>th</sup> ed. Berlin et al.: Springer 2019, p. 1201 (adapted).

The body mass of a rat is given by  $m_R$  and that of a cat is given by  $m_K$ .

For a particular body mass  $m_1$ ,  $I'(m_1)$  is equal to the average rate of change of  $I$  in the interval  $[m_R, m_K]$ .

- 1) Determine  $m_1$  using the diagram above.

$m_1 =$  \_\_\_\_\_ kg

[0/1 p.]

- c) For a mammal that is moving, the instantaneous rate of change of the oxygen consumption can be approximated in terms of the time  $t$  by the linear function  $u: [0, t_1] \rightarrow \mathbb{R}$  with  $t_1 \in \mathbb{R}^+$  ( $t$  in min,  $u(t)$  in L/min).

$u(0) = d$  with  $d \in \mathbb{R}^+$  holds.

The graph of  $u$  is shown in the diagram below.

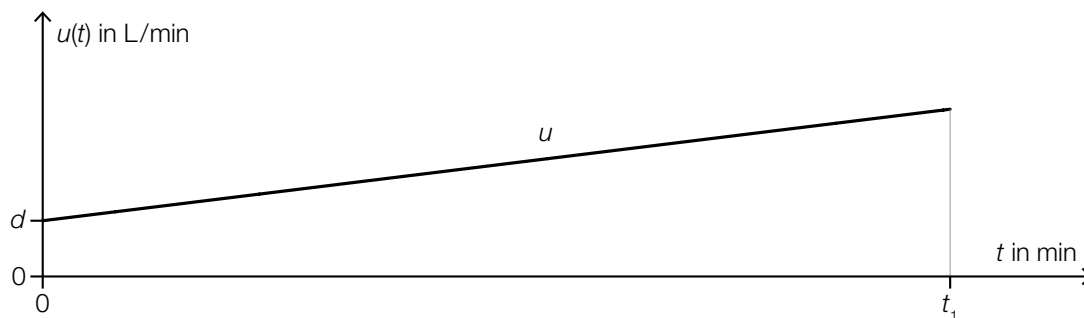

- 1) Write down a formula that can be used to calculate  $\int_0^{t_1} u(t) dt$ . For this formula, use  $t_1$ ,  $u(t_1)$  and  $d$ .

$$\int_0^{t_1} u(t) dt = \underline{\hspace{15em}} \quad [0/1 p.]$$

- 2) Interpret  $\int_0^{t_1} u(t) dt$  in the given context, including the corresponding unit. [0/1 p.]

## Task 28 (Part 2, Best-of Assessment)

### Flights

At Austrian airports, data on the number of flights, the number of passengers as well as the routes of the passengers is collected.

Data source: [https://www.statistik.at/web\\_de/statistiken/energie\\_umwelt\\_innovation\\_mobilitaet/verkehr/luftfahrt/personenverkehr/index.html](https://www.statistik.at/web_de/statistiken/energie_umwelt_innovation_mobilitaet/verkehr/luftfahrt/personenverkehr/index.html) [19.12.2020].

#### Task:

- a) The annual number of all passengers in Austria increased from 0.14 million in the year 1955 to 28.95 million in the year 2017.

This development of the number of passengers in Austria over time can be approximated by the exponential function  $N: \mathbb{R}_0^+ \rightarrow \mathbb{R}^+$  with  $N(t) = a \cdot b^t$  with  $a, b \in \mathbb{R}^+$  ( $t$  in years with  $t = 0$  for the year 1955,  $N(t)$  in millions of passengers).

- 1) Determine  $a$  and  $b$ .

[0/1 p.]

In the year 2018, there were 31.73 million passengers in Austria.

- 2) Show by calculation that the number of passengers given by  $N$  for the year 2018 deviates from the actual number by less than 1 %.

[0/1 p.]

- b) The number of flights and passengers in Austria for the years 2018 and 2019 are shown in the table below.

	number of flights	number of passengers
2018	296 852	31 725 019
2019	319 945	36 206 642

The average number of passengers per flight increased by  $n$  from 2018 to 2019.

- 1) Determine  $n$ .

[0/1 p.]



- c) The diagram below shows the number of seats available as well as the number of passengers for flights to and from Vienna for the year 2019. The percentages give the relative proportion of seats occupied by passengers.

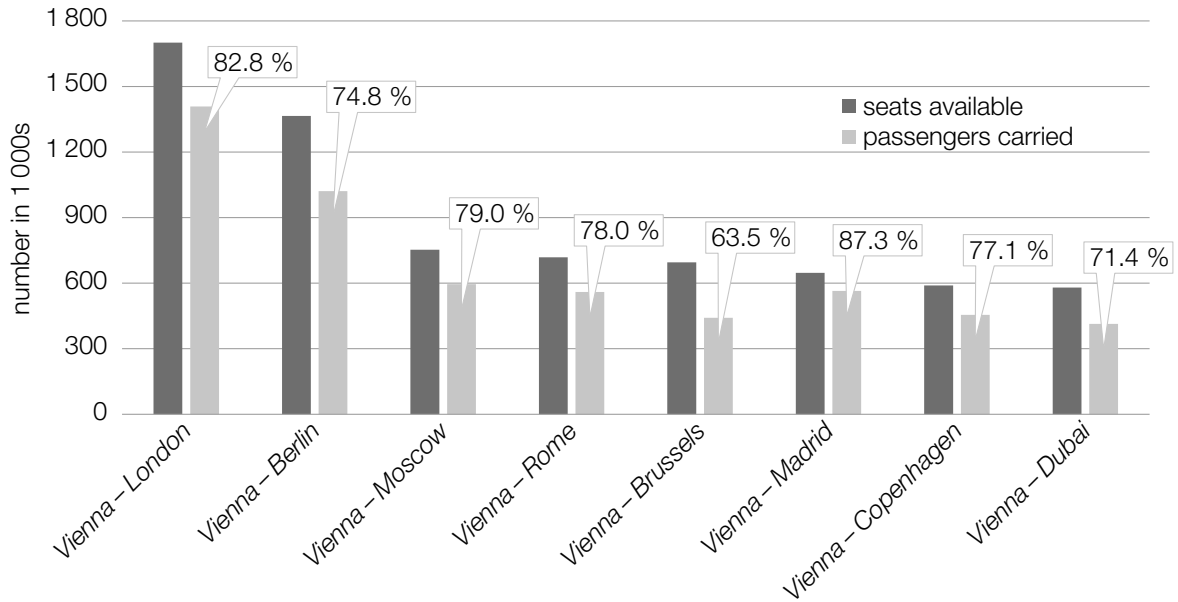

- 1) Match each of the four statements for the year 2019 to the corresponding route from A to F.

[0/½/1 p.]

On this route, more than twice as many passengers were carried than on the <i>Vienna-Moscow</i> route.	
On this route, the number of unoccupied seats was the smallest.	
On this route, the number of passengers carried was greater than 650000 and smaller than 1.1 million.	
On this route, more than one third of the seats available were unoccupied.	

A	<i>Vienna-Berlin</i>
B	<i>Vienna-Madrid</i>
C	<i>Vienna-Brussels</i>
D	<i>Vienna-Copenhagen</i>
E	<i>Vienna-London</i>
F	<i>Vienna-Rome</i>

## Task 25 (Part 2)

### Triathlon

*Triathlon* is a competition in which sportspeople complete a swimming race, a cycling race and a running race in exactly this order.

Task:

- a) The path of the swimming race of a particular triathlon is modelled in the diagram below. The swimming race starts at point  $S$  and ends at point  $Z$ . Between these points, the checkpoints  $B_1, B_2, B_3, S, B_1$  and  $B_2$  must be passed in exactly this order.

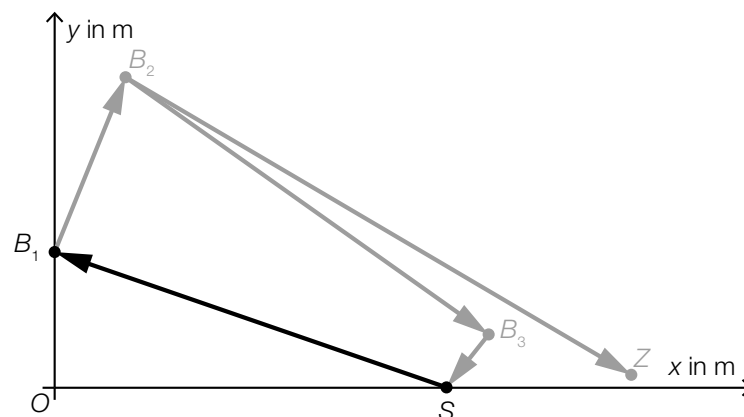

The distance from point  $S = (600, 0)$  to point  $B_1$  is 700 m.

- 1) Determine the  $y$ -coordinate of  $B_1$ .

$$B_1 = (0, \boxed{\phantom{000}})$$

[0/1 p.]

- b) In the cycling race of a particular triathlon, Stefanie starts 1.45 min before Tanja.

$t$  ... time in min

$t = 0$  ... time at which Stefanie starts

$v_{\text{Stefanie}}(t)$  ... Stefanie's velocity at time  $t$  in km/min

$v_{\text{Tanja}}(t)$  ... Tanja's velocity at time  $t$  in km/min

Stefanie completes the cycling race in 291 min. At this time, Tanja is still cycling.

- 1) Interpret what can be calculated by the expression shown below in the given context.

$$\int_0^{291} v_{\text{Stefanie}}(t) dt - \int_{1.45}^{291} v_{\text{Tanja}}(t) dt$$

[0/1 p.]

c) Michael takes part in a particular triathlon.

Michael starts the final 42.195 km long running race with a total time of 5 h 12 min 38 s up to that point.

Michael finishes the triathlon with a total time of 7 h 36 min 56 s.

1) Determine Michael's average speed in the running race in km/h. [0/1 p.]

d) The most famous triathlon competition is the *Ironman World Championship* in Hawaii.

The function  $f: \mathbb{N} \rightarrow \mathbb{R}$  with  $f(t) = 0.1275 \cdot t^3 - 8.525 \cdot t^2 + 198.425 \cdot t + 15$  models the number of participants in this competition in terms of time  $t$  in the period from 1978 to 2018 ( $t$  in years with  $t = 0$  for the year 1978).

Source: [https://www.tri226.de/ironman-ergebnisse.php?language=ge&table=start\\_finish](https://www.tri226.de/ironman-ergebnisse.php?language=ge&table=start_finish) [09.08.2022].

The number of participants in this competition increased by an average of  $n$  people per year from 1978 to 2018.

1) Determine  $n$ . [0/1 p.]

## Task 26 (Part 2, Best-of Assessment)

### Ludo

*Ludo* is a board game for at least two people. The aim of the game is to move your 4 playing pieces of the same colour from the starting position to the finishing position as quickly as possible.

#### Task:

- a) There are 4 red, 4 yellow and 4 blue playing pieces for Ludo in a material bag. Isabella removes 4 playing pieces at random and without replacement.

- 1) Determine the probability that all 4 of the playing pieces removed are red. [0/1 p.]

Isabella has removed all of the red playing pieces. Therefore, the material bag now contains only the 4 yellow and 4 blue playing pieces.

Now Fatima removes 1 playing piece at a time, without replacement, until she has removed all 4 yellow playing pieces.

The random variable  $X$  describes the number of draws  $k$  that Fatima requires until she has drawn all 4 yellow playing pieces. The probability distribution of the random variable  $X$  is shown in the table below.

$k$	4	5	6	7	8
$P(X = k)$	$\frac{1}{70}$	$u$	$\frac{10}{70}$	$\frac{20}{70}$	$v$

- 2) Determine  $u$  and  $v$ .

$$u = \underline{\hspace{10cm}}$$

$$v = \underline{\hspace{10cm}}$$

[0/1 p.]

- b) Isabella wins an average of 3 out of 5 games of Ludo against her friend Fatima. In the upcoming summer holidays, the two girls will play  $n$  games against each other ( $n$  is even,  $n > 2$ ).

The binomially distributed random variable  $Y$  gives the number of games out of  $n$  that will be won by Isabella.

Four probabilities and six events are shown below.

- 1) Match each of the four probabilities to the event that occurs with that probability from A to F. [0/1/2/1 p.]

$\binom{n}{\frac{n}{2}} \cdot 0.6^{\frac{n}{2}} \cdot 0.4^{\frac{n}{2}}$	
$1 - 0.4^n - n \cdot 0.6 \cdot 0.4^{n-1}$	
$1 - 0.6^n$	
$n \cdot 0.6^{n-1} \cdot 0.4$	

A	Isabella wins exactly half of the $n$ games.
B	Isabella wins at least 2 of the $n$ games.
C	Isabella loses more than half of the $n$ games.
D	Isabella loses exactly 1 of the $n$ games.
E	Isabella loses at least 1 of the $n$ games.
F	Isabella wins at most 1 of the $n$ games.

The expectation value of  $Y$  is given by  $\mu$ ; the standard deviation of  $Y$  is given by  $\sigma$ .

- 2) Determine the probability  $P(\mu - \sigma < Y < \mu + \sigma)$  for  $n = 14$ .

[0/1 p.]

## Task 27 (Part 2, Best-of Assessment)

### Beekeeping in Austria

The table below shows the number of beekeepers and their bee colonies in Austria in the time from 2015 to 2019.

year	number of beekeepers	number of bee colonies
2015	26 063	347 128
2016	26 609	354 080
2017	27 580	353 267
2018	28 432	373 412
2019	30 237	390 607

Source: <https://www.biene-oesterreich.at/daten-und-zahlen+2500++1000247> [10.08.2020].

#### Task:

- a) Maja completes the following calculation using values from the table above:

$$\frac{353\,267}{27\,580} \approx 13$$

- 1) Interpret the result of this calculation in the given context.

[0/1 p.]

- b) The number of beekeepers in Austria is modelled in terms of time  $t$  by the quadratic function  $f$  of the form  $f(t) = c \cdot t^2 + d$  with  $c, d \in \mathbb{R}$  ( $t$  in years with  $t = 0$  for the year 2015). The values of the function of  $f$  match the values in the table above for the years 2015 and 2019.

- 1) Determine  $c$  and  $d$ .

[0/1 p.]

- c) Lower temperatures lead to winter mortality among the bee colonies. The number of bee colonies would reduce by an average of 16 % per year without the beekeepers breeding new colonies.

The number of bee colonies that would exist in Austria if there were no extra breeding is described by the exponential function  $g$ .

The following conditions hold:

$t$  ... time in years with  $t = 0$  for the year 2015

$g(t)$  ... number of bee colonies in Austria at time  $t$

- 1) Write down an equation of the function  $g$ .

$g(t) =$  \_\_\_\_\_ [0/1 p.]

- 2) Determine the time it would take for the number of bee colonies in Austria to halve according to the exponential function  $g$ . [0/1 p.]

## Task 28 (Part 2, Best-of Assessment)

### Pond

There are  $129 \text{ m}^3$  of water in an artificial pond.

#### Task:

- a) The pond can be completely emptied through two drains.

If only one drain is opened, then the complete drainage of the pond takes 10 h.

If only the other drain is opened, then the complete drainage of the pond takes 6 h.

Each of the drainage velocities is constant over the whole time period.

The time it takes for the pond to be completely drained when both drains are opened at the same time is given by  $T$ .

- 1) Determine  $T$ .

[0/1 p.]

- b) The completely empty pond is filled again with  $129 \text{ m}^3$  of water.

The function  $d: \mathbb{R}^+ \rightarrow \mathbb{R}^+$  gives the filling time  $d(z)$  in terms of the constant inflow velocity  $z$  ( $z$  in  $\text{m}^3/\text{h}$ ,  $d(z)$  in h).

- 1) Write down an equation of the function  $d$ .

$$d(z) = \underline{\hspace{15em}}$$

[0/1 p.]

The function  $h$  describes the height of the surface of the water above the deepest point of the pond in terms of the time  $t$  for a constant inflow velocity  $z = 6 \text{ m}^3/\text{h}$  ( $t$  in h,  $h(t)$  in m).

The following holds for the instantaneous rate of change of the height of the surface of the water:

$$h'(t) = \frac{15}{\sqrt{2738 \cdot \pi \cdot t}} \quad \text{with } t > 0$$

- 2) Determine by how many metres the height of the surface of the water rises in the last 10 h of filling.

[0/1 p.]



c) The amount of water in the pond changes due to rain and evaporation.

The function  $w: [0, 12] \rightarrow \mathbb{R}$  approximates the instantaneous rate of change of the amount of water in the pond in terms of the time  $t$  ( $t$  in h,  $w(t)$  in L/h).

The diagram below shows the graph of  $w$ .

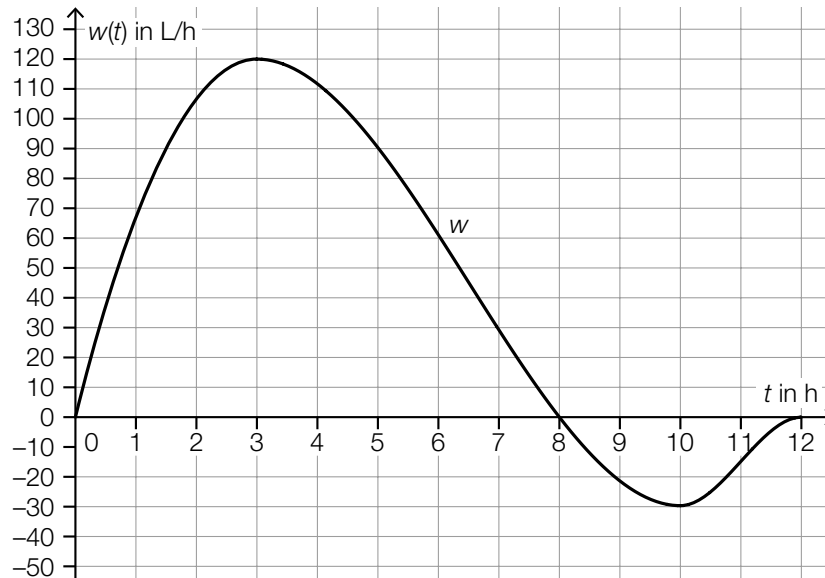

1) Match each of the four statements to the corresponding largest possible time period from A to F. [0/1/2/1 p.]

The amount of water in the pond is decreasing.	
The amount of water in the pond is increasing faster and faster.	
The instantaneous rate of change of the amount of water in the pond is decreasing.	
The amount of water in the pond is increasing.	

A	(0, 3)
B	(3, 10)
C	(8, 12)
D	(3, 12)
E	(8, 10)
F	(0, 8)

## Task 25 (Part 2)

### Flights

Task:

- a) In Austria in 2018, the parking fees near the airports listed below were different.

airport	parking fees per week in euros
Klagenfurt	$K$
Salzburg	54
Linz	$L$
Graz	$G$
Vienna-Schwechat	$W$
Innsbruck	147

Source: <https://www.derstandard.at/story/2000079383984/ranking-wo-das-parken-teurer-ist-als-der-flug> [09.08.2022].

- 1) Determine the percentage by which the parking fees per week at Innsbruck airport were higher than the fees at Salzburg airport. [0/1 p.]

The mean of these 6 parking fees is  $D$  (in euros).

- 2) Write down a formula that can be used to calculate the parking fees  $G$  at Graz airport in terms of  $D$  and the entries in the table above.

$G =$  \_\_\_\_\_ [0/1 p.]

- b) An airplane accelerates along the runway and takes off after 32 s. The velocity of the airplane is modelled by a linear function  $v$  in terms of the time  $t$ . The graph of the function  $v$  is shown in the diagram below.

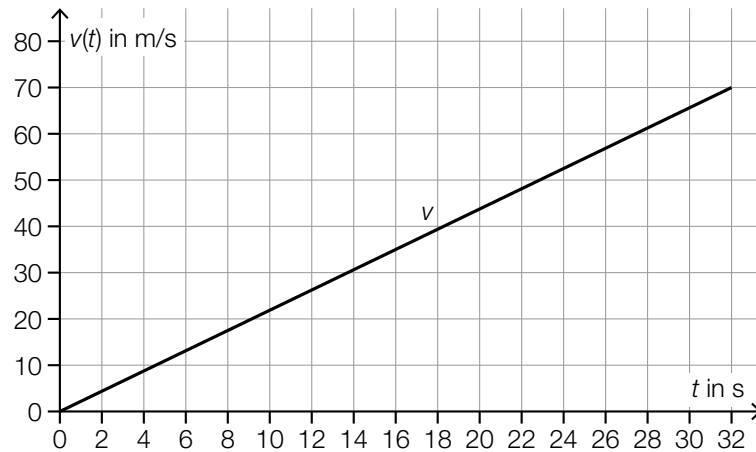

- 1) Determine the distance traveled by the airplane before take-off in metres. [0/1 p.]

- c) For a particular flight, 124 people have booked a seat.

It is assumed that the seats booked on a flight are occupied by passengers independently of each other with the probability  $p$ .

The probability of the event  $E$  is given by:

$$P(E) = 1 - \binom{124}{123} \cdot p^{123} \cdot (1-p) - \binom{124}{124} \cdot p^{124}$$

- 1) Complete the gaps in the following sentence by putting a cross next to one of the given possibilities for each gap so that the sentence becomes a correct statement. [0/1 p.]

The event  $E$  is: “ \_\_\_\_\_ ① \_\_\_\_\_ ② \_\_\_\_\_ of the seats booked are occupied.”

①	
At most	<input type="checkbox"/>
Exactly	<input type="checkbox"/>
At least	<input type="checkbox"/>

②	
122	<input type="checkbox"/>
123	<input type="checkbox"/>
124	<input type="checkbox"/>

## Task 26 (Part 2, Best-of Assessment)

### Passwords

Passwords are comprised of symbols in a pre-defined order. In a password, symbols can appear more than once.

The number of characters in a password is defined as the password length  $k$  ( $k \in \mathbb{N}$ ,  $k \geq 2$ ). For each of these characters, a symbol is chosen out of  $n$  different symbols ( $n \in \mathbb{N}$ ,  $n \geq 2$ ).

The number  $A$  of all possible passwords can be calculated using the formula  $A = n^k$ .

#### Task:

- a) A particular computer can check 1 billion passwords per second. In order to check  $n^k$  passwords, the computer requires  $t$  hours.

- 1) Write down a formula in terms of  $k$  and  $n$  that can be used to calculate  $t$ .

$$t = \underline{\hspace{15em}}$$

[0/1 p.]

This formula that can be used to calculate  $t$  can be written as a function of  $k$  and  $n$ .

- 2) Complete the gaps in the following sentence by putting a cross next to one of the given possibilities for each gap so that the sentence becomes a correct statement. [0/1½/1 p.]

If  $k$  is constant, then  $t$  in terms of  $n$  is  $\text{\textcircled{1}}$ ; if  $n$  is constant, then  $t$  in terms of  $k$  is  $\text{\textcircled{2}}$ .

\text{\textcircled{1}}	
a linear function	<input type="checkbox"/>
a power function	<input type="checkbox"/>
an exponential function	<input type="checkbox"/>

\text{\textcircled{2}}	
a linear function	<input type="checkbox"/>
a power function	<input type="checkbox"/>
an exponential function	<input type="checkbox"/>

- b) The password to access a particular website is created automatically by a random password generator. The random password generator chooses each symbol from 26 letters and 10 digits ( $n = 36$ ) independently of the other symbols and with equal probability. The password length is 8 symbols ( $k = 8$ ).
- 1) Determine the probability that the password only contains letters. *[0/1 p.]*
  - 2) Determine the probability that the password contains at most 1 digit. *[0/1 p.]*

## Task 27 (Part 2, Best-of Assessment)

### Dogs in Austria

Dogs are very popular pets in Austria.

Task:

- a) The diagram below shows the distribution of the number of dogs in Austria by federal state in the year 2018.

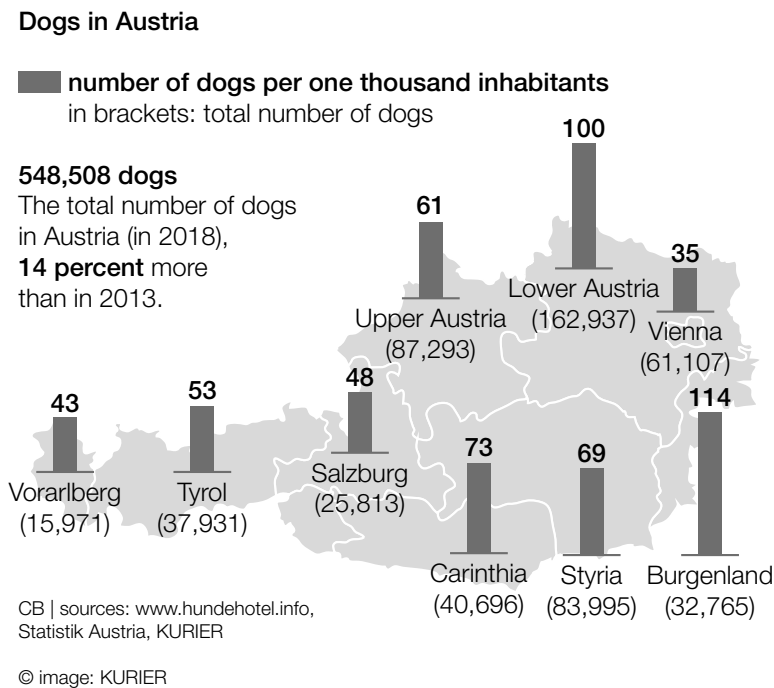

Image source: <https://kurier.at/chronik/oesterreich/plus-14-prozent-hunde-liegen-voll-im-trend/400573877> [16.03.2021] (adapted).

The median number of dogs per one thousand inhabitants in the 9 federal states is equal to the number of dogs per one thousand inhabitants in one particular federal state.

- 1) Write down this federal state.

[0/1 p.]

- b) The diagram below shows the development of the masses of dogs of different sizes in the first 17 months of life.

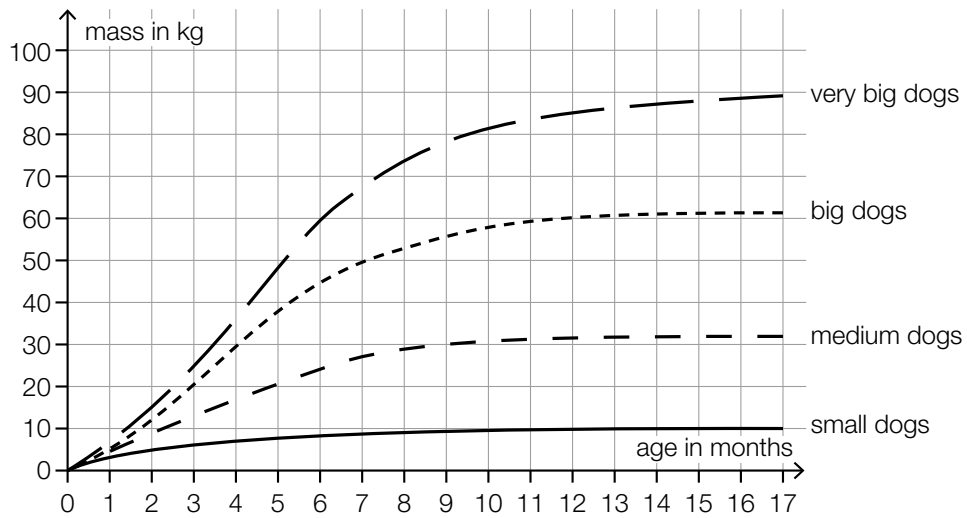

Source: <https://www.dasgesundetier.de/magazin/artikel/welpenerziehung-teil-2> [15.03.2021] (adapted).

- 1) Complete the two sentences below using the data from the diagram above so that they become correct statements. [0/1/2/1 p.]

“Big dogs” have a mass of around \_\_\_\_\_ kg at an age of 4 months.

“Very big dogs” have a mass of 80 kg at an age of around \_\_\_\_\_ months.

c) A *Labrador* is a breed of dog.

The *minimum mass* is the smallest mass that a healthy female Labrador should have at a given age.

The table below shows the minimum masses of female Labradors in terms of age.

age in months	3	4	5	6	7	8	9	10	11	12
minimum mass in kg	10	13	16	18	20	22	22	23	24	24

Data source: <https://tierpal.de/labrador-wachstum/> [06.09.2022].

It can be assumed that the minimum masses of female Labradors grow linearly between the ages of 1 and 5 months.

1) Determine the percentage by which the minimum mass of female Labradors increases between the ages of 2 and 3 months. [0/1 p.]

The minimum masses of female Labradors between the ages of 7 and 15 months can be modelled by the function  $m: [7, 15] \rightarrow \mathbb{R}^+$ .

$$m(t) = 25 - 24.7 \cdot e^{-k \cdot t} \text{ with } k \in \mathbb{R}^+$$

$t$  ... age in months

$m(t)$  ... minimum mass at age  $t$  in kg

For the age of 7 months, the value of the function  $m$  matches the corresponding value in the table.

For the age of 12 months, the value of the function  $m$  deviates from the corresponding value in the table above.

2) Determine this deviation in kg. [0/1 p.]



## Task 28 (Part 2, Best-of Assessment)

### Growth of Animal Populations

Task:

- a) The size of the population (number of individuals) of a particular animal species can be modelled by the function  $N: \mathbb{R}_0^+ \rightarrow \mathbb{R}^+$  in terms of the time  $t$ .

For this model, the following information is given:

$$N(t) = \frac{500}{1 + 4 \cdot e^{-0.2 \cdot t}}$$

$t$  ... time in weeks

$N(t)$  ... size of the population at time  $t$

At time  $t_v$ , the population has doubled in size since the time  $t = 0$ .

- 1) Determine  $t_v$ .

[0/1 p.]

- b) The speed of growth of a different animal population can be modelled by the polynomial function  $f$  with  $f(t) = a \cdot t^2 + b \cdot t + c$  with  $a, b, c \in \mathbb{R}$  and  $a \neq 0$ . The instantaneous rate of change of the number of individuals in terms of the time  $t$  is given by  $f(t)$  ( $t$  in weeks,  $f(t)$  in individuals per week).

The speed of growth at time  $t = 0$  is 15 individuals per week and reaches a maximum after 7 weeks. After 35 weeks, the speed of growth is 0 individuals per week.

- 1) Write down an equation of the function  $f$ .

$f(t) =$  \_\_\_\_\_ [0/1 p.]

It is assumed that the animal population comprises 50 individuals at the beginning of the observations.

- 2) Interpret  $50 + \int_0^7 f(t) dt$  in the given context. [0/1 p.]

One of the expressions below describes the average rate of change of the size of the animal population in the time interval  $[t_1, t_2]$  with  $t_1 < t_2$ .

- 3) Put a cross next to the expression that is always correct. [1 out of 6] [0/1 p.]

$\frac{f(t_2) - f(t_1)}{t_2 - t_1}$	<input type="checkbox"/>
$\frac{\int_{t_1}^{t_2} f(t) dt}{t_2 - t_1}$	<input type="checkbox"/>
$\int_0^{t_1} f(t) dt - \int_0^{t_2} f(t) dt$	<input type="checkbox"/>
$\frac{f(t_2) - f(t_1)}{t_2}$	<input type="checkbox"/>
$f(t_2) - f(t_1)$	<input type="checkbox"/>
$\frac{f(t_2) - f(t_1)}{f(t_1)}$	<input type="checkbox"/>

## Task 25 (Part 2)

### Bicycle Ride

Task:

- a) Bettina goes on a 2-hour bicycle ride. Her velocity can be approximated by the function  $v$ .

$$v(t) = -0.08 \cdot t^2 + 16 \quad \text{with } 0 \leq t \leq 2$$

$t$  ... time in h with  $t = 0$  at the start of the bicycle ride

$v(t)$  ... velocity at time  $t$  in km/h

- 1) Determine the amount of time Bettina needs to complete the first 10 km of this bicycle ride. [0/1 p.]
- 2) Determine her acceleration at time  $t = 1$ . Write down the corresponding unit. [0/½/1 p.]

- b) The recommended tyre pressure for a bicycle tyre decreases as the width of the tyre increases. The recommended tyre pressure from 2 bar to 9 bar can be approximated by the function  $p$ .

$$p(x) = 19.1 \cdot e^{-0.0376 \cdot x}$$

$x$  ... width of the tyre in mm

$p(x)$  ... recommended tyre pressure for a width of  $x$  in bar

- 1) Determine the largest possible interval for the width of a tyre whose recommended tyre pressure is between 2 bar and 9 bar. [0/1 p.]
- 2) Interpret the result of the calculation shown below in the given context and write down the corresponding unit. [0/1 p.]

$$p(30) - p(20) \approx -2.8$$

## Task 26 (Part 2, Best-of Assessment)

### Biathlon

Biathlon is a type of winter sport that combines cross-country skiing and shooting.

In a particular competition, three 2 500 m rounds must be completed.

The rules are as follows:

- After each of the first and second rounds, there is a shooting round in which five shots are taken.
- For every shot that misses the target, a 150 m penalty round must be completed, which leads to a loss of time.

Source: <https://www.sport1.de/wintersport/biathlon/2018/11/biathlon-im-ueberblick-regeln-disziplinen-wissenswertes> [15/04/2021].

#### Task:

a) Lisa completes the three rounds with the following average speeds ( $v_1$ ,  $v_2$ ,  $v_3$  in m/s):

- $v_1$  for the first round
- $v_2$  for the second round
- $v_3$  for the third round

For each shooting event, Lisa needs a time of  $t^*$  ( $t^*$  in s).

After the first completed round, she doesn't miss any shots in the shooting round.

After the second completed round, she misses exactly 2 shots in the shooting round.

She completes the 2 penalty rounds with an average speed of  $v_s$  ( $v_s$  in m/s).

The time  $b$  ( $b$  in s) is the time Lisa needs to complete all rounds, including penalty rounds, and the shooting rounds.

1) Using  $v_1$ ,  $v_2$ ,  $v_3$ ,  $t^*$  and  $v_s$ , write down a formula that can be used to calculate  $b$ .

$$b = \underline{\hspace{15em}}$$

[0/1 p.]

b) Hanna's velocity in the first round can be modelled by the function  $v: [0, 440] \rightarrow \mathbb{R}, t \mapsto v(t)$  ( $t$  in s,  $v(t)$  in m/s).

1) Interpret  $\frac{1}{T} \cdot \int_0^T v(t) dt$  with  $T \in (0 \text{ s}, 440 \text{ s}]$  in the given context. [0/1 p.]

There are exactly two times  $t_1, t_2 \in (0 \text{ s}, 440 \text{ s})$  with  $t_1 < t_2$  for which:

$$v'(t_1) = 0 \text{ and } v''(t_1) < 0$$

$$v'(t_2) = 0 \text{ and } v''(t_2) < 0$$

2) Complete the gaps in the following sentence by putting a cross next to one of the given possibilities for each gap so that the sentence becomes a correct statement.

The times  $t_1$  and  $t_2$  are           ①           of the function  $v$ , and the value of  $\frac{v(t_2) - v(t_1)}{t_2 - t_1}$  corresponds to the           ②           in the time interval  $[t_1, t_2]$ . [0/1/2/1 p.]

①	
local minima	<input type="checkbox"/>
local maxima	<input type="checkbox"/>
points of inflexion	<input type="checkbox"/>

②	
average speed	<input type="checkbox"/>
distance covered	<input type="checkbox"/>
average acceleration	<input type="checkbox"/>

c) The random variable  $X$  gives the number of shots Daria shoots successfully and is assumed to be binomially distributed. For each of the 5 shots,  $p$  is the probability of success.

1) Using  $p$ , write down a formula that can be used to calculate the probability shown below.

$P(X \geq 4) =$  \_\_\_\_\_ [0/1 p.]

## Task 27 (Part 2, Best-of Assessment)

### Global Population

The table below shows estimates of the global population (in the middle of each year) for certain years.

year	global population in billions
1850	1.260
1900	1.650
1950	2.536
1960	3.030
1970	3.700
1990	5.327
2000	6.140
2010	6.957
2020	7.790

Data sources: <https://de.statista.com/statistik/daten/studie/1694/umfrage/entwicklung-der-weltbevoelkerungszahl/>,  
[https://www.statistik.at/web\\_de/statistiken/menschen\\_und\\_gesellschaft/bevoelkerung/internationale\\_uebersich/036446.html](https://www.statistik.at/web_de/statistiken/menschen_und_gesellschaft/bevoelkerung/internationale_uebersich/036446.html)  
 [17/05/2020].

#### Task:

- a) In the time period from 1850 to 1950, the global population roughly doubled. Assume that for this time period, the global population increased by the same percentage each year.
- 1) Determine this percentage. [0/1 p.]
- b) From 1970, the development of the global population can be approximated by a linear function  $f$ .
- 1) Using the values for the global population in the years 1970 and 2000, write down an equation of the function  $f$  in terms of the time  $t$  ( $t$  in years with  $t = 0$  for the year 1970,  $f(t)$  in billions). [0/1 p.]
  - 2) Determine the percentage by which the value for 2020 calculated using the function  $f$  differs from the value for 2020 given in the table above. [0/1 p.]

- c) In another model, the development of the global population from 1970 is modelled by the function  $g$ .

$$g(t) = 3.7 \cdot e^{-0.0001 \cdot t^2 + 0.02 \cdot t}$$

$t$  ... time from 1970 in years

$g(t)$  ... global population at time  $t$  in billions

According to this model, the global population will first increase before it begins to decrease.

- 1) Using the function  $g$ , determine the maximum value of the global population and the calendar year in which this value should occur according to the model.

maximum global population: around \_\_\_\_\_ billion

calendar year: \_\_\_\_\_

[0/½/1 p.]

## Task 28 (Part 2, Best-of Assessment)

### Vitamin C

Vitamin C serves many important purposes in a human body.

#### Task:

- a) Broccoli contains on average 100 mg of vitamin C per 100 g.

A random sample of 50 portions of fresh broccoli is selected from a vegetable wholesaler. For each portion, the vitamin C content per 100 g is measured.

The area of a rectangle in the histogram shown below corresponds to the absolute frequency of the portions in this sample in the given region.

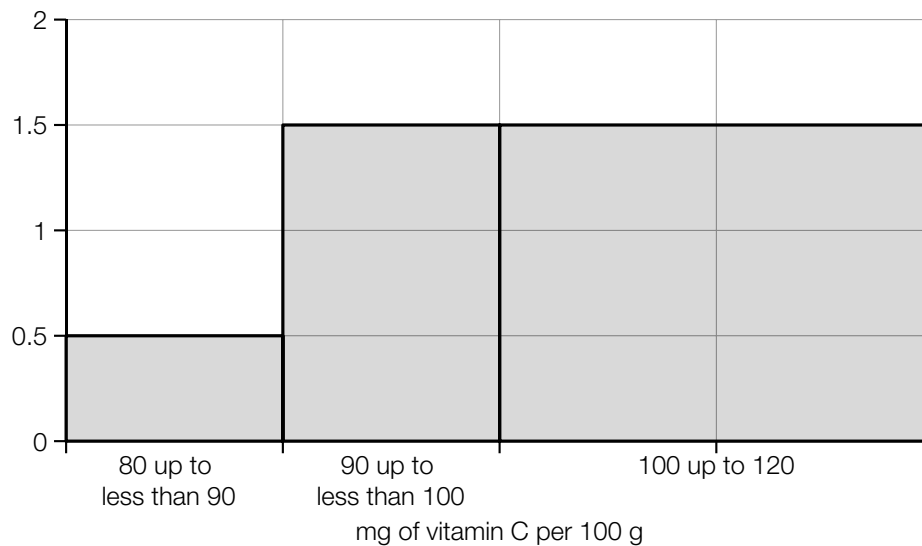

- 1) Determine the number of portions in the random sample that contain 100 mg to 120 mg of vitamin C per 100 g. [0/1 p.]

From the random sample, 3 portions are selected without replacement.

- 2) Determine the probability that at most 2 of these portions contain 100 mg to 120 mg of vitamin C per 100 g. [0/1 p.]



- b) A drinks manufacturer would like to fill bottles with fruit juice so that every bottle contains 100 mg of vitamin C.

The following juices are available:

- pear juice with 20 mg of vitamin C per 100 ml
- orange juice with 35 mg of vitamin C per 100 ml
- mixtures of these two juices

Emine claims that the vitamin C content of 100 mg cannot be reached for bottles that have a capacity of 250 ml.

- 1) Justify why Emine's claim is correct.

*[0/1 p.]*

The available fruit juices are mixed so that 350 ml of juice contains exactly 100 mg of vitamin C.

- 2) Determine the number of millilitres of pear juice and the number of millilitres of orange juice that must be combined to create this mixture.

*[0/1 p.]*

## Task 25 (Part 2)

### Company Logos

Task:

a) The diagram below shows a company logo shaded in grey.

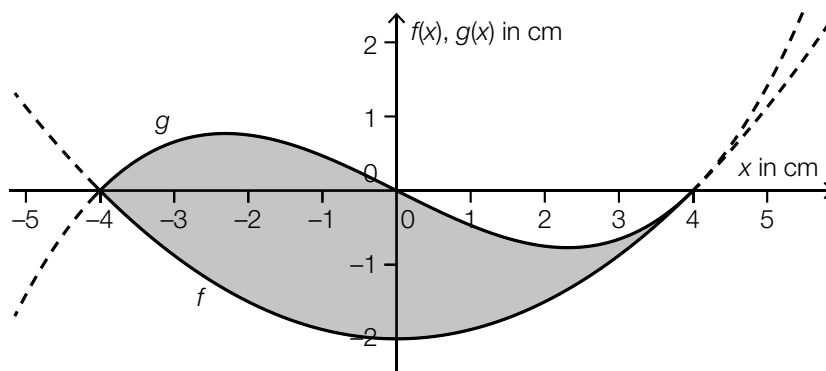

The lower boundary line is defined by a section of the graph of the function  $f$ :

$$f(x) = \frac{1}{8} \cdot x^2 - 2$$

The upper boundary line is defined by a section of the graph of the function  $g$ :

$$g(x) = a \cdot (x^3 - 16 \cdot x) \quad \text{with } a \in \mathbb{R}$$

When  $x = 4$ ,  $f$  and  $g$  have the same gradient.

1) Determine the value of the parameter  $a$ .

[0/1 p.]

The point  $(0, 0)$  is a point of inflexion of the graph of  $g$ .

2) Justify why the graph of the function  $g$  cannot have any further points of inflexion. [0/1 p.]

- b) The logo of a car manufacturer has the shape of a regular pentagon (see the not-to-scale diagram shown below).

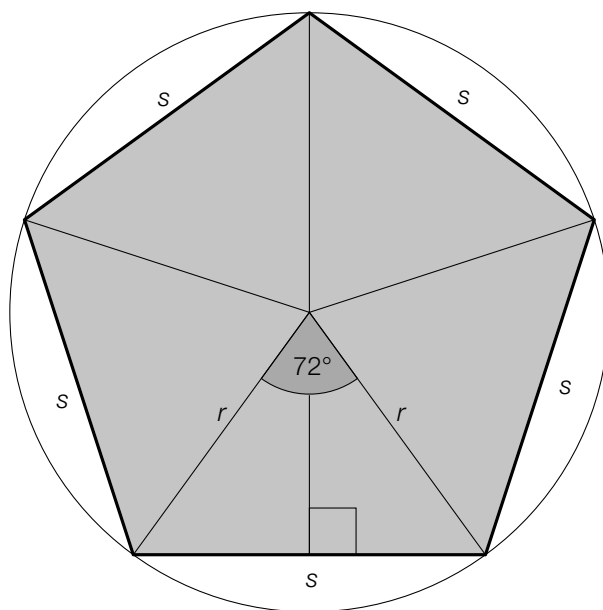

- 1) For  $r = 3$  cm, determine the perimeter  $u$  of this regular pentagon.

[0/1 p.]

- c) The logo for a fish restaurant is shown in grey in the coordinate system below.

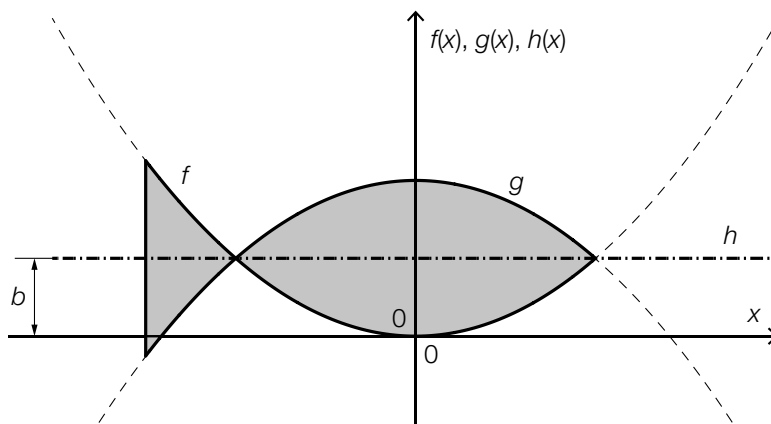

The logo is symmetrical about the graph of the constant function  $h$  with  $h(x) = b$  with  $b \in \mathbb{R}^+$ . The boundary lines of the logo are sections of the graphs of the functions  $f$  and  $g$  (see diagram above).

For the function  $f$ :

$$f(x) = a \cdot x^2 \text{ with } a \in \mathbb{R}^+$$

- 1) Write down an equation of the function  $g$  in terms of  $a$  and  $b$ .

[0/1 p.]

## Task 26 (Part 2, Best-of Assessment)

### Pellet Heating

In households in Austria, various methods of heating are used such as, for example, oil heating (which uses heating oil as fuel) or pellet heating (which uses pellets – small, compacted wood chippings – as fuel).

The table below shows the average annual heating prices for heating oil and pellets for the years 2006 and 2019 in cents per kilowatt-hour (cents/kWh).

	2006	2019
heating oil	6.80	7.95
pellets	4.40	4.84

Data source: <https://www.propellets.at/haeufige-fragen-und-antworten-zu-pellets> [13.10.2021].

#### Task:

- a) 1) Determine the average rate of change of the average annual price for pellets (in cents/kWh per year) for the time period from 2006 to 2019. [0/1 p.]
- b) Family Buchner lives in a house and heats with heating oil. The family is thinking about switching to heating with pellets.  
In order to estimate the total cost of heating with heating oil or with pellets from the year 2019 onwards, the following assumptions are made for family Buchner:
- Family Buchner uses around 15000 kWh of energy per year to heat their house.
  - The average annual price for heating with heating oil (0.0795 €/kWh) and for heating with pellets (0.0484 €/kWh) remain the same from the year 2019 onwards.
  - The transition from oil heating to pellet heating incurs a one-time cost of € 10,000.

$t$  ... time since the start of 2019 in years

$K_{\text{oil}}(t)$  ... estimated total cost of heating with heating oil up to time  $t$  in €

$K_{\text{pellets}}(t)$  ... estimated total cost of heating with pellets up to time  $t$  in €

- 1) Based on these assumptions, write down an equation of a function for each of  $K_{\text{oil}}$  and  $K_{\text{pellets}}$ .

$$K_{\text{oil}}(t) = \underline{\hspace{15em}}$$

$$K_{\text{pellets}}(t) = \underline{\hspace{15em}}$$

[0/½/1 p.]

- 2) Determine the time  $t_1$  at which the estimated total costs for family Buchner for heating with pellets are equal to the estimated total costs for heating with heating oil. [0/1 p.]

- c)\* The number of pellet heating systems in Austria can be modelled by the equation shown below for the time period from 1997 to 2019.

$$A(t) = \frac{147\,130}{1 + 31 \cdot e^{-0.28 \cdot t}}$$

$t$  ... time since the beginning of the year 1997 in years

$A(t)$  ... number of pellet heating systems in Austria at time  $t$

- 1) Determine the year during the time period from 1997 to 2019 when the instantaneous rate of change of the number of pellet heating systems in Austria was greatest according to this model. [0/1 p.]

## Task 27 (Part 2, Best-of Assessment)

### Acceleration Test

For an acceleration test, a vehicle accelerates from rest (initial velocity = 0 km/h).

The diagram below shows the graph of the velocity-time function  $v$  for an acceleration test for a sports car. The sports car moves with velocity  $v(t)$  in km/h  $t$  seconds after it has started accelerating.

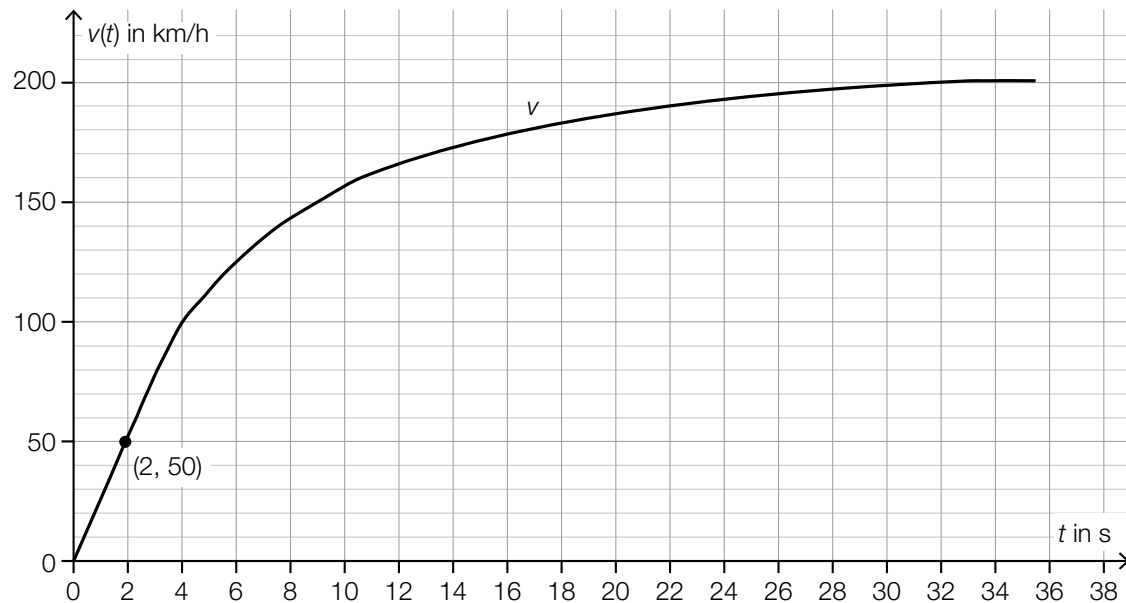

#### Task:

- a) It is assumed that the velocity  $v_1$  of the sports car in the time period  $[0, 2]$  is directly proportional to the time  $t$  ( $t$  in s,  $v_1(t)$  in km/h).

- 1) Write down an equation for the function  $v_1$ .

$$v_1(t) = \underline{\hspace{10em}} \quad [0/1 \text{ p.}]$$

- b) Using another model, the velocity of the sports car in the time period  $[0, 20]$  can be described by the function  $v_2$  in terms of the time  $t$ .

$$v_2(t) = -0.001 \cdot t^4 + 0.078 \cdot t^3 - 2.23 \cdot t^2 + 32 \cdot t$$

$t$  ... time in s

$v_2(t)$  ... velocity at time  $t$  in km/h

- 1) Using  $v_2$ , determine the time  $t_2 \in [0, 20]$  at which the velocity of the sports car is 130 km/h.

[0/1 p.]

- c) The velocity-acceleration function  $a$  assigns each velocity  $v \in [80, 160]$  of the sports car to the approximate corresponding acceleration  $a(v)$ .

$$a(v) = 0.0003 \cdot v^2 + b \cdot v + c \text{ with } b, c \in \mathbb{R}$$

$v$  ... velocity in km/h

$a(v)$  ... acceleration at velocity  $v$  in  $\text{m/s}^2$

The table below shows two values for the acceleration.

$v$ in km/h	80	160
$a(v)$ in $\text{m/s}^2$	6.7	1.4

- 1) Determine  $b$  and  $c$ . *[0/1 p.]*
- 2) Using the function  $a$  and the diagram in the introductory text, determine the time  $t_3$  at which the acceleration is  $3.7 \text{ m/s}^2$ . *[0/1 p.]*

## Task 28 (Part 2, Best-of Assessment)

### Dice Game

In a dice game, five six-sided dice are rolled simultaneously. The numbers 1, 2, 3, 4, 5, and 6 occur on each dice with equal probability. The five dice are rolled independently of each other. The results of the rolls are independent of each other.

Three possible events are described below.

<i>Five-of-a-kind</i>	Any number occurs five times e.g. 4, 4, 4, 4, 4
<i>Full House</i>	Any number occurs exactly three times. Any other number occurs exactly twice e.g. 1, 1, 1, 4, 4
<i>Straight</i>	The numbers 1, 2, 3, 4, 5 or 2, 3, 4, 5, 6 each occur exactly once.

#### Task:

- a) 1) Determine the probability of *Five-of-a-kind* if the five dice are rolled once. [0/1 p.]

The numbers 2, 2, 2, 4 and 5 are rolled. When the player rolls again, only the two dice with the numbers 4 and 5 are rolled again; the other three dice are left on the table.

The probability of *Five-of-a-kind* occurring on this second roll is  $p_1$ .

The probability of a *Full House* occurring on this second roll is  $p_2$ .

- 2) Determine the two probabilities  $p_1$  and  $p_2$ .

$$p_1 = \underline{\hspace{10cm}}$$

$$p_2 = \underline{\hspace{10cm}} \quad [0/1/2/1 p.]$$

- b) The expression below gives the probability of an event  $E$  occurring when the five dice are rolled once:

$$P(E) = 6 \cdot \left[ \binom{5}{4} \cdot \left(\frac{1}{6}\right)^4 \cdot \frac{5}{6} \right]$$

- 1) Describe a possible event  $E$  in the given context. [0/1 p.]



- c) The probability of rolling a *Straight* with the five dice is around 3.09 %.  
The probability of rolling a *Full House* with the five dice is around 3.86 %.

Franz rolls all five dice once. Anna gives Franz 40 euros if he gets a *Straight* or a *Full House*.  
In all other cases, Anna receives  $x$  euros from Franz.

- 1) Determine the value of  $x$  such that the expected amounts that Anna and Franz pay out to each other are approximately equal. [0/1 p.]

## Task 25 (Part 2)

### Sunflowers

Task:

- a) The height of a particular sunflower in terms of the time  $t$  can be approximated by the two quadratic functions  $f$  and  $g$ . The graphs of these two functions have the same gradient at their point  $P$  of intersection (see diagram below).

$$f(t) = \frac{1}{15} \cdot t^2 + 0.2 \cdot t + 5 \quad \text{with } 0 \leq t \leq 21$$

$$g(t) = a \cdot t^2 + b \cdot t + c \quad \text{with } 21 \leq t \leq 42$$

$t \in [0, 42]$  ... time since the start of the observations in days

$f(t)$  ... height of the sunflower at time  $t$  in cm

$g(t)$  ... height of the sunflower at time  $t$  in cm

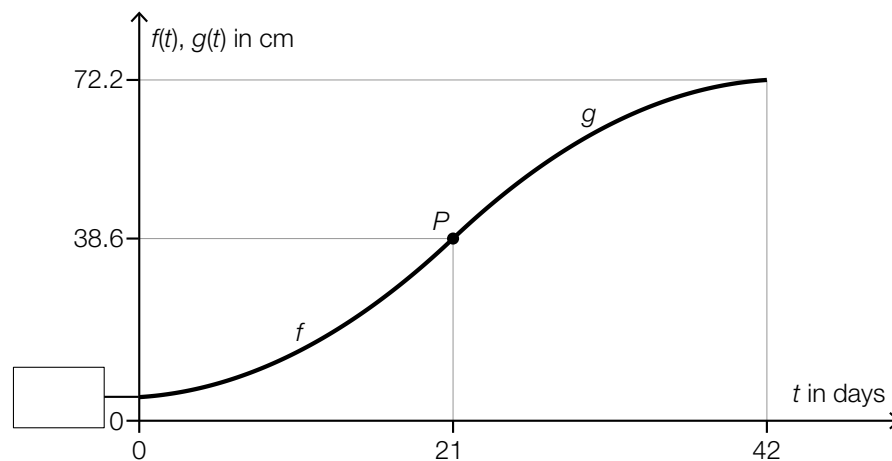

- 1) Complete the missing value on the axis of the diagram above in the box provided. [0/1 p.]
- 2) Write down a system of equations that can be used to calculate the coefficients  $a$ ,  $b$  and  $c$  of the function  $g$ . [0/½/1 p.]
- 3) Interpret the expression below in the given context along with the corresponding unit.

For  $t_1 = 2$  days,  $t_2 = 42$  days:

$$\frac{g(t_2) - f(t_1)}{t_2 - t_1}$$

[0/1 p.]

- b) The height of a different sunflower in terms of the time  $t$  can be approximated over a particular time period by the function  $h$ .

$$h(t) = 6.2 \cdot a^t$$

$t$  ... time since the start of the observations in days

$h(t)$  ... height of the sunflower at time  $t$  in cm

At time  $t = 17$ , the height of this sunflower is 38.6 cm.

- 1) Determine  $a$ .

[0/1 p.]

## Task 26 (Part 2, Best-of Assessment)

### Swimming Course

Task:

- a) During a children's swimming course, a swimming teacher records the distances that each child completes during their first unassisted swim. She determines the following values:

minimum: 1.5 m

median: 3 m

3<sup>rd</sup> quartile: 4 m

range: 5.5 m

interquartile range (difference between the 3<sup>rd</sup> and 1<sup>st</sup> quartiles): 2 m

- 1) Draw the boxplot that corresponds to these values in the space below.

[0/1 p.]

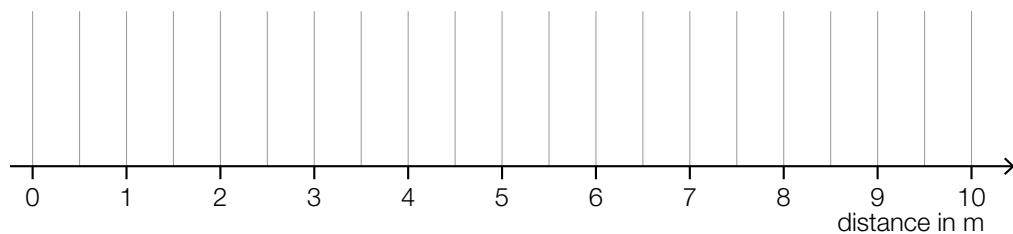

During a different children's swimming course, the distances swum by 17 children were recorded.

The median of these distances swum is 12 m.

Someone claims that 10 children swam a distance less than 12 m.

- 2) Justify why this claim is not correct.

[0/1 p.]

- b) The behaviour of children in a particular swimming group when they first try to jump into the water from the side of the pool can be divided into 3 categories:

	absolute frequency	relative frequency
children that jump in straightaway	20	
children that jump in with hesitation		0.4
children that refuse to jump in	10	

- 1) Complete the 3 missing values in the table above.

[0/1 p.]

- c) In a box, there are 12 red, 10 yellow and 8 blue swim disks. A swimming teacher takes 3 swim disks out of this box one after the other at random and without replacement. (At each stage, each of the remaining swim disks in the box is selected with equal probability.)

The probability of the swimming teacher selecting swim disks in 3 different colours is to be determined.

- 1) Put a cross next to the expression that gives the probability to be determined. [1 out of 6]  
[0/1 p.]

$\frac{12}{30} \cdot \frac{10}{30} \cdot \frac{8}{30}$	<input type="checkbox"/>
$\frac{12}{30} \cdot \frac{10}{30} \cdot \frac{8}{30} \cdot 3$	<input type="checkbox"/>
$\frac{12}{30} \cdot \frac{10}{29} \cdot \frac{8}{28}$	<input type="checkbox"/>
$\frac{12}{30} \cdot \frac{10}{29} \cdot \frac{8}{28} \cdot 3$	<input type="checkbox"/>
$\frac{12}{30} \cdot \frac{10}{29} \cdot \frac{8}{28} \cdot 6$	<input type="checkbox"/>
$\left(\frac{12}{30} \cdot \frac{10}{29} \cdot \frac{8}{28}\right)^3$	<input type="checkbox"/>

## Task 27 (Part 2, Best-of Assessment)

### Special Fourth Degree Polynomial Function

Let  $f$  be a polynomial function with  $f(x) = a \cdot x^4 + b \cdot x^2 + c$  with  $a, b, c \in \mathbb{R} \setminus \{0\}$ .

Task:

- a) 1) Write down an equation in terms of  $a$  and  $b$  that can be used to calculate the point of inflexion of  $f$ . [0/1 p.]
- b) 1) Show by calculation using the 1<sup>st</sup> and 2<sup>nd</sup> derivatives of  $f$  that a maximum or minimum  $P$  of the graph of  $f$  lies on the vertical axis. [0/1 p.]

Exactly one of the coefficients  $a$ ,  $b$  and  $c$  determines whether the point  $P$  is a maximum.

- 2) Complete the gaps in the following sentence by putting a cross next to one of the given possibilities for each gap so that the sentence becomes a correct statement. [0/1 p.]

For the point  $P$  to be a maximum, the coefficient \_\_\_\_\_<sup>①</sup>\_\_\_\_\_ must be \_\_\_\_\_<sup>②</sup>\_\_\_\_\_.

①	
$a$	<input type="checkbox"/>
$b$	<input type="checkbox"/>
$c$	<input type="checkbox"/>

②	
less than 0	<input type="checkbox"/>
equal to 1	<input type="checkbox"/>
greater than 0	<input type="checkbox"/>

- c) Let  $g$  be a polynomial function with  $g(x) = d \cdot (x + e)^2 \cdot (x - e)^2$  with  $d \neq 0$  and  $e \in \mathbb{R}$ . The graph of  $g$  goes through the point  $N = (2, 0)$ .

- 1) Under these conditions, determine all possible values of  $e$ . [0/1 p.]

## Task 28 (Part 2, Best-of Assessment)

### Braking

Braking causes a negative acceleration, which reduces the velocity of a moving vehicle.

#### Task:

- a) A particular vehicle is brought to a complete stop through braking. The distance covered by the vehicle while braking is known as the *braking distance*.

The diagram below shows the velocity-time diagram for a vehicle that comes to a complete stop through braking in 5 s.

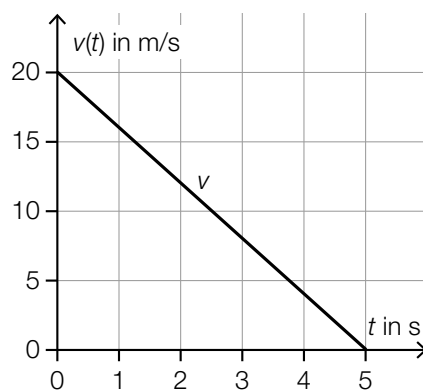

The following conditions hold for the velocity-time function  $v$ :

$$v(t) = -4 \cdot t + 20 \quad \text{with } t \in [0, 5]$$

$t$  ... time in s

$v(t)$  ... velocity at time  $t$  in m/s

- 1) Interpret the coefficients  $-4$  and  $20$  in the equation of the function shown above in the given context. [0/½/1 p.]

The length of the braking distance of this vehicle until it comes to a complete stop is given by  $s_B$ . If the initial velocity is halved and the negative acceleration remains the same, then the length of the braking distance reduces to  $k \cdot s_B$  with  $k \in \mathbb{R}$ .

- 2) Determine  $k$ . [0/1 p.]

- b) A vehicle travels with a constant velocity of 25 m/s. At time  $t = 0$ , the driver sees an obstacle on the road.

The following conditions hold:

- The driver requires a certain amount of time to react. During this time, the vehicle continues to travel at a constant velocity of 25 m/s.
- The driver begins to brake at time  $t_1$  with a constant deceleration due to braking (negative acceleration).
- At time  $t_2$ , the vehicle comes to a complete stop.

- 1) On the velocity-time diagram below, draw the corresponding velocity-time graph for the situation described above ( $t$  in s,  $v_1(t)$  in m/s). [0/1 p.]

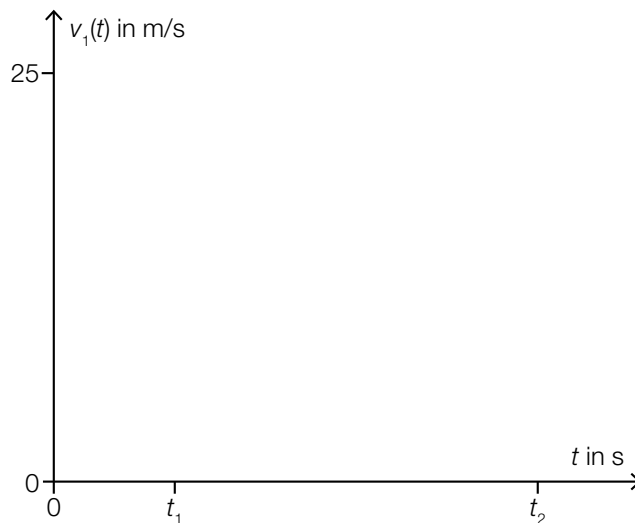

The distance covered by the vehicle in the time interval  $[0, t_2]$  is known as the *stopping distance*  $s_A$  ( $s_A$  in m).

- 2) Write down a formula that can be used to calculate  $s_A$  in terms of  $t_1$  and  $t_2$ .

$s_A =$  \_\_\_\_\_

[0/1 p.]



## Task 25 (Part 2)

### Caffeine

Task:

- a) Lea drinks a cup of coffee. The diagram below shows the graph of the function  $K$ , which models the concentration  $K(t)$  of caffeine in Lea's blood in terms of the time  $t$  after Lea drinks the coffee ( $t$  in h,  $K(t)$  in mg/L).

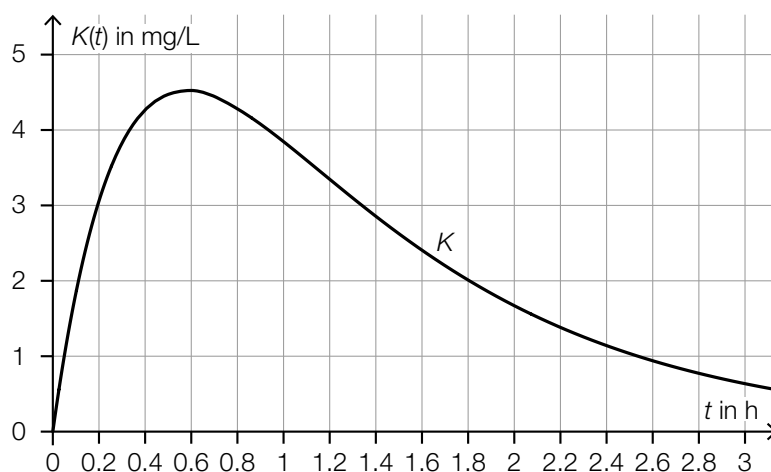

- 1) Using the diagram above, determine the time in minutes after drinking the coffee at which the concentration of caffeine in the blood is at a maximum.

\_\_\_\_\_ min

[0/1 p.]

- 2) Complete the gaps in the following sentence by putting a cross next to one of the given possibilities for each gap so that the sentence becomes a correct statement. [0/1/2/1 p.]

The function  $K$  has \_\_\_\_\_ ① \_\_\_\_\_ in the interval  $(0, 0.8)$  and in this interval the sign of the \_\_\_\_\_ ② \_\_\_\_\_ changes.

①	
a point of inflexion	<input type="checkbox"/>
a maximum or minimum	<input type="checkbox"/>
a zero	<input type="checkbox"/>

②	
concavity	<input type="checkbox"/>
gradient	<input type="checkbox"/>
values of the function	<input type="checkbox"/>

- b) The solubility of caffeine in water gives the maximum number of grams of caffeine per litre (g/L) that can be dissolved. The solubility is dependent on the temperature. It can be approximated by the function  $f$ .

$$f(T) = 6.42 \cdot e^{0.05 \cdot T} \quad \text{with} \quad 0 \leq T \leq 90$$

$T$  ... temperature in °C

$f(T)$  ... solubility of caffeine in water at the temperature  $T$  in g/L

A person claims:

“If the temperature increases by 10 °C, then the solubility of caffeine in water increases by around 1.65 times.”

- 1) Verify by calculation whether the claim is true. [0/1 p.]

The following equation is formed:

$$2 \cdot 6.42 = 6.42 \cdot e^{0.05 \cdot T}$$

- 2) Interpret the solution to this equation in the given context. [0/1 p.]

## Task 26 (Part 2, Best-of Assessment)

### CO<sub>2</sub> and Climate Protection

In recent decades, the CO<sub>2</sub> concentration of the Earth's atmosphere has increased due to vehicle traffic, among other factors.

Task:

- a) For each car that runs on petrol, it is assumed that 2.32 kg of CO<sub>2</sub> is emitted per litre of petrol used.

Car *A* travels a distance of  $s$  km with an average petrol consumption of 7.9 litres per 100 km.

In order to offset these CO<sub>2</sub> emissions,  $b$  trees are to be planted. It is assumed that each of these trees captures 500 kg of CO<sub>2</sub> over its whole lifetime.

- 1) Write down the number  $b$  of trees to be planted in terms of  $s$ .

$b =$  \_\_\_\_\_ [0/1 p.]

Car *B* travels a distance of 15000 km. In order to offset these CO<sub>2</sub> emissions, 5 trees are planted.

- 2) Determine the average petrol consumption (in litres per 100 km) of car *B* on this journey.

[0/1 p.]

- b) Alongside CO<sub>2</sub>, other gases also contribute to global warming. The emissions of these gases are converted into a so-called CO<sub>2</sub> equivalent.

The table below shows information about the population (in millions) for some EU countries in the year 2015 and the corresponding CO<sub>2</sub> equivalents (in tonnes per person).

	population in millions	CO <sub>2</sub> equivalent in tonnes per person
Belgium	11.2	11.9
France	66.4	6.8
Italy	60.8	7.0
Luxembourg	0.6	18.5
The Netherlands	16.9	12.3

Data sources: [https://ec.europa.eu/eurostat/statistics-explained/index.php?title=Population\\_and\\_population\\_change\\_statistics/de&oldid=320539](https://ec.europa.eu/eurostat/statistics-explained/index.php?title=Population_and_population_change_statistics/de&oldid=320539) [24.07.2020],  
[https://de.wikipedia.org/wiki/Liste\\_der\\_Länder\\_nach\\_Treibhausgas-Emissionen](https://de.wikipedia.org/wiki/Liste_der_Länder_nach_Treibhausgas-Emissionen) [24.07.2020].

- 1) Determine the average CO<sub>2</sub> equivalent  $\bar{e}$  (in tonnes per person) for the whole of the part of the EU represented in the table above.

$\bar{e} =$  \_\_\_\_\_ tonnes per person [0/1 p.]

Lukas is only aware of the values for the CO<sub>2</sub> equivalents for the individual countries given in the table above but not the corresponding population values. He calculates the mean  $\bar{x}$  of the CO<sub>2</sub> equivalents:  $\bar{x} = 11.3$ .

- 2) Without using the value of  $\bar{e}$  calculated above, explain why  $\bar{x}$  must be greater than  $\bar{e}$ .

[0/1 p.]

## Task 27 (Part 2, Best-of Assessment)

### Velocity-Time Graph

The velocities of 2 cars (car A and car B) are modelled as functions in terms of time. The velocity-time graph shown below shows the corresponding graphs. The time  $t$  is given in seconds and the velocities are given in m/s.

Car A and car B set off from standing at time  $t = 0$ . They both have a velocity of 12 m/s at time  $t = 10$ .

Car A moves for  $t \in [0, 6]$  at a velocity of  $v_1(t)$  and for  $t \in [6, 10]$  at a constant velocity of  $v_2(t)$ .

Car B moves for  $t \in [0, 10]$  at a velocity of  $v_3(t) = 0.12 \cdot t^2$ .

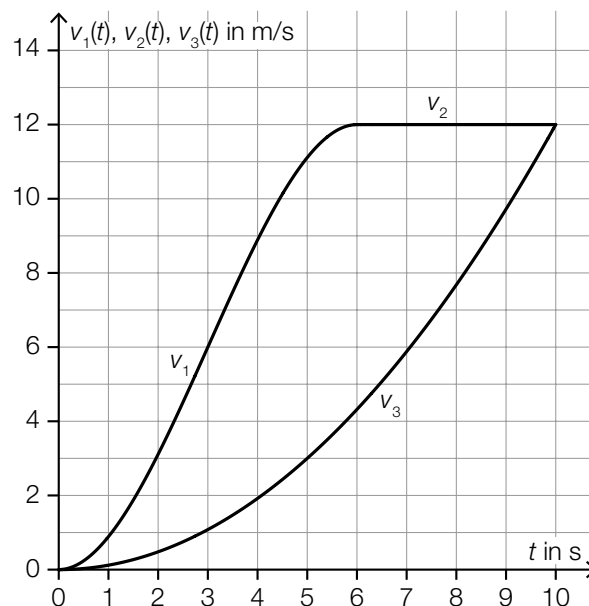

Task:

- a) In the time interval  $[0, 6]$ , car A covers a distance of 36 m.  
 In the time interval  $[0, t_1]$  with  $6 \leq t_1 \leq 10$ , car A covers a distance of length  $d$  ( $d$  in m).

1) Write  $d$  in terms of  $t_1$ .

$$d = \underline{\hspace{10cm}}$$

[0/1 p.]

In the time interval  $[0, 10]$  car A covers a longer distance than car B.

2) Determine the length in metres by which this distance is longer.

[0/1 p.]

b) For car  $A$  the following conditions hold:

- At time  $t = 6$ , the velocity is 12 m/s.
- At time  $t = 0$ , the acceleration is 0 m/s<sup>2</sup>.
- At time  $t = 3$ , the acceleration is at its maximum value.

The following statement holds for the function  $v_1: [0, 6] \rightarrow \mathbb{R}$ :

$$v_1(t) = p \cdot t^3 + q \cdot t^2 + r \cdot t \text{ for all } t \in [0, 6] \text{ with } p, q, r \in \mathbb{R}$$

- 1) Write down a system of 3 equations with which the coefficients  $p$ ,  $q$  and  $r$  can be calculated. [0/1/2/1 p.]

c) The acceleration of car  $B$  in the time interval  $[0, 10]$  is described in terms of the time  $t$  by the function  $a_3$  ( $t$  in s,  $a_3(t)$  in m/s<sup>2</sup>).

- 1) In the coordinate system given below, draw the graph of the acceleration function  $a_3$ . [0/1 p.]

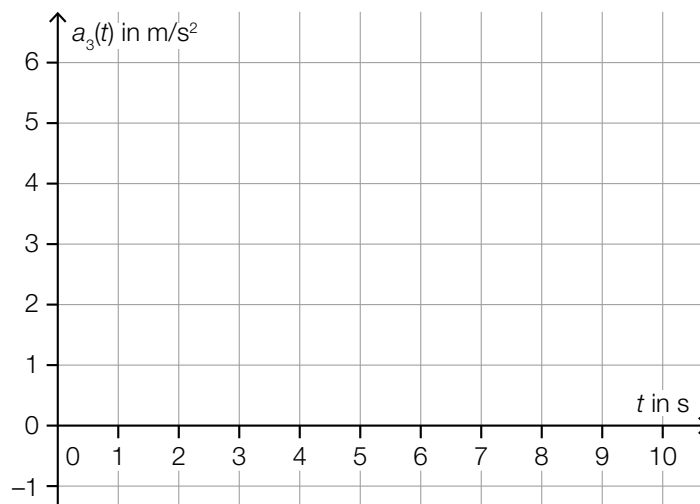

## Task 28 (Part 2, Best-of Assessment)

### Dice Game

In a dice game, different dice, each with 6 faces, are used. For all of the dice used, the probability of any of the faces occurring is the same for all faces. The results of each throw are independent of each other.

Three types of dice,  $A$ ,  $B$  and  $C$ , are used. The faces of these dice are shown in the diagram below.

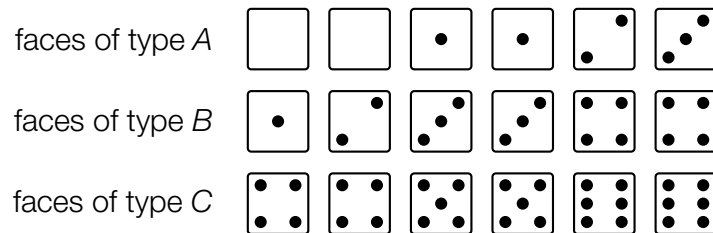

Task:

a) A player throws one type  $B$  dice and one type  $C$  dice simultaneously one time.

1) Determine the probability that the sum of the numbers shown on the faces is 8. [0/1 p.]

b) The random variables  $X_A$ ,  $X_B$  and  $X_C$  give the number that occurs after being thrown for a type  $A$  dice, a type  $B$  dice and a type  $C$  dice respectively. One of these three random variables has an integer expectation value.

1) Write down this integer expectation value. [0/1 p.]

Both of the other random variables have the same standard deviation.

2) Determine this standard deviation. [0/1 p.]

c) A type  $C$  dice is thrown  $n$  times. The random variable  $Y_n$  gives the number of throws for which an odd number is shown on the face in these  $n$  throws ( $n \in \mathbb{N}$ ). The expectation value of  $Y_n$  is given by  $\mu_n$  and the standard deviation is given by  $\sigma_n$ .

1) Write down  $\mu_n$  and  $\sigma_n$  in terms of  $n$ .

$$\mu_n = \underline{\hspace{10cm}}$$

$$\sigma_n = \underline{\hspace{10cm}}$$

[0/½/1 p.]

## Task 25 (Part 2)

### Prom

#### Task:

- a) Tickets for a prom can be bought in advance or on the door. In advance, each ticket costs € 20. On the door, each ticket costs 10 % more.

Overall, 640 tickets were sold for a total price of € 13240.

The following notation has been chosen:

$x$  ... the number of tickets sold in advance

$y$  ... the number of tickets sold on the door

- 1) Write down a system of equations that can be used to calculate  $x$  and  $y$ . [0/1½/1 p.]

- b) For entertainment, a *wheel of fortune* game is to be offered. The probability of winning is constant for each game at 25 %, independent of the other games played.

Katja plays this game 3 times.

- 1) Determine the probability that Katja wins exactly 2 times. [0/1 p.]

- c) The game *hook-a-duck* is also to be offered.  
From a total of 50 rubber ducks, 5 are marked underneath.

In this game, a participant chooses 2 of the 50 rubber ducks at random and without replacement. Each marked rubber duck that has been chosen results in a prize.

The random variable  $X$  describes how many of the two chosen rubber ducks are marked. The probability of one possible event in this context can be calculated with the following expression.

$$P(X = \boxed{\phantom{00}}) = \frac{5}{50} \cdot \frac{45}{49} + \frac{45}{50} \cdot \frac{5}{49}$$

- 1) Write down the missing number in the box provided. [0/1 p.]

Martin claims: "The random variable  $X$  is binomially distributed."

- 2) Justify why Martin's claim is false. [0/1 p.]



## Task 26 (Part 2, Best-of Assessment)

### Changes in Temperature

The process of the cooling or heating up of a drink can be modelled by functions. For these functions, the temperature of the drink in °C can be given in terms of the time  $t$  in minutes.

Task:

- a) Tea cooling in a teapot can be described by the function  $g$  with  $g(t) = 70 \cdot e^{-0.045 \cdot t} + 18$ .

At time  $t^*$  the temperature of the tea has cooled to 37 °C.

- 1) Determine  $t^*$ .

$$t^* = \underline{\hspace{10em}} \text{ min} \quad [0/1 \text{ p.}]$$

- 2) Determine the average rate of change of  $g$  in the interval [10 min, 12 min]. Interpret the result along with the corresponding unit in the given context. [0/½/1 p.]

- b) A particular cooled wine in a wine glass has an initial temperature of  $T_0 = 5$  °C. The ambient temperature is a constant  $U = 25$  °C.

The temperature of the wine is measured at regular intervals. At time  $t$  it has a value  $T_t$ .

Each minute, the temperature of the wine increases by 8 % of the difference between the ambient temperature  $U$  and the temperature  $T_t$  of the wine measured at time  $t$ . The temperature of the wine thus rises to the value  $T_{t+1}$ .

- 1) Complete the following difference equation for this heating process.

$$T_{t+1} = T_t + \underline{\hspace{10em}} \quad \text{with } T_0 = 5 \quad [0/1 \text{ p.}]$$

- 2) Determine the temperature of the wine at the time  $t = 3$  min. [0/1 p.]

## Task 27 (Part 2, Best-of Assessment)

### Satellites and Their Orbits

A satellite moves along an approximately circular orbit with a radius of  $r$  around the earth. The earth is assumed to be spherical with radius  $R$ .

This model is represented in the diagram below.

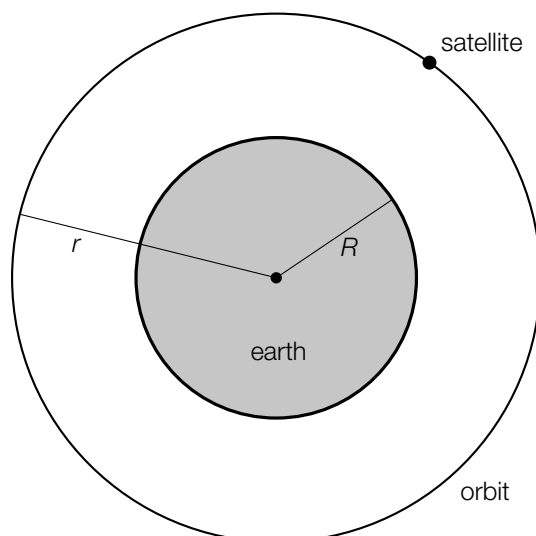

#### Task:

- a) A particular satellite moves with a velocity of  $v = 7\,500$  m/s along its orbit. The relationship between its velocity and the radius of its orbit is given by the equation below.

$$v = \sqrt{\frac{G \cdot M}{r}}$$

$v$  ... velocity of the satellite in m/s

$G = 6.67 \cdot 10^{-11}$  ... universal gravitational constant in  $\frac{\text{m}^3}{\text{kg} \cdot \text{s}^2}$

$M = 5.97 \cdot 10^{24}$  ... mass of the earth in kg

$r$  ... radius of the orbit of the satellite in m

- 1) Determine the radius  $r$  of the orbit of this satellite.

$$r = \underline{\hspace{10cm}} \text{ m} \quad [0/1 \text{ p.}]$$

- 2) Determine the time (in s) that this satellite takes to complete one orbit of the earth.

$$t = \underline{\hspace{10cm}} \text{ s} \quad [0/1 \text{ p.}]$$

- b) The satellite dish of a research station is aligned with a particular satellite.

The following not-to-scale diagram represents this situation.

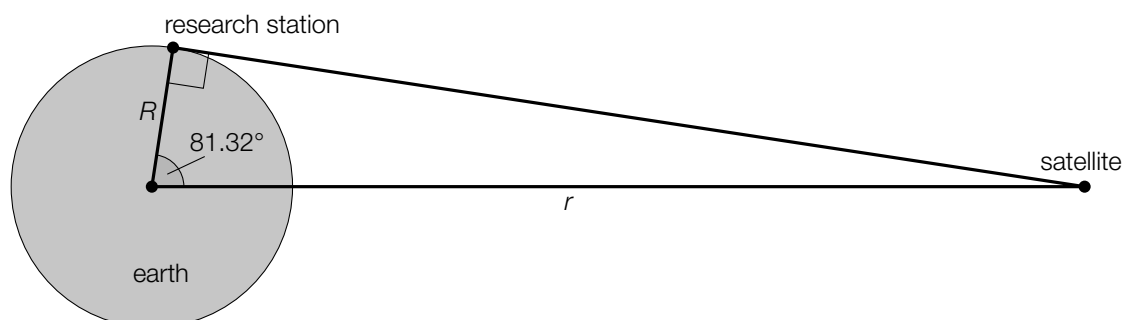

The earth's radius  $R$  is assumed to be  $R = 6.37 \cdot 10^6$  m.

- 1) Determine the radius  $r$  of the orbit of this satellite.

$r =$  \_\_\_\_\_ m [0/1 p.]

The velocity of radio signals is assumed to be  $3 \cdot 10^8$  m/s.

- 2) Determine the time (in s) required for a radio signal to travel from the research station to this satellite. Write the solution correct to 3 decimal places. [0/1 p.]

## Task 28 (Part 2, Best-of Assessment)

### Storage Media

In recent decades, various storage media, such as memory cards, USB sticks or DVDs have been used to back up data.

Task:

- a) The storage capacity of a storage medium can be given in kilobytes, megabytes or gigabytes, for example. The prefixes *kilo-*, *mega-*, *giga-* are used as follows:

1 megabyte = 1 024 kilobytes

1 gigabyte = 1 024 megabytes

A particular memory card with a capacity of 16 gigabytes is used to store photos. For the purpose of the model, it is assumed that all of the photos require the same amount of memory.

The function  $N: \mathbb{R}^+ \rightarrow \mathbb{R}^+$  assigns the required memory  $F$  for one photo to the largest possible number  $N(F)$  of photos that can be stored on this memory card ( $F$  in kilobytes).

- 1) Write down an equation of the function  $N$ .

$N(F) =$  \_\_\_\_\_ [0/1 p.]

- b) Michael has 4 USB sticks labelled  $A$ ,  $B$ ,  $C$  and  $D$ .

- On USB stick  $A$ , he saves all of his photos.
- On the 3 other USB sticks,  $B$ ,  $C$  and  $D$ , he saves exactly one third of all of his photos so that every photo is also stored on exactly 1 of these 3 USB sticks as a backup.

For each of the 4 USB sticks, the probability that it still works after 5 years is 75 % (independent of the other sticks).

As a simplification, it can be assumed that a USB stick either works fully or does not work at all.

- 1) Determine the probability that after 5 years every one of Michael's photos is still available on at least 1 USB stick. [0/1 p.]

After 5 years, Michael realises that USB stick  $A$  no longer works.

- 2) Determine the probability that at least 2 of the 3 USB sticks  $B$ ,  $C$  and  $D$  still work. [0/1 p.]

c) A popular storage medium for films is the DVD.

Since the beginning of the 21st century, the average price of a film DVD has decreased, as shown in the diagram below.

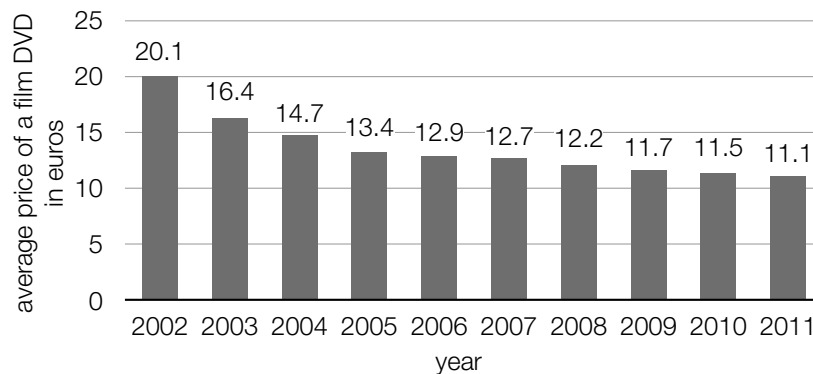

Data source: <https://www.mkdiscpress.de/ratgeber/chronik-der-speichermedien/> [20.11.2019].

The average price of a film DVD is modelled by the function  $P$  in terms of the time  $t$ .

$$P(t) = a \cdot b^t + 11 \quad \text{with } a, b \in \mathbb{R}^+$$

$t$  ... time in years with  $t = 0$  for the year 2002

$P(t)$  ... average price of a film DVD at time  $t$  in euros

1) Determine  $a$  and  $b$  such that  $P$  for the years 2002 and 2011 corresponds to the average price of a film DVD in the respective year according to the diagram above.

$a =$  \_\_\_\_\_

$b =$  \_\_\_\_\_

[0/½/1 p.]

## Task 25 (Part 2)

### Sick Leave

The average duration of sick leave for employees in a particular company has decreased in recent years.

Task:

- a) The table below shows the average duration of sick leave in days for the year 2000 and for the year 2015.

year	average duration of sick leave in days
2000	12.6
2015	9.9

A linear function  $K$  that gives the average duration of sick leave in terms of the time  $t$  from the year 2000 is to be created based on this data.

- 1) Write down an equation of the linear function  $K$ .

[0/1 p.]

$$K(t) = \underline{\hspace{10cm}}$$

$t$  ... time in years with  $t = 0$  for the year 2000

$K(t)$  ... average duration of sick leave at time  $t$  in days

The following calculation is carried out:

$$\frac{9.9 - 12.6}{12.6} \approx -0.214$$

- 2) Interpret the result of this calculation in the given context.

[0/1 p.]

- b) From many years of experience it is known that employee  $A$  has a probability of being unwell in winter of 20 % and employee  $B$  has a probability of being unwell in winter of 30 %.

It is assumed that all illnesses are independent of each other.

- 1) Write down a possible event  $E$  in the given context whose probability can be calculated with the expression shown below.

$$P(E) = 1 - 0.8 \cdot 0.7$$

[0/1 p.]

- 2) Determine the probability that employee  $A$  is unwell in at most 1 out of 5 winters.

[0/1 p.]

## Task 26 (Part 2, Best-of Assessment)

### Hurricanes and Tropical Cyclones

The *Saffir-Simpson Hurricane Scale* classifies hurricanes according to their wind speed into five categories, from Category 1 (weak) to Category 5 (devastating).

#### Task:

- a) Different levels of potential damage that describe the damage caused are associated with the individual hurricane categories on this scale:

hurricane category	1	2	3	4	5
level of potential damage	1	10	50	250	500

Data source: Pielke Jr., Roger A. und Christopher W. Landsea: Normalized Hurricane Damages in the United States: 1925–95. In: *Weather and Forecasting* 13(3) (1998), p. 621–631.

- 1) Using values from the table, show that the relationship between the hurricane category and the level of potential damage is not linear and is also not exponential. [0/½/1 p.]

- b) In the 45 year period from 1972 to 2016, 100 *intense hurricanes* (these are hurricanes that fall into one of the categories 3, 4 and 5 on the Saffir-Simpson Hurricane Scale) occurred.

The number of all hurricanes per year in the time period from 1972 to 2016 is investigated.

$\bar{x}$  ... mean of the number of all hurricanes per year

$h$  ... relative frequency of intense hurricanes out of the total number of all hurricanes from 1972 to 2016.

- 1) Write down a formula in terms of  $\bar{x}$  that can be used to determine  $h$ .

$$h = \underline{\hspace{10cm}}$$

[0/1 p.]

The table below gives an overview of the number of all hurricanes per year for the time period from 1972 to 2016.

number of hurricanes per year	number of years
0 to 2	2
3 to 5	20
6 to 8	14
9 to 11	7
12 to 14	1
15 to 17	1

Data source: Landsea, Christopher W., Gabriel A. Vecchi et al.: Impact of Duration Thresholds on Atlantic Tropical Cyclone Counts. In: *Journal of Climate* 23(10) (2010), p. 2508–2519.

An exact calculation of the mean  $\bar{x}$  of the number of all hurricanes per year is not possible given the data in the table above. However, an estimate of  $\bar{x}$  can be determined by taking the midpoint of the class intervals given in the left-hand column. For example, the value 10 is the midpoint of “9 to 11”.

- 2) Determine this estimate of  $\bar{x}$ .

$$\text{estimate of } \bar{x}: \underline{\hspace{10cm}}$$

[0/1 p.]

- c) Wind speeds are often given in kilometers per hour (km/h) or knots (kn) whereby  
 $1 \text{ kn} = 1.852 \text{ km/h}$ .

There is a directly proportional relationship between the wind speed  $v$  (in km/h) and the wind speed  $v_k$  (in kn).

- 1) Write down an equation that describes this relationship.

[0/1 p.]



## Task 27 (Part 2, Best-of Assessment)

### Occupancy of Flights

It is important for flight operators that their flights operate with high occupancy rates.

#### Task:

- a) It is common that not all tickets sold for flights are used. Therefore, more tickets are usually sold for a flight than the available number of seats on the plane.  
The probability that a passenger (independent of the other passengers) uses their ticket to fly is 90 %.

For a particular flight, 6 % more tickets are sold than the available number of seats on the plane.

There are  $m$  seats available on the plane.

$n$  tickets are sold.

For  $n$  tickets sold, the expectation value for the number of tickets used to fly is 477.

- 1) Determine  $n$  and  $m$ .

$$n = \underline{\hspace{10cm}}$$

$$m = \underline{\hspace{10cm}} \quad [0/1 p.]$$

The following event  $E$  is considered:

$E$  ... "for at least 1 passenger who wants to use their ticket to fly, there is no seat available on the plane"

- 2) Determine the probability  $P(E)$ . [0/1 p.]

- b) For a particular flight of a fully occupied plane, the relationship between the flight distance  $s$  and the fuel consumption  $V(s)$  can be modelled by the function  $V: [2000, 10000] \rightarrow \mathbb{R}^+$ .

$$V(s) = 4 + \left( \frac{s}{128000} - \frac{1}{4} \right) \cdot \frac{s}{1000} \cdot e^{-\frac{s}{4000}} \quad \text{with } 2000 \leq s \leq 10000$$

$s$  ... flight distance in km

$V(s)$  ... fuel consumption for a flight distance  $s$  in litres per passenger per 100 km

- 1) Determine the flight distance  $d$  (in km) for which the fuel consumption is lowest. [0/1 p.]  
2) Determine the amount of fuel (in l) that this plane requires for the flight distance  $d$  if it is fully occupied with 271 passengers. [0/1 p.]

## Task 28 (Part 2, Best-of Assessment)

### Respiratory Flow

The *respiratory flow* is the amount of air breathed in or out per time period. It is modelled by the function  $f$  in terms of the time  $t$  ( $t$  in s,  $f(t)$  in l/s).

The respiratory flow for Mathias can be modelled by:

$$f(t) = 0.5 \cdot \sin(1.25 \cdot t)$$

One breath cycle comprises one complete breath in and one complete breath out. The recording starts at time  $t = 0$ .

One breath cycle is shown in the diagram below.

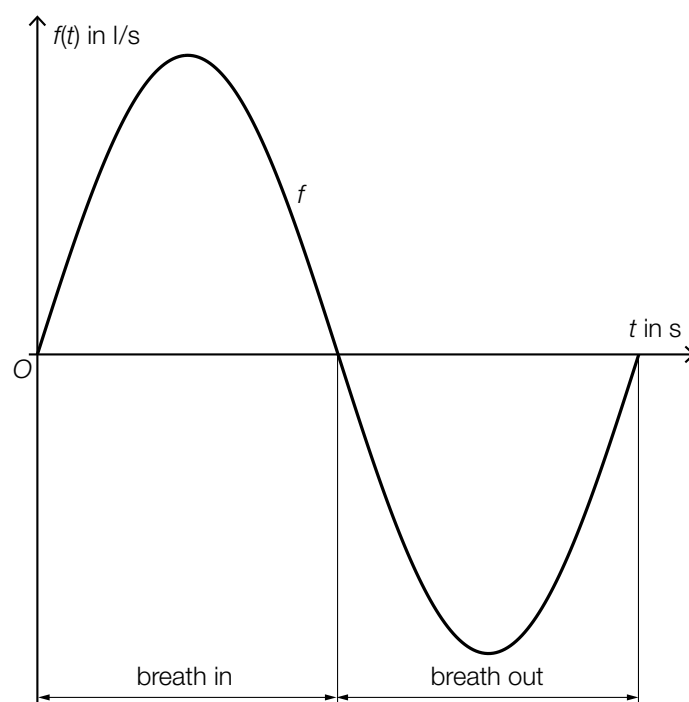

Task:

a) When Mathias breathes out, the function  $f$  has a minimum at  $t_1$ .

1) Determine  $t_1$  (in s).

$$t_1 = \underline{\hspace{10cm}} \text{ s}$$

[0/1 p.]

In the breath cycle shown above, the time  $t_2$  with  $t_2 > 0$  corresponds to the point in time when the volume of air in Mathias's lungs is at a minimum for the first time since the beginning of the breath cycle.

2) Determine  $t_2$  (in s).

$$t_2 = \underline{\hspace{10cm}} \text{ s}$$

[0/1 p.]

b) At the beginning of a breath in, there are 3.5 litres of air in Mathias's lungs.

1) Interpret the calculation shown below in the given context.

$$\int_0^{2.5} f(t) dt + 3.5 \approx 4.29$$

[0/1 p.]

The function  $V$  describes the volume  $V(t)$  of air breathed in by Mathias during one breath in in terms of the time  $t$  (the beginning of the breath in is at  $t = 0$  and  $V(0) = 0$ ,  $t$  in s,  $V(t)$  in l).

2) Write down the two missing numbers in the equation of the function  $V$  shown below.

$$V(t) = -0.4 \cdot \cos(\underline{\hspace{2cm}} \cdot t) + \underline{\hspace{2cm}}$$

[0/½/1 p.]

## Task 25 (Part 2)

### Parachute Jump

During a parachute jump from a height of 4 000 m above the ground, the parachute is opened 30 s after jumping off.

The function  $v_1$  with  $v_1(t) = 56 - 56 \cdot e^{-\frac{t}{4}}$  for  $t \in [0, 30]$  (whilst considering air resistance) describes the speed of the fall of the parachutist at the time  $t$  ( $t$  in s after jumping off,  $v_1(t)$  in m/s).

The function  $v_2$  with  $v_2(t) = \frac{51}{(t-29)^2} + 5 - 56 \cdot e^{-7.5}$  for  $t \geq 30$  describes the speed of the fall of the parachutist at the time  $t$  until the time of landing ( $t$  in s after jumping off,  $v_2(t)$  in m/s).

It can be assumed that the parachute jump is vertical.

#### Task:

a) 1)  Interpret  $w = \frac{v_1(10) - v_1(5)}{10 - 5}$  in the given context.

For a  $t_1 \in [0, 30]$   $v_1'(t_1) = w$  holds.

2) Interpret  $t_1$  in the given context.

b) 1) Using the function  $v_1$ , calculate at which height the parachute is opened.

2) Calculate the amount of time taken for the entire parachute jump, from jumping off to landing.

c) Without considering air resistance, the parachutist would have an initial speed of 0 m/s and a constant acceleration of  $9.81 \text{ m/s}^2$  during the time interval  $[0, 30]$ . The speed of the fall 9 s after jumping off would be  $v^*$ .

1) Calculate how much smaller  $v_1(9)$  is than  $v^*$ .

2) Calculate by how many percent the acceleration of the parachutist is lower than during a jump which does not consider the air resistance 9 s after jumping off.

## Task 26 (Part 2)

### Growth Processes

Below, models of growth are considered.

The following difference equation describes a growth process.

$$N_{t+1} - N_t = r \cdot (S - N_t)$$

$N_t$  ... population at time  $t$

$r$  ... growth constant,  $r \in \mathbb{R}^+$

$S$  ... (upper) capacity limit

#### Task:

- a) On a cruise ship with 2000 passengers, of which none are sick at the time  $t = 0$  days, 5 % of the healthy people get sick every day.  $N_t$  gives the number of sick passengers at the time  $t$  (with  $t$  in days).

1) Write down a difference equation for  $N_{t+1}$ .

2) Determine after how many days more than 25 % of the passengers are sick for the first time.

- b) The difference equation  $N_{t+1} - N_t = r \cdot (S - N_t)$  can also be written as  $N_{t+1} = a \cdot N_t + b$  with  $a, b \in \mathbb{R}$ .

1) Write  $r$  and  $S$  in terms of  $a$  and  $b$ .

$$r = \underline{\hspace{10cm}}$$

$$S = \underline{\hspace{10cm}}$$

The growth of a bacterial culture in a petri dish is observed in order to develop a new vaccine.

The following table shows the area  $N_t$  (in  $\text{cm}^2$ ) that is covered by the bacteria culture at the time  $t$  (in h).

$t$ in h	$N_t$ in $\text{cm}^2$
0	5.00
1	9.80
2	14.41

2) Determine  $a$  and  $b$  using the values from the table above.

- c) A pharmaceutical company is launching a new vaccine on the market. In the first week after the launch, 15 000 people have already purchased the vaccine.

The number  $f(t)$  of people who have purchased the vaccine within  $t$  weeks after the launch can be modelled by the function  $f$  with  $f(t) = 1\,000\,000 \cdot (1 - e^{-k \cdot t})$  ( $k \in \mathbb{R}^+$ ).

- 1)  A Calculate  $k$ .
- 2) Determine the earliest point in time  $t_0$  at which more than 500 000 people have purchased this vaccine.

## Task 27 (Part 2)

### Quiz with a Game Board

During a quiz, a series of questions, which can each be answered with “yes” or “no”, are asked. On a game board, a token is placed on the field with the number 0 at the beginning of each game. The token moves one field to the right for every correct answer given and one field to the left for every incorrect answer given. Each field is labelled with an integer value in ascending order (see the illustration below). The game board can be extended freely in any direction.

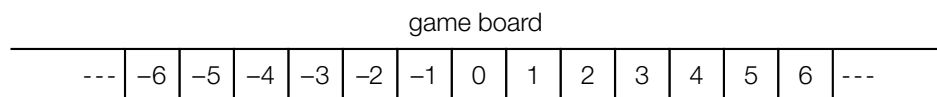

Maria and Tom are playing this quiz. Tom asks Maria the questions.

#### Task:

- a) For one game, the quiz ends when a token lands on the field with the number 2.

The variable  $A$  describes the event that a token lands on field number 2 after no more than 4 questions.

Maria answers each question correctly independently from the other ones with the same probability  $p$ .

- 1) Write down the probability  $P(A)$  in terms of  $p$ .

$$P(A) = \underline{\hspace{10cm}}$$

If  $p$  is increased, the probability  $P(A)$  increases as well.

- 2) Write down the value of  $p \in [0, 1]$  for which the probability  $P(A)$  increases the fastest (i. e. the instantaneous rate of change of  $P(A)$  is the greatest).

- b) Maria is asked exactly 100 questions during a different game. She answers each question correctly independently from the other ones with a probability of 0.8. The random variable  $Y$  represents the number on the field on which the token lands after answering these 100 questions.

- 1) Calculate the expectation value  $E(Y)$ .

$$E(Y) = \underline{\hspace{10cm}}$$

The random variable  $Y$  can be approximated by the normally distributed random variable  $Z$ . For this random variable,  $E(Y) = E(Z)$  holds and the standard deviation  $\sigma$  of  $Z$  is 8.

- 2) Determine the interval  $[z_1, z_2]$  that is symmetrical about the expectation value  $E(Z)$  for which  $P(z_1 \leq Z \leq z_2) = 95.4\%$  holds.

- c) During another game, Maria answers all the questions by guessing. She therefore answers each question correctly independently from the other ones with a probability of 0.5. For every even number  $n$  of questions with  $n \geq 2$  the following holds:

$$M(n) = \binom{n}{\frac{n}{2}} \cdot 0.5^n$$

- 1)  Interpret  $M(n)$  in the given context.

For every even number of questions with  $n \geq 10$ ,  $M(n)$  can be approximated by

$$\tilde{M}(n) = \sqrt{\frac{2}{\pi \cdot n}}$$

For every even  $n \geq 10$ , there exists an  $n^*$  so that  $\tilde{M}(n^*) = \frac{1}{2} \cdot \tilde{M}(n)$  holds.

- 2) Determine  $n^*$  in terms of  $n$ .

$$n^* = \underline{\hspace{10cm}}$$



## Task 28 (Part 2)

### Ozone Measurements

The gas ozone affects our health. Due to this, the ozone concentrations in different layers of the atmosphere are measured at measuring stations and using weather balloons.

Task:

- a) There is a weather station on the Hohe Warte in Vienna at 220 m above sea level. For a measurement series a weather balloon with an ozone reader is launched from there. The ozone reader starts its measurements as soon as the balloon has reached an altitude of 2 km above sea level.

Assume that the weather balloon (with a starting speed of 0 m/s) rises vertically and accelerates evenly with  $0.125 \text{ m/s}^2$  until the balloon reaches a speed of 6 m/s at time  $t_1$ . The time is measured in seconds and the altitude above sea level is measured in meters.

- 1) Determine the height of the weather balloon above the weather station at the point in time  $t_1$ .

After the point in time  $t_1$  the balloon continues to rise vertically at a constant speed of 6 m/s.

- 2) Determine how many seconds after the launch the ozone reader starts measuring.
- b) A weather balloon has a volume of  $6.3 \text{ m}^3$  at an air pressure of 1 013.25 hPa. Due to the decrease in air pressure while the balloon rises, the weather balloon expands further and further and becomes approximately spherical. It bursts at a diameter of  $d$  meters.

The air pressure, in terms of the altitude above sea level  $h$ , can be modelled by the function  $p$ , which assigns the air pressure  $p(h)$  to the altitude above sea level  $h$ .

The following holds:  $p(h) = 1\,013.25 \cdot \left(1 - \frac{0.0065 \cdot h}{288.15}\right)^{5.255}$  with  $h$  in m,  $p(h)$  in hPa

Assume the pressure  $p(h)$  and the volume  $V(h)$  of the weather balloon are indirectly proportional to each other.  $V(h)$  is the volume of the weather balloon at the altitude above sea level  $h$ .

- 1) Express the volume  $V(h)$  in terms of the altitude above sea level  $h$ .

$$V(h) = \underline{\hspace{10em}} \text{ with } h \text{ in m, } V(h) \text{ in m}^3$$

The weather balloon bursts at an altitude above sea level of  $h = 27\,873.6 \text{ m}$ .

- 2) Calculate the diameter  $d$  of the weather balloon in m at which the balloon bursts.



## Task 25 (Part 2)

### Solar Thermal Power Station

At a solar thermal power station, so-called *solar panels* convert sunlight into heat. This heat can be used to generate hot water or to heat buildings, for example.

Task:

- a) One solar panel in a solar thermal power station with length  $l$  creates an angle  $\varphi$  with the horizontal ground. This angle  $\varphi$  can be changed by a support of variable length  $s$  so that the solar panel is perpendicular to the sun's rays.

The sun's rays make an angle  $\varepsilon$  with the ground.

A model of the situation is shown in the diagram below.

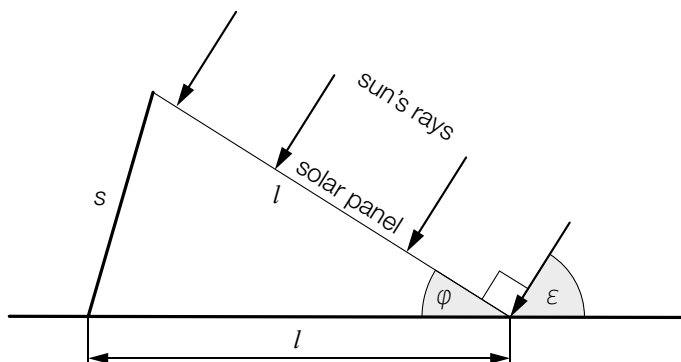

- 1)  A Write down a formula that can be used to calculate  $s$  by using  $l$  and  $\varepsilon$ .

$s =$  \_\_\_\_\_

The solar panel shown above has a length  $l = 1\,666$  mm. Over the course of a particular day, the angle  $\varepsilon$  takes values between  $14^\circ$  and  $65^\circ$  for this solar panel.

- 2) Write down the maximum value of  $s$ .

maximum value of  $s$ : \_\_\_\_\_ mm

- b) The power generated by a particular solar thermal power station on a cloudless day is modelled by the function  $P$ , for which:

$$P(t) = 0.0136 \cdot a^3 \cdot t^4 - 0.272 \cdot a^2 \cdot t^3 + 1.36 \cdot a \cdot t^2$$

$t$  ... time in h elapsed since sunrise ( $t = 0$ )

$P(t)$  ... power in kW at time  $t$

$a$  ... parameter

At sunrise and sunset, the power generated by the solar thermal power station is 0 kW. Between sunrise and sunset, the values of the function  $P$  are positive.

- 1) For this solar thermal power station, determine the value of the parameter  $a$  for a particular cloudless day on which the sun rises at 7:08 and sets at 18:38.

The work done by the solar thermal power station between two points in time  $t_1$  and  $t_2$  is given by  $\int_{t_1}^{t_2} P(t) dt$ .

- 2) Determine the work done (in kWh) by the solar thermal power station on this day.

## Task 26 (Part 2)

### Petrol Consumption

The petrol consumption of a particular small car in terms of its velocity can be modelled by the function  $B$ .

$$B(v) = 0.000483 \cdot v^2 - 0.0326 \cdot v + 2.1714 + \frac{66}{v} \quad \text{with } 20 < v < 150$$

$v$  ... velocity in km/h

$B(v)$  ... petrol consumption in litres per 100 km (L/100 km) for the velocity  $v$

#### Task:

- a) 1) Determine the percentage by which the petrol consumption increases when the velocity increases from 70 km/h to 90 km/h.

\_\_\_\_\_ %

The petrol consumption for a velocity of 40 km/h is 25 % lower than the petrol consumption for a velocity  $v_1$  where  $20 < v_1 < 40$ .

- 2) Determine the velocity  $v_1$ .

$v_1 =$  \_\_\_\_\_ km/h

- b) For higher velocities, the function  $B$  is to be approximated by a linear function  $f$  where  $f(v) = k \cdot v + d$  with  $k, d \in \mathbb{R}$  such that the following conditions hold:

$$f(100) = B(100)$$

$$f(130) = B(130)$$

- 1)  A Determine an equation of the function  $f$ .

$f(v) =$  \_\_\_\_\_

This approximation can be used if the difference between the values of the functions  $f$  and  $B$  is at most 0.3 L/100 km.

- 2) Write down the largest possible interval for the velocity for which the function  $f$  can be used as an approximation.

- c) 1) Using the function  $B$ , determine the velocity  $v_{\min}$  at which the petrol consumption is lowest as well as the corresponding petrol consumption  $B_{\min}$ .

$$v_{\min} = \underline{\hspace{4cm}} \text{ km/h}$$

$$B_{\min} = \underline{\hspace{4cm}} \text{ L/100 km}$$

The petrol consumption also depends on the tyre pressure.

The function  $g$  describes the petrol consumption in terms of the velocity  $v$  for a tyre pressure that is a little too low.

The following statement holds:  $g(v) = 1.02 \cdot B(v)$

- 2) Using the function  $g$ , determine the two velocities at which the petrol consumption is 2 L/100 km higher than  $B_{\min}$  when the tyre pressure is a little too low.

## Task 27 (Part 2)

### Population Growth in Africa

At the end of 2018, Africa had a population of around 1.3 billion people and displayed the highest level of population growth of all the continents.

Task:

- a) The diagram below shows the age pyramid of the African population in the year 2018. It can be read from the age pyramid, for example, that 4.5 % of the African population were men between the ages of 20 and 24 years and 4.4 % of the African population were women between the ages of 20 and 24 years in 2018. The age of a person is understood to be the number of complete years that a person has lived.

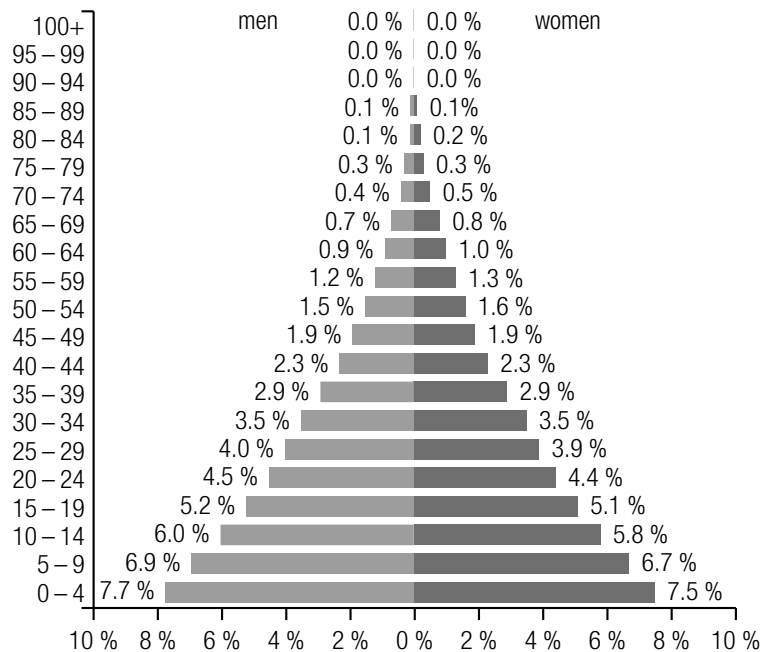

Data source: <https://www.populationpyramid.net/de/afrika/2018> [10.05.2019].

You should assume that each age within an age range occurs with equal frequency.

- 1) Using the age pyramid, determine the median  $m$  of the age of the African population in the year 2018.

$m =$  \_\_\_\_\_ years

- 2) Write down the number of African people who were younger than  $m$  years in 2018.

b) The diagram below shows the predicted population growth (given in millions) over the time period from 2010 to 2050 in a selection of African countries.

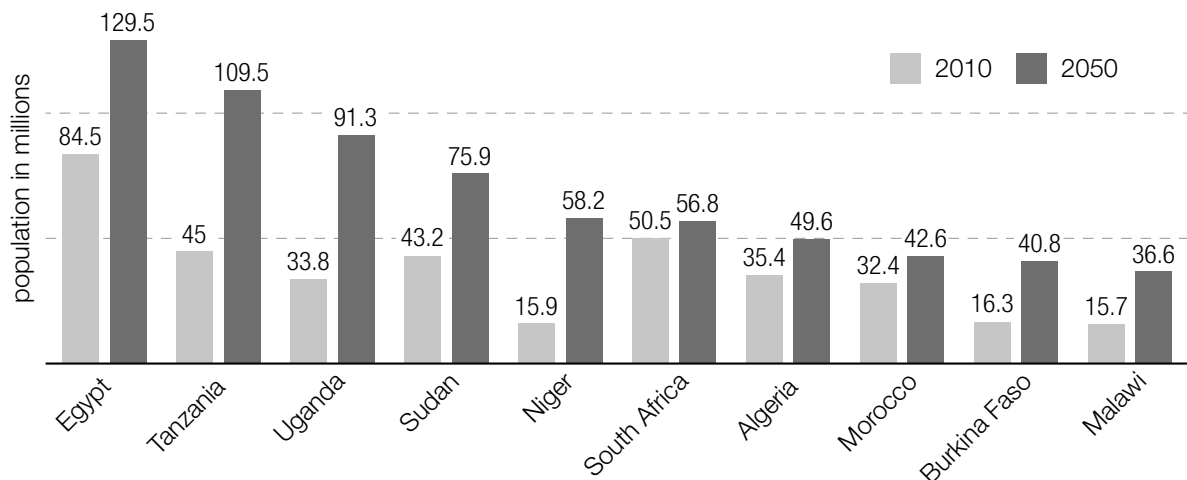

Data source: <https://de.statista.com/statistik/daten/studie/159204/umfrage/prognose-zur-bevoelkerungsentwicklung-in-afrika-bis-2050/> [10.05.2019].

- 1)  A Of the ten countries given, write down the country that will contribute most to the absolute population growth in Africa between 2010 and 2050 according to the prediction.
- 2) Of the ten countries given, write down the country in which there will be the largest relative population growth between 2010 and 2050 according to the prediction.

c) The table below shows the population growth for Nigeria in the time period from 1980 to 2010.

year	1980	1990	2000	2010
population in millions	73.5	95.3	122.4	158.6

- 1) Using the table, show that the population grew approximately exponentially in the time period from 1980 to 2010.

Assume that the population in Nigeria will continue to grow according to this exponential model.

- 2) Using the data from the years 2000 and 2010, write down the year in which the population of Nigeria will first be greater than 360 million.



- d) The table below shows the development of the average life expectancy of the African population since 1953.

year	average life expectancy in years
1953	37.5
1958	40.0
1963	42.3
1968	44.4
1973	46.6
1978	48.7
1983	50.5
1988	51.7
1993	51.7
1998	52.3
2003	53.7
2008	57.0
2013	60.2
2018	62.4

- 1) Determine the average annual increase  $k$  of the average life expectancy in the time period from 1953 to 2018.

It is assumed that the average life expectancy in Africa after 2018 increases each year by the constant value  $k$  determined above.

In 2018, the average life expectancy in Europe was 78.5 years.

- 2) Based on this assumption, write down the year in which the average life expectancy in Africa would reach the value in Europe for 2018.

## Task 28 (Part 2)

### Security Check

At the entrance of a particular stadium, a security check of at most three stages is undertaken to check the items people are bringing in and to seize prohibited items. If the first stage of this security check does not yield a clear result, then the second stage of the security check is carried out. If there is still no clear result, the third stage of the security check is implemented.

The first and second stages of the security check both last 15 s. The third stage lasts 300 s. A clear result is obtained at the first stage with a probability of 90 %. The second stage gives a clear result with a probability of 60 %.

Task:

a) The random variable  $X$  describes the time taken  $d$  (in s) for the security check for one person. Any possible waiting times that may occur are not considered.

1) Complete the table below by writing down the probability distribution of the random variable  $X$ .

$d$			
$P(X = d)$			

2) Determine the expectation value  $E(X)$ .

b) The value  $p$  gives the probability that a person brings a prohibited item with them. The probability that 2 people who are selected at random and independently from each other are both carrying a prohibited item is 10 %.

1)  A Determine the probability  $p$ .

2) Determine the probability that out of 10 people selected at random and independently from each other at least 5 people are carrying a prohibited item.

- c) The instantaneous rate of change of the number of people in the stadium can be described in terms of the time  $t$  by the function  $A$  where  $A(t) = a \cdot t^2 + b \cdot t + c$  with  $a, b, c \in \mathbb{R}$  and  $0 \leq t \leq 90$  ( $t$  in minutes,  $A(t)$  in people per minute). Admittance to the stadium begins at time  $t = 0$ .

At time  $t = 0$ , no people are entering the stadium; 45 min after admittance begins, 15 people per minute are entering the stadium. At this time, the instantaneous rate of change of the number of people entering the stadium per minute is greatest.

- 1) Determine the values of  $a$ ,  $b$  and  $c$ .
- 2) Write down the total number of people who have entered the stadium until the time  $t = 90$ .

## Task 25 (Part 2)

### Tea

Worldwide, tea is one of the most frequently consumed beverages.

#### Task:

- a) For the purpose of creating a model, it is assumed that the per capita consumption of tea in Austria increases each year in comparison to the previous year by the same percentage.

Based on this assumption, the function  $f$  gives the annual per capita consumption of tea in Austria from 2016 in terms of the time  $t$  ( $t$  in years,  $f(t)$  in litres).

- 1)  A Write down the type of function of  $f$ .

The annual consumption of tea in Austria in the year 2016 was 33 l per capita. The proportion of tea that was prepared using teabags in Austria in the year 2016 was 95 %.

The following assumptions have been made:

- The per capita consumption of tea in Austria has risen each year in comparison to the previous year by 2 % since 2016.
  - The proportion of tea that is prepared using teabags each year remains the same.
- 2) Write down how many litres of tea will be prepared per capita using teabags in Austria in the year 2026 based on the assumptions given above.



## Task 26 (Part 2)

### Global Warming

The *average global temperature* is the temperature of the whole surface of the Earth in a particular time period under particular conditions.

The development of the average global temperature can be forecast using climate models.

The average global temperatures for a number of years are shown below.

year	1900	1950	1955	1960	1965	1970	1975	1980
average global temperature (in °C)	13.80	13.87	13.89	14.01	13.90	14.02	13.94	14.16

year	1985	1990	1995	2000	2005	2010	2015
average global temperature (in °C)	14.03	14.37	14.37	14.31	14.51	14.55	14.72

The function  $T$  models the average global temperature in terms of the time  $t$  ( $t$  in years from the year 1900,  $T(t)$  in °C). The following equation holds:

$$T(t) = a \cdot e^{0.008 \cdot t} - 0.03 \cdot t + 11.1 \quad \text{with } a \in \mathbb{R}^+$$

#### Task:

- a) For a particular climate model, the value of  $a$  is  $a = 2.7$ .  
The function  $T$  has a local maximum or minimum when  $t = t_0$ .
- 1)  Determine  $t_0$ .
  - 2) Justify mathematically why the average global temperature has been rising increasingly faster from the time  $t_0$  according to this model.
- b) Various studies assume that the average global temperature in the year 2100 will be at least 1.5 °C and at most 4.5 °C higher than the average global temperature in the year 2000 (when it was 14.31 °C).
- 1) Show that the function  $T$  with  $a = 2.7$  confirms the assumption of these studies for the year 2100.
  - 2) Write down the smallest possible value  $a_{\min}$  and the largest possible value  $a_{\max}$  such that the function  $T$  confirms these studies.

$$a_{\min} = \underline{\hspace{10cm}}$$

$$a_{\max} = \underline{\hspace{10cm}}$$

- c) At the UN climate conference in Paris in the year 2015, a new international climate agreement was reached in which the increase in the average global temperature should be limited. According to this agreement, the average global temperature in the year 2100 can be at most 15.3 °C.

In order to fulfil this climate agreement, the average rate of change of the average global temperature from the year 2015 can be at most a particular value  $k$  ( $k$  in °C per year).

- 1) Determine  $k$ .

It is assumed that the average global temperature from the year 2015 increases linearly and the average rate of change of the average global temperature per year does actually correspond to the value  $k$ .

- 2) Based on this assumption, write down an equation of the linear function  $M$  that can be used to model the annual average global temperature (in °C)  $t$  years after 2015.

## Task 27 (Part 2)

### E-Mobility

The number of electric cars has increased in Austria in the last few years. The reasons for this include, among others, technical improvements, such as the increasing capacity of batteries and shorter charging times.

The *Battery capacity* is understood to be the maximum energy  $E$  (in kilowatt hours, kWh) that can be stored in the battery of the electric car. This energy is converted into a different form of energy while driving and is replenished when the car is charged.

The *charging time* is understood to be the time that is required to fully charge a (nearly) empty battery.

#### Task:

- a) The diagram below shows the number of electric cars in Austria for the time period from 31<sup>st</sup> December 2015 to 31<sup>st</sup> August 2018. For the years 2015 to 2017, the number shown is the value for the end of the respective year; for the year 2018, the number shown is the value up to the end of August.

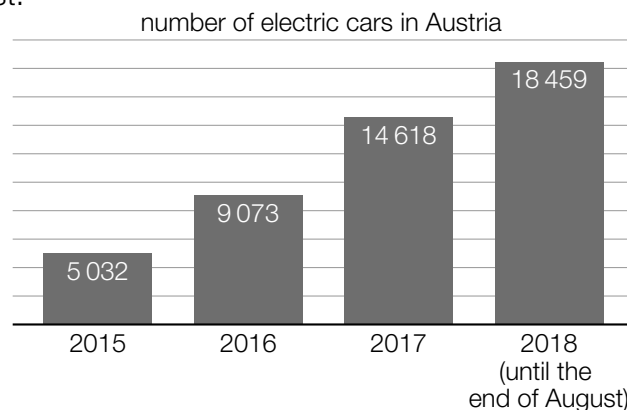

Data source: Statistik Austria, [https://www.statistik.at/web\\_de/statistiken/energie\\_umwelt\\_innovation\\_mobilitaet/verkehr/strasse/kraftfahrzeuge\\_-\\_bestand/index.html](https://www.statistik.at/web_de/statistiken/energie_umwelt_innovation_mobilitaet/verkehr/strasse/kraftfahrzeuge_-_bestand/index.html) [23.03.2020].

The difference equation  $B_{n+1} = B_n \cdot a + b$  gives the development of the number of electric cars in Austria starting from the year 2015 for the years 2016 and 2017.

For this equation, the following conditions hold:

- $B_0$  is the number at the end of the year 2015.
- $B_1$  is the number at the end of the year 2016.
- $B_2$  is the number at the end of the year 2017.

- 1) Write down the values of  $a$  and  $b$ .

$$a = \underline{\hspace{10cm}}$$

$$b = \underline{\hspace{10cm}}$$

So that the difference equation given above also holds for the year 2018, the number of electric cars would have had to have risen in the rest of 2018 by a particular number.

- 2) Determine this number.



- b) The battery capacity (in kWh) is the product of the charging capacity (in kW) and the charging time (in h). For example, in order to charge a (nearly) empty battery with a battery capacity of 22 kWh with a charging capacity of 11 kW, a charging time of 2 h is necessary.

The function  $f$  describes the charging time  $f(P)$  of a battery with a battery capacity of 22 kWh in terms of the charging capacity  $P$  ( $P$  in kW,  $f(P)$  in h).

- 1)  Write down  $f(P)$ .

$$f(P) = \underline{\hspace{10cm}}$$

The typical charging capacity of a private charging station lies in the capacity interval [2.3 kW, 3.7 kW].

- 2) For a battery with a battery capacity of 22 kWh, write down the time interval for the charging time that corresponds to this capacity interval.

- c) The following assumptions are made in order to model an electric car driving on a particular test track:
- The electric car drives along the whole test track at constant velocity.
  - There is a linear relationship between the energy requirement of this electric car and the corresponding constant velocity.

This electric car has an energy requirement of 12.9 kWh for a constant velocity of 70 km/h on this test track.

The electric car has an energy requirement of 20.9 kWh for a constant velocity of 110 km/h on this test track.

The function  $E$  gives the energy requirement  $E(v)$  in terms of the velocity  $v$  with  $50 \leq v \leq 130$  ( $v$  in km/h,  $E(v)$  in kWh).

- 1) Write down  $E(v)$ .

$$E(v) = \underline{\hspace{10cm}}$$

The battery of this electric car has a battery capacity of 41 kWh and is fully charged before driving along the test track. After driving along the test track, there are still 30.22 kWh available.

- 2) Determine the (constant) velocity  $v_1$  with which the electric car drove along the test track.

## Task 28 (Part 2)

### Muesli Bar

A new muesli bar is about to be launched. The manufacturer of this muesli bar produces 100 000 bars.

The possibility of winning an instant cash prize is displayed on all the wrappers of the muesli bars. The amount won can be read from the inside of the wrapper once it has been opened. The manufacturer of the muesli bar states:

There are

- 9000 instant cash prizes of € 2 each
- 900 instant cash prizes of € 5 each
- 100 instant cash prizes of € 65 each

that will be paid out.

All muesli bars that are produced will be delivered to shops. The distribution of the muesli bars occurs at random.

#### Task:

- a) Once all of the production costs have been taken into consideration, each of the 100 000 muesli bars costs on average € 1 to produce.

The sales price of a muesli bar is to be determined such that the manufacturer earns a profit of at least € 80,000 after all the instant cash prizes in the muesli bars have been paid out.

- 1) Determine the lowest possible sales price  $p$  of the muesli bars given these conditions.
  - 2) Write down the percentage by which the lowest possible sales price  $p$  can be reduced if the muesli bars are sold without cash prizes and the profit is still at least € 80,000.
- b) The random variable  $X$  describes the amount of the instant cash prize per muesli bar sold.
- 1) Determine the expectation value  $E(X)$ .

A customer buys 4 muesli bars.

- 2) Determine the probability that the customer wins at least one instant cash prize.

- c) From experience it is known that 95 % of the muesli bars meet a minimum weight requirement.

A random sample of 1 000 muesli bars is selected. The binomially distributed random variable  $Y$  describes the number of muesli bars in this random sample that meet the minimum weight requirement.

- 1)  A Determine the standard deviation  $\sigma(Y)$  of the random variable  $Y$ .

$$\sigma(Y) = \underline{\hspace{15em}}$$

- 2) Interpret the result of the calculation shown below in the given context.

$$P(Y \geq 933) \approx 0.99$$

## Task 25 (Part 2)

### System Reliability

A system is defined as a machine that consists of more than one component. There is a certain probability that each component of a system may function correctly or that it might fail. If individual components fail to work, it depends on the design of the system whether the system as a whole continues to work or whether it fails as well.

The *reliability of a component* is the probability that the component functions correctly, i. e. does not break down. This holds true for a certain period of time and under certain conditions.

The *reliability of a system* is the probability that the system functions correctly. (It is assumed that breakdowns of components happen independently of one another.) The probability of the complementary event is called probability of failure.

We distinguish between two simple types of systems:

- series systems:

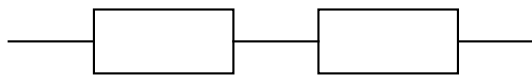

A series system functions only when all its components function.

- parallel systems:

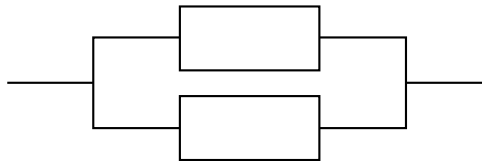

A parallel system functions when at least one of its components functions.

### Task:

- a) The following system  $A$  is given:



Let  $p_1$  be the probability of component  $T_1$  and  $p_2$  be the probability of component  $T_2$ .

Consider the reliability of system  $A$  as a function  $z_A$  in terms of  $p_1$  and  $p_2$ .

Write down  $z_A(p_1, p_2)$ .

$z_A(p_1, p_2) =$  \_\_\_\_\_

The components of a different system with the same design have the same reliabilities  $p_1 = p_2 = 0.7$ . The probability of failure is to be reduced to a quarter of the current probability of failure.

Write down which value the reliability  $p_{\text{new}}$  (for both components) needs to take.

$p_{\text{new}} =$  \_\_\_\_\_

b) System  $B$  is given:

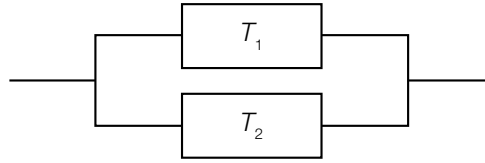

Both components  $T_1$  and  $T_2$  have the same reliability  $p$ .

Consider the reliability of system  $B$  as a function  $z_B$  of  $p$ .

Write down  $z_B(p)$ .

$z_B(p) =$  \_\_\_\_\_

Show by calculation that the function  $z_B$  is strictly monotonically increasing in the interval  $(0, 1)$ .

c) Given are two systems  $C$  and  $D$ :

System  $C$ :

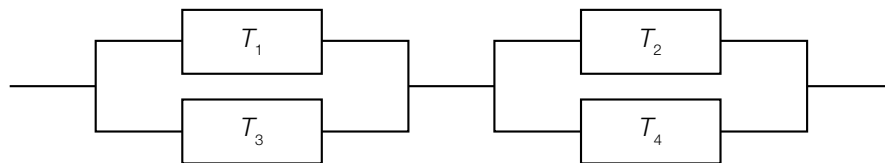

System  $D$ :

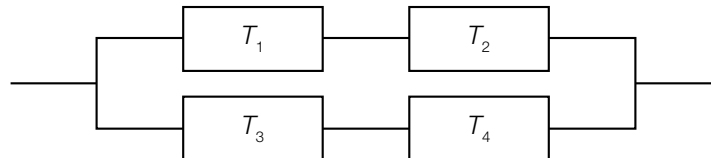

Every component  $T_1, T_2, T_3$  and  $T_4$  has the same reliability  $p$ .

The reliability  $z_C$  of system  $C$  is a function of  $p$  and can be described by the equation

$$z_C(p) = p^4 - 4 \cdot p^3 + 4 \cdot p^2.$$

Determine the quotient  $\frac{1 - z_C(0.9)}{1 - z_C(0.8)}$  and interpret this value for system  $C$ .

The reliability  $z_D$  of system  $D$  is a function of  $p$ .

Justify why  $z_C(p) > z_D(p)$  holds true for all  $p \in (0, 1)$ .

Use either an equation of  $z_D$  or provide justification on basis of the design of systems  $C$  and  $D$ .

## Task 26 (Part 2)

### Carpet of Algae

The surface of an  $800 \text{ m}^2$  pond is covered with a carpet of algae that continues to grow. Over the course of five weeks, the area of the carpet is measured at the end of each respective week. All measured values are listed in the table below. At the beginning of measurement, the carpet of algae covers  $4 \text{ m}^2$ .

$t$ (in weeks)	0	1	2	3	4	5
$A(t)$ (area of the carpet of algae after $t$ weeks in $\text{m}^2$ )	4	7	12.25	21.44	37.52	65.65

Mathematically, the growth of the carpet of algae can be modelled in different ways.

#### Task:

- a) In the first five weeks, the area  $A(t)$  of the algae carpet can be approximated by an exponential function  $A$ , since the carpet covers only a small proportion of the pond ( $A(t)$  in  $\text{m}^2$ ,  $t$  in weeks).

Determine the percentage by which the area grows each week and write down an equation of  $A$ .

$$A(t) = \underline{\hspace{10cm}}$$

At the end of the fifth week,  $30 \text{ m}^2$  of algae will be harvested. This will be repeated regularly at the end of every following week.

Determine how often this can be repeated, assuming that the area of the carpet continues to grow by the same percentage in between harvests.

- b)  Determine the average weekly change (in  $\text{m}^2$  per week) of the area of the algae carpet from the end of the second week until the end of the fourth week of measurement.

The exponential function used above does not describe the growth of the algae well when already a large area is covered, as algae growth will slow down at some point, depending on the size of the pond. A more realistic model will therefore take this aspect into account as well.

Dependent of the area  $A$  of the carpet of algae, the rate of growth can be modelled by the function  $w$  with equation  $w(A) = k \cdot A \cdot (800 - A)$ . Here,  $A$  is given in  $\text{m}^2$ ;  $k \in \mathbb{R}^+$  is the so-called growth parameter, depending on the type of the algae.

Determine the area  $A_1$  of the algae carpet, at which the rate of growth is highest.

$$A_1 = \underline{\hspace{10cm}} \text{ m}^2$$

- c) The observed time period is extended beyond the five weeks mentioned in the introduction. The area of the carpet of algae  $t$  weeks after the beginning of the observation is modelled by the function  $A_2$  with equation  $A_2(t) = \frac{800}{1 + 199 \cdot e^{-800 \cdot k \cdot t}}$  ( $A_2(t)$  in  $\text{m}^2$ ,  $t$  in weeks).

Determine the value of the parameter  $k \in \mathbb{R}^+$  using the value given in the table at the time  $t = 5$ .

If this model is used, at which point of time does the carpet of algae cover 90 % of the pond's surface for the first time?

Determine this point of time.

## Task 27 (Part 2)

### First Names in Austria

Over decades, Statistik Austria, the statistical office of the Republic of Austria, has been collecting the first names that parents give their children. Here, the office only looks at the very first name of a child (if a child is given more than one first name). In addition, certain identical names or names that share the same background, like *Sophie*, *Sofie* and *Sofia*, are grouped together under one name.

For many years now, *Anna* and *Lukas* have been among the most popular names. Out of the children born in the year 2015 (40 777 girls, 43 604 boys), 2 144 girls were named *Anna* and 1 511 boys were named *Lukas*.

#### Task:

- a) For a statistical survey, 30 girls and 30 boys born in the year 2015 are selected randomly.

A Determine the probability that at least one of the girls in this sample is called Anna.

Determine the probability that in this sample at least one of the girls is called Anna and one of the boys is called Lukas.

- b) In the year 1995, the relative proportion of the ten most popular first names for boys was 37.07 %. In 2005, it was 24.28 %. In the year 2015, it was 20.91 %.

This development of the relative proportion of the ten most popular names is described by a quadratic function  $f$  with equation  $f(t) = a \cdot t^2 + b \cdot t + c$  where  $a, b, c \in \mathbb{R}$  and  $a \neq 0$ . Here,  $t$  stands for the number of years from 1995, thus  $f(0) = 0.3707$  holds.

Determine the values of  $a$ ,  $b$  and  $c$  and write down an equation of  $f$ .

In which year did the relative proportion of the ten most popular names for boys fall below one third for the first time?

Write down the corresponding year.



- c) The random variable  $X$  models the number of girls born in Upper Austria in the year 2015, who were called *Anna*. This variable is taken to be binomially distributed with parameters  $n = 7041$  and  $p = 0.0526$ .

Determine the expectation value  $\mu$  and the standard deviation  $\sigma$  of the random variable  $X$ .

$$\mu \approx \underline{\hspace{10cm}}$$

$$\sigma \approx \underline{\hspace{10cm}}$$

In fact, in the year 2015, the name *Anna* was chosen most frequently in all nine provinces, whereby the percentage was highest in Upper Austria. In Upper Austria, 7 041 girls were born in 2015. Out of these, 494 were given the first name *Anna*.

$494 - \mu = c \cdot \sigma$  holds for  $c \in \mathbb{R}^+$ .

Determine  $c$  and interpret the value of  $c$  in the given context.

## Task 28 (Part 2)

### Wings for Life World Run

The *Wings for Life World Run* is a fun run taking place in a lot of countries at the same time. One special feature of this run is that no fixed distance has to be covered.

Around the world, all runners start at the same time at 11:00 UTC (Coordinated Universal Time). From the same starting point as the runners, the so-called *Catcher Car* starts 30 minutes later and drives along the course. The car increases its speed according to a pre-defined schedule. Whenever someone is overtaken by the Catcher Car, the race is over for this person. The distance a participant was able to cover until overtaken by the Catcher Car is the result that this person gets.

For the speed of the Catcher Car, the following values were specified until the year 2018 (these serve as a model for the processing of the following tasks):

Time	Speed
from 11:30 to 12:30	15 km/h
from 12:30 to 13:30	16 km/h
from 13:30 to 14:30	17 km/h
from 14:30 to 15:30	20 km/h
from 15:30 to 16:30	20 km/h
from 16:30	35 km/h

#### Task:

- a) A person runs at a constant speed, until he or she is overtaken by the Catcher Car. This person is overtaken during the Catcher Car's 15 km/h phase. The time  $t$  the person spends on the course is dependent of the speed  $v$  this person is running at.

Write down an expression that can be used to determine  $t$  assuming that  $v$  is known (with  $t$  in h and  $v$  in km/h).

$t =$  \_\_\_\_\_

In the year 2016, the (constant) speed of one person participating in the run was 9 km/h. One year later, his or her (constant) speed at the event was 10 % higher.

Write down, by what percentage the distance covered by this person until he or she is overtaken by the Catcher Car had thus increased.

The distance covered had thus increased by approximately \_\_\_\_\_ %.

- b) A particular well-trained person runs at a constant speed during the first hour and takes 5 minutes per kilometre. After that, he or she slows down. From this time on (that is for  $t \geq 1$ ), his or her speed can be modelled by the function  $v$  in terms of the time spent running. For the speed  $v(t)$ , the following equation holds:

$$v(t) = 12 \cdot 0.7^{t-1} \text{ with } t \text{ in h and } v(t) \text{ in km/h}$$

Interpret the expression  $12 + \int_1^b v(t) dt$  with  $b \geq 1$  in the given context.

Determine the time of day, when this person is overtaken by the Catcher Car.

Time: \_\_\_ \_\_\_ : \_\_\_ \_\_\_ UTC

- c) A group of runners is overtaken during the Catcher Car's 20 km/h phase. Juri therefore concludes that this group has not covered less than 40 km and not covered more than 88 km until they being overtaken by the Catcher Car. Leo replies to this statement, "Your statement is true but I could give you a smaller interval which holds true as well."

A State whether Leo's claim is correct and justify your decision.

In Vienna's 2017 run, the fastest female participant covered a distance of 51.72 km until she was overtaken by the Catcher Car.

Determine her average speed  $\bar{v}$ .

$\bar{v} =$  \_\_\_\_\_ km/h

## Task 25 (Part 2)

### Braking

The braking distance  $s_B$  is the length of the stretch of road a vehicle covers after applying the brakes until it comes to a stop. The variables that determine the braking distance are the velocity  $v_0$  of the vehicle at the moment the brakes are applied and the deceleration due to braking  $b$ . The braking distance  $s_B$  can be calculated using the formula  $s_B = \frac{v_0^2}{2 \cdot b}$  ( $v_0$  in m/s,  $b$  in m/s<sup>2</sup>,  $s_B$  in m).

The stopping distance  $s_A$  takes into account both the braking distance and the distance covered during the reaction time  $t_R$ . This so-called *thinking distance*  $s_R$  can be calculated using the formula  $s_R = v_0 \cdot t_R$  ( $v_0$  in m/s,  $t_R$  in s,  $s_R$  in m).

The stopping distance  $s_A$  is equal to the sum of the thinking distance  $s_R$  and the braking distance  $s_B$ .

#### Task:

- a) 1) A Write down a formula that can be used to calculate the velocity  $v_0$  in terms of the braking distance  $s_B$  and the deceleration due to braking  $b$ .

$$v_0 = \underline{\hspace{10cm}}$$

- 2) Put a cross next to each of the two correct statements.

The thinking distance $s_R$ is directly proportional to the velocity $v_0$ .	<input type="checkbox"/>
The braking distance $s_B$ is directly proportional to the velocity $v_0$ .	<input type="checkbox"/>
The braking distance $s_B$ is indirectly proportional to the deceleration due to braking $b$ .	<input type="checkbox"/>
The stopping distance $s_A$ is directly proportional to the velocity $v_0$ .	<input type="checkbox"/>
The stopping distance $s_A$ is directly proportional to the reaction time $t_R$ .	<input type="checkbox"/>

- b) The formulae often used by driving schools to approximate the thinking and braking distances (both in m) are:

$$s_R = \frac{v_0}{10} \cdot 3 \quad \text{and} \quad s_B = \left(\frac{v_0}{10}\right)^2 \quad \text{with } v_0 \text{ in km/h and both } s_R \text{ and } s_B \text{ in m}$$

- 1) By rearranging appropriately, show that the formula used to approximate the thinking distance for a reaction time of around one second gives roughly the same result as the formula for  $s_R$  given in the introduction.
- 2) Determine which value is used for the deceleration due to braking in the formula used to approximate the braking distance.

c) The deceleration due to braking  $b$  can be assumed to be  $8 \text{ m/s}^2$  in dry conditions,  $6 \text{ m/s}^2$  in wet conditions and at most  $4 \text{ m/s}^2$  in icy conditions.

1) Write down the fraction by which the braking distance is longer in wet conditions than in dry conditions given the same velocity.

A vehicle is being driven with a velocity of  $v_0 = 20 \text{ m/s}$ . The stopping distance in icy conditions is longer than in dry conditions.

2) Assuming that  $t_R = 1 \text{ s}$ , determine the minimum absolute increase in the stopping distance under icy conditions in comparison to dry conditions

d) A vehicle's brakes are applied at time  $t = 0$ . The velocity  $v(t)$  of the vehicle in the time period  $[0, 3]$  can be modelled by the function  $v$ , the acceleration  $a(t)$  can be modelled by the function  $a$ , and the distance  $s(t)$  covered in this time period can be modelled by the function  $s$  ( $v(t)$  in  $\text{m/s}$ ,  $a(t)$  in  $\text{m/s}^2$ ,  $s(t)$  in  $\text{m}$ ,  $t$  in  $\text{s}$ ).

1) Interpret the meaning of the definite integral  $\int_0^3 v(t) dt$  in the given context.

Each of the six diagrams below shows the graph of an acceleration function  $B$ , the graph of a velocity function  $v$ , and the graph of a distance function  $s$  in the time interval  $[0, 3]$ .

2) Put a cross next to the diagram that shows the three corresponding graphs of a vehicle that is braking for three seconds.

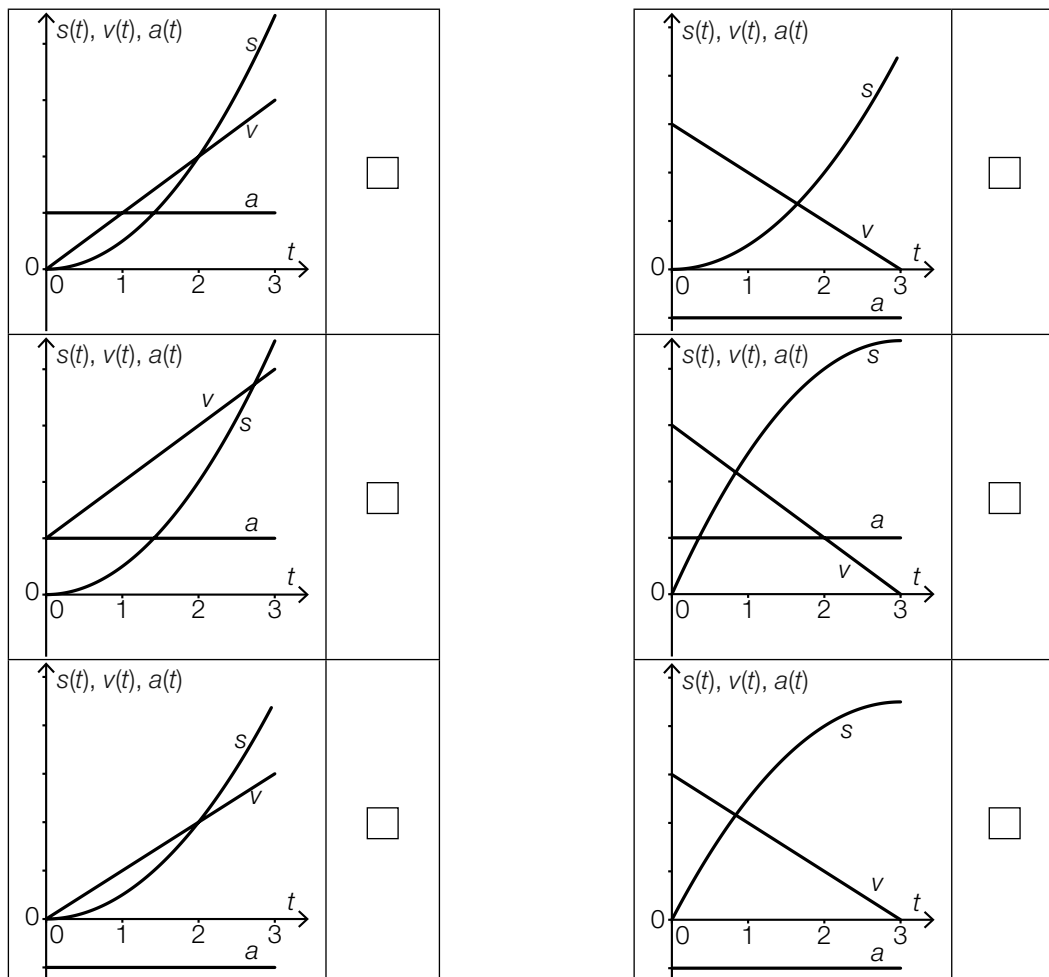

## Task 26 (Part 2)

### Cost Function

A producer is interested in the monthly costs accrued in the production of a particular product. The production costs for this product in terms of the number  $x$  (in units ME) produced (the production volume) can be modelled by a third degree polynomial function  $K$  where  $K(x) = 8 \cdot 10^{-7} \cdot x^3 - 7,5 \cdot 10^{-4} \cdot x^2 + 0,2405 \cdot x + 42$  ( $K(x)$  in monetary units, GE).

Task:

- a) 1)  For this product, determine the average increase in costs per additional unit produced in the interval [100 ME, 200 ME].
- 2) Determine the production volume above which the marginal costs increase.
- b) The production volume  $x_{\text{opt}}$  for which the unit cost function  $\bar{K}$  where  $\bar{K}(x) = \frac{K(x)}{x}$  is minimal, is the optimal production volume for the cost function  $K$ .
- 1) Determine the optimal production volume  $x_{\text{opt}}$ .

The producer calculates the production costs for the production volume  $x_{\text{opt}}$ . He determines that these costs amount to 65 % of the available capital for the production of this product.

- 2) Determine the capital the producer has available for the production of this product.
- c) For the sales price  $p$ , the revenue can be modelled in terms of the production volume  $x$  by a linear function  $E$  where  $E(x) = p \cdot x$  ( $E(x)$  in GE,  $x$  in ME,  $p$  in GE/ME). A condition of this model is that every unit produced is also sold.
- 1) Determine the value of  $p$  such that the maximum profit is generated through the sale of 600 ME.

The maximum possible production volume is 650 ME.

- 2) Determine the range of production volumes for which the producer makes a profit.

- d) For another product made by this producer, the production costs (in GE) for various production volumes (in ME) are shown in the table below.

production volume (in ME)	50	100	250		500
production cost (in GE)	197	253	308	380	700

These production costs can be modelled by a third degree polynomial function  $K_1$  where  $K_1(x) = a \cdot x^3 + b \cdot x^2 + c \cdot x + d$  with  $a, b, c, d \in \mathbb{R}$ .

- 1) Determine the values of  $a, b, c$  and  $d$ .
- 2) Determine the production volume that is missing in the table above.

## Task 27 (Part 2)

### Fibonacci Numbers and the Golden Ratio

The so-called *Fibonacci Numbers* are defined for  $n \in \mathbb{N}$  and  $n > 2$  by the difference equation  $f(n) = f(n-1) + f(n-2)$  with initial values  $f(1) = 1$  and  $f(2) = 1$ .

For large values of  $n$ , the ratio  $f(n) : f(n-1)$  approaches the *golden ratio*  $\phi = \frac{1 + \sqrt{5}}{2}$ .

Task:

- a) 1)  Write down the value of  $n$  for which the ratio  $f(n) : f(n-1)$  first corresponds to the golden ratio  $\phi$  to two decimal places.

For Fibonacci numbers, the following equation holds for  $k \in \mathbb{N}$  and  $k > 2$ :

$$f(n+k) = f(n-1) \cdot f(k) + f(n) \cdot f(k+1)$$

- 2) Show that this equation holds for  $n = 3$  and  $k = 5$ .

- b) One method of approximating Fibonacci numbers using a simple explicit expression is the approximation  $f(n) \approx g(n) = \frac{1}{\sqrt{5}} \cdot \left(\frac{1 + \sqrt{5}}{2}\right)^n$  where  $n \in \mathbb{N} \setminus \{0\}$ .

The number 832040 is a Fibonacci number, which means there exists an  $n \in \mathbb{N}$  for which  $f(n) = 832040$  and  $g(n) \approx 832040$ .

- 1) Determine the value of this  $n$ .

An exact explicit method of calculating the Fibonacci numbers  $f(n)$  is the Moivre/Binet formula:

$$f(n) = \frac{1}{\sqrt{5}} \cdot (x_1^n - x_2^n)$$

In this formula,  $x_1 = \phi$  and  $x_2$  are the solutions to the equation  $x^2 + a \cdot x - 1 = 0$  where  $a \in \mathbb{R}$ .

- 2) Determine the values of  $a$  and  $x_2$ .



## Task 28 (Part 2)

### Cinema

A cinema has three screens. The first screen has 185 seats, the second screen has 94, and the third screen has 76.

New films are normally first shown on Thursdays. The owner of the cinema assumes that on a Thursday on which a new film is being shown, each seat in all three screens will be filled with a probability of 95 %.

#### Task:

a) Let  $X$  be a binomially distributed random variable with parameters  $n = 355$  and  $p = 0.95$ .

1) Describe the meaning of the expression  $1 - P(X < 350)$  in the given context.

At the end of the school year, a school rents all three screens to show the same film at the same starting time. All of the seats have been assigned, and each viewer receives a ticket for a specific seat in one of the three screens. In addition to the seat number, all of the tickets also have a distinct, consecutive ticket number. Directly before the film is shown, two ticket numbers are drawn by lot. The two people who have the corresponding tickets receive a large portion of popcorn each.

2) Write down the probability that these two people have tickets for the same screen.

b) The owner of the cinema would like to know how satisfied his customers are with the cinema (the selection of food, the cleanliness etc.). He conducts a survey of 628 customers, and 515 of these customers say that they are generally satisfied with the cinema.

1)  A On the basis of this survey, write down a symmetrical 95 % confidence interval for the relative proportion of all the cinema's customers that are generally satisfied with the cinema.

A second survey is conducted in which four times as many customers are asked. The relative proportion of customers who are generally satisfied with the cinema in this survey is exactly the same as the result of the first survey.

2) Write down in numerical terms how this increase in sample size influences the width of the symmetrical 95 % confidence interval calculated using the result of the first survey.

## Task 25 (Part 2)

### Use of Antibiotics

The development of a bacteria culture can be influenced by the addition of antibiotics which should eventually lead to the death of the culture due to the toxic effect of the antibiotic.

In certain cases this development can be approximated by the function  $B: \mathbb{R}_0^+ \rightarrow \mathbb{R}$ :

$$B(t) = b \cdot e^{k \cdot t - \frac{c}{2} \cdot t^2} \quad \text{with } b, c, k \in \mathbb{R}^+$$

$t$  ... time in hours

$B(t)$  ... number of bacteria in millions at the time  $t$

$b$  ... number of bacteria in millions at the time  $t = 0$

$k$  ... constant

$c$  ... parameter of the toxic effect

#### Task:

- a) The function  $B$  has exactly one positive maximum or minimum  $t_1$ .
- 1) Determine  $t_1$  in dependency of  $k$  and  $c$ .
  - 2) Describe what effect enlarging  $c$  with a given  $k$  has on the position of the maximum or minimum  $t_1$  of the function  $B$ .
- b) The function  $B_1: \mathbb{R}_0^+ \rightarrow \mathbb{R}$  with  $B_1(t) = 20 \cdot e^{2 \cdot t - 0.45 \cdot t^2}$  describes the number of bacteria of a certain bacteria culture in millions dependent on the time  $t$ .

At a certain time  $t_2 \neq 0$  the bacterial culture reaches its original population of 20 million.

- 1)  A Determine  $t_2$ .
  - 2) Interpret the meaning of  $B_1'(t_2)$  in the given context with use of the appropriate unit.
- c) The function  $B_2: \mathbb{R}_0^+ \rightarrow \mathbb{R}$  with  $B_2(t) = 5 \cdot e^{4 \cdot t - \frac{t^2}{2}}$  describes the number of bacteria in a culture in millions. This culture shows its maximum at the time  $t = 4$ .
- 1) Determine the time  $t_3$  at which the biggest decrease in bacteria occurs.
  - 2) Write down what percentage of the maximum number of bacteria is left at the time  $t_3$ .

## Task 26 (Part 2)

### Tennis

Tennis is a recoil game played by two or four people during which a tennis ball is tossed over a net. The playing field is a rectangle and is split into two equal rectangles by the net (see Illustration 1). For a game between two people the playing field is 23.77 m long and 8.23 m wide. The playing field is limited by the lines on the ground along the base line and side lines. The net has a maximum height of 1.07 m.

Illustration 1:

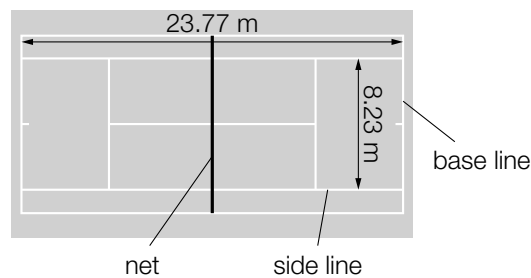

Task:

a) The function  $f: \mathbb{R}_0^+ \rightarrow \mathbb{R}$  with  $f(x) = -0.0007 \cdot x^3 + 0.005 \cdot x^2 + 0.2 \cdot x + 0.4$  describes the trajectory of a tennis ball until it hits the ground for the first time. In this scenario,  $x$  describes the horizontal distance from the position at the time of the serve and  $f(x)$  the height of flight of the tennis ball above the ground ( $x$  and  $f(x)$  in m). The flight pattern of the tennis ball starts between the two side lines at the base line and the plane, in which the flight pattern lies, runs parallel to the side line of the tennis court.

- 1)  A Determine in which horizontal distance the tennis ball reaches its maximum height measuring from the point of the serve.

horizontal distance from point of the serve: \_\_\_\_\_ m

- 2) Determine through calculation if the tennis ball lands in the opponents field or behind the base line.

- b) If a tennis ball falls onto the ground perpendicularly (without rotation), then it recoils again perpendicularly. The restitution coefficient  $r$  is a gauge for the ability of a tennis ball to jump.

The equation  $r = \frac{v_2}{v_1}$  applies for the jump of the tennis ball, in which  $v_1$  describes the value of the velocity before impact and  $v_2$  describes the value of the velocity after the impact.

The difference of the vertical velocities directly before and after the impact is described by the equation  $\Delta v = v_2 - (-v_1)$  due to the different orientation.

- 1) Find a term that describes  $\Delta v$ , so that  $\Delta v$  is dependent on  $v_1$  and  $r$ .

$$\Delta v = \underline{\hspace{10cm}}$$

A tennis ball impacts perpendicularly at a speed of  $v_1 = 4.4$  m/s. The restitution coefficient for this tennis ball is approximately  $r = 0.6$ . The contact time with the ground is 0.01 s.

- 2) Calculate the average acceleration  $a$  (in  $\text{m/s}^2$ ) of a tennis ball in vertical direction during the time of the impact.

$$a = \underline{\hspace{10cm}} \text{ m/s}^2$$

- c) A player wins a five-set match as soon as he has won three sets. To win a set one usually must win six games, whereby each game is worth one point.

For different probabilities  $p$  for having won a game the resulting probabilities  $m$  to win a five-set match have been determined and can be seen in the table below.

$p$	$m$
0.5	0.5
0.51	0.6302
0.55	0.9512
0.6	0.9995
0.7	1.000

The probability that player  $A$  wins a game is 2 percent points greater than the probability that the opponent  $B$  will win a game.

- 1) Determine by how many percent points the probability that player  $A$  wins a five-set match is greater than that of the opponent  $B$  winning.

When playing against a different, weaker player  $C$ , player  $A$  has an advantage of 10 percent points to win a game.

- 2) Show that the probability that player  $A$  wins a five-set match against opponent  $C$  is 50.94 percent greater than during a five set match against opponent  $B$ .

## Task 27 (Part 2)

### Elevator Ride

The velocity of elevators for transporting people can vary greatly depending on construction and building height.

The following illustration shows the time-acceleration diagram for an elevator ride of 20 seconds. At the beginning and end of the ride the elevator is at a standstill. The time  $t$  is measured in seconds, the acceleration  $a(t)$  in  $\text{m/s}^2$ . The acceleration values were determined by sensors and the course of the acceleration is modelled by a derivable function  $a$ .

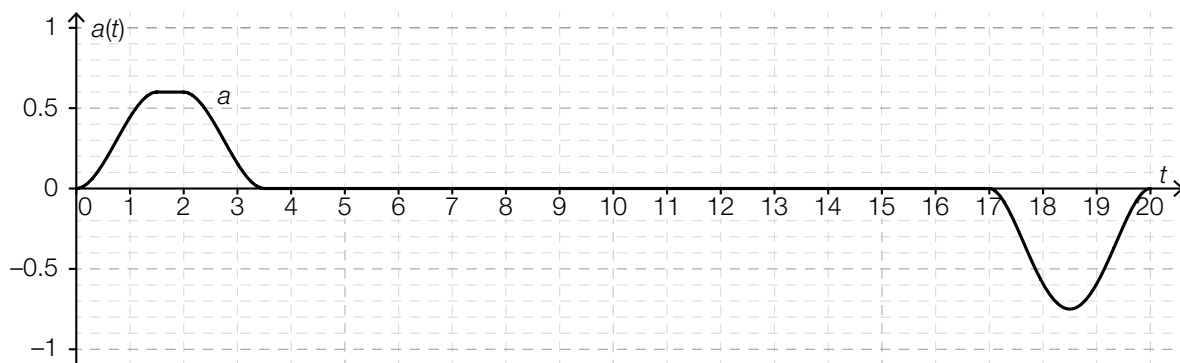

#### Task:

- a) 1)  Write down the appropriate interval for each later mentioned section of the elevator ride.

elevator is decelerating: \_\_\_\_\_

elevator is travelling at a constant speed: \_\_\_\_\_

Kim claims that the velocity of the elevator during the time interval  $[1.5 \text{ s}, 2 \text{ s}]$  remains constant.

- 2) Argue if Kim's statement is correct and justify your decision.

- b) 1) Using the illustration, determine the approximate maximal velocity  $v_{\max}$  during the graphed elevator ride.

The graph of the function  $a$  encloses two areas together with the  $t$ -axis during the time intervals  $[0, 3.5]$  and  $[17, 20]$ .

- 2) Based on the given context, justify why these two areas must be the same size.

- c) An elevator producer is planning to construct a new elevator. The acceleration of this elevator during the first three seconds is described by the derivable function  $a_1: [0, 3] \rightarrow \mathbb{R}$  with
- $$a_1(t) = \begin{cases} 0.6 \cdot t^2 \cdot (3 - 2 \cdot t) & \text{for } 0 \leq t < 1 \\ 0.6 & \text{for } 1 \leq t < 2 \\ 0.6 \cdot (t - 3)^2 \cdot (2 \cdot t - 3) & \text{for } 2 \leq t \leq 3 \end{cases}$$

( $t$  in s,  $a_1(t)$  in  $\text{m/s}^2$ ).

- 1) Calculate the increase in speed of this elevator during the time interval  $[0, 3]$ .

For the path of an elevator ride, certain criteria regarding the acceleration must be fulfilled. The *jolt*, the instantaneous change in acceleration, should lie between  $-1 \text{ m/s}^3$  and  $1 \text{ m/s}^3$  for the entire elevator ride.

- 2) Verify if this elevator fulfils the criteria for the jolt at the time  $t = 1$ .

## Task 28 (Part 2)

### E-Book

The term *e-book* (abr. for electronic book) describes books in a digital form.

The two diagrams regarding Germany show the estimated values for the growth of the e-book market.

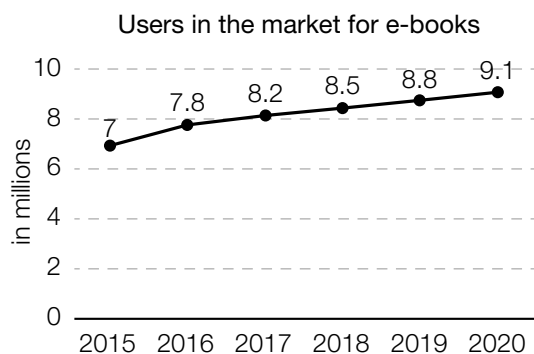
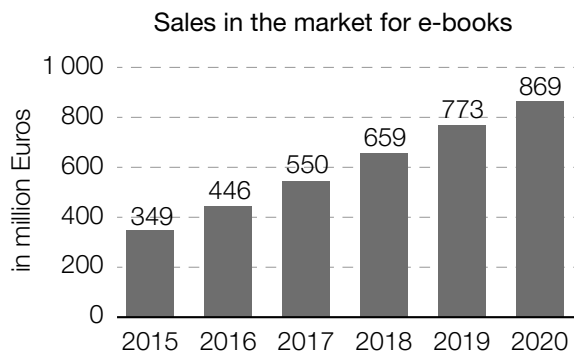

Source: <http://www.e-book-news.de/20-prozent-wachstum-pro-jahr-statista-sieht-deutschen-e-book-markt-im-aufwind/> [19.06.2019] (adapted).

### Task:

- a) 1) Calculate the absolute and relative change for the estimated sales per user in Germany in the time range from 2015 to 2020.

absolute change: € \_\_\_\_\_

relative change: \_\_\_\_\_

- 2) Calculate the difference quotient for the estimated sales per user in Germany for the time range from 2015 to 2020.

- b) The estimated increase in sales in the market for e-books from 349 million Euros in 2015 to 869 million Euros in 2020 is described by the source as follows:

“20 percent increase per year”

- 1)  A Determine how high the estimated sales  $U(2017)$  for the year 2017 would have had to be, if the sales had increased by 20 % annually starting with the estimated sales value in 2015.

$U(2017) =$  \_\_\_\_\_ million Euro

Someone describes the estimated increase in sales in the market for e-books from 349 million Euros in the year 2015 to 869 million Euros in the year 2020 as follows:

“a million Euro increase per year”

- 2) Calculate  $a$ .

- c) The population of Germany in the year 2015 was approximately 82.18 million. The population of Austria was approximately 8.58 million. Someone asks themselves the following question: “How many people were using e-books in Austria in 2015?”

- 1) Answer the question assuming that the proportion of e-book users in Austria is the same as the (estimated) proportion of the e-book users in Germany in 2015.

Number: \_\_\_\_\_ people

500 people are randomly selected in Austria in the year 2020. The binomially distributed random variable  $X$  describes the number of people from this selection that are e-book users. The probability that a person is an e-book user is assumed at 12 %.

- 2) Calculate the probability that at least 50 e-book users were randomly selected.



## Task 1

### Properties of a Third Degree Polynomial Function

Let  $f$  be a third degree polynomial function with equation  $f(x) = a \cdot x^3 + b \cdot x$  with coefficients  $a, b \in \mathbb{R} \setminus \{0\}$ .

Task:

- a) Justify why the function  $f$  has exactly three distinct real roots if the coefficients  $a$  and  $b$  have different signs.

A The gradient of the tangent to the graph of  $f$  at the point where  $x = 0$  is equal to the value of the coefficient  $b$ . Justify why this statement is true.

- b) Determine the relationship between the coefficients  $a$  and  $b$  such that  $\int_0^1 f(x) dx = 0$  holds.

Justify why it follows that  $f$  has a root in the interval  $(0, 1)$  if it is assumed that  $\int_0^1 f(x) dx = 0$  holds. Sketch a possible graph of one such function  $f$  in the coordinate system provided below.

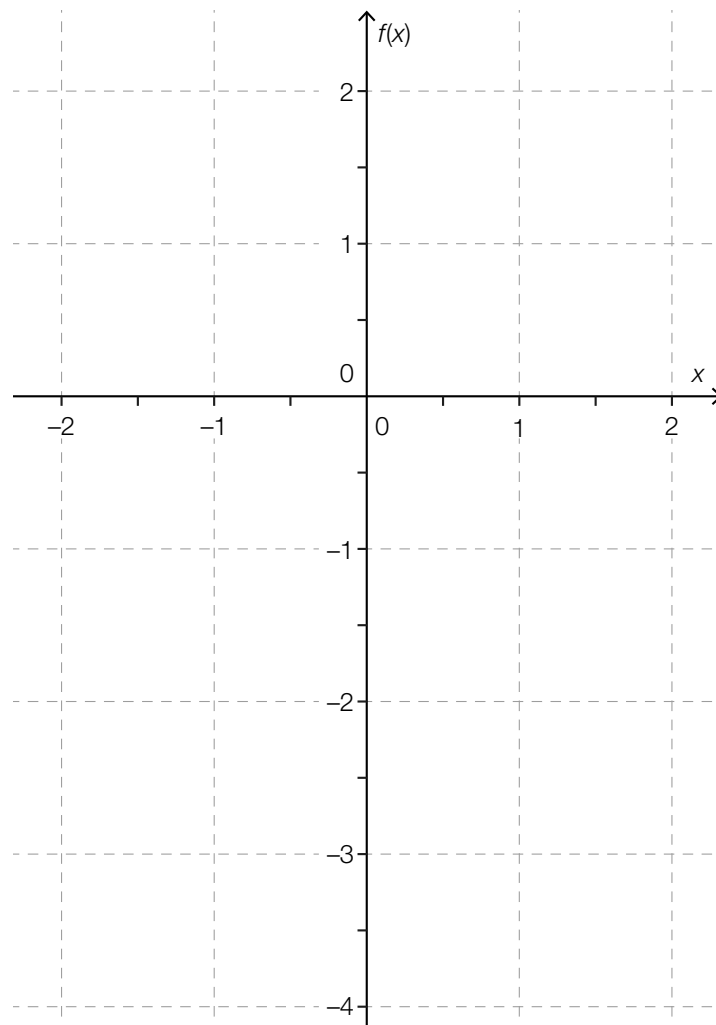

## Task 2

### Hop

Hop is a fast growing climbing plant. The modelling function  $h: \mathbb{R}_0^+ \rightarrow \mathbb{R}^+$  where

$h(t) = \frac{a}{1 + b \cdot e^{k \cdot t}}$  with  $a, b \in \mathbb{R}^+$ ,  $k \in \mathbb{R}^-$  can be used to approximate the height of a plant of a particular type of hop at time  $t$ , where  $h(t)$  is given in metres and  $t$  in weeks.

The table below shows the heights of a hop plant measured from the beginning of April ( $t = 0$ ).

Time (in weeks)	0	2	4	6	8	10	12
Height (in m)	0.6	1.2	2.3	4.2	5.9	7.0	7.6

From these values, the values of the parameters  $a = 8$ ,  $b = 15$  and  $k = -0.46$  for the modelling function  $h$  were determined.

Task:

- a)  A Using the modelling function  $h$ , write down an expression that can be used to calculate by how many metres the hop plant has grown in the time interval  $[0, t_1]$ .

Using the modelling function  $h$  and your expression, determine by how many metres the plant grew in the first 10 weeks and write down how much this value differs from the actual value measured as a percentage.

- b) If the growth is modelled by the function  $h$ , there is a time  $t_2$  at which the plant grows the fastest. Write down an equation that can be used to calculate  $t_2$  and determine the value of  $t_2$ .

Determine the corresponding maximal rate of growth and sketch the shape of the function  $g$  that is based on the modelling function  $h$  and describes the rate of growth of the hop plant in terms of  $t$  in the coordinate system provided below using the maximum value you have calculated above.

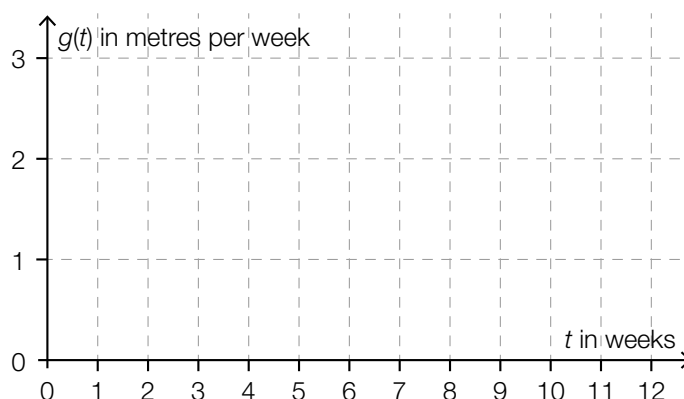

- c) Write down a linear function  $h_1$  that gives the correct heights at  $t = 0$  and  $t = 12$  according to the table and interpret the gradient of this linear function in the given context.

$$h_1(t) = \underline{\hspace{15em}}$$

Using the shape of the graphs of  $h$  and  $h_1$ , justify why there are at least two points in time at which the rate of growth of the plant has the same value as the gradient of  $h_1$ .

- d) As the value of  $t$  increases,  $h(t)$  tends to a value, which is denoted by  $h_{\max}$ . Using the equation given for the modelling function  $h$ , show by calculation that the parameter  $k$  (where  $k < 0$ ) has no influence on  $h_{\max}$  and specify  $h_{\max}$ .

Favourable weather conditions can mean that the hop plant grows higher and more quickly i. e. that the plant reaches a value larger than  $h_{\max}$  at an earlier point in time. Write down how  $a$  and  $k$  would have to be changed to reflect this growth.

## Task 3

### Measuring Distances

During public transport checks carried out by the police, distances are measured. In the following description, the term *distance* refers to the length of a line segment and the term *separation distance* refers to a period of time.

If the distance between the back end of the car in front and the front end of the car behind is  $\Delta s$  metres, then the separation distance is the time  $t$  in seconds that it would take the car behind to cover the distance  $\Delta s$ .

The box plot below shows the separation distances that were collected during a check of 1 000 vehicles. All of the vehicles that were checked were travelling at a speed of approximately 130 km/h.

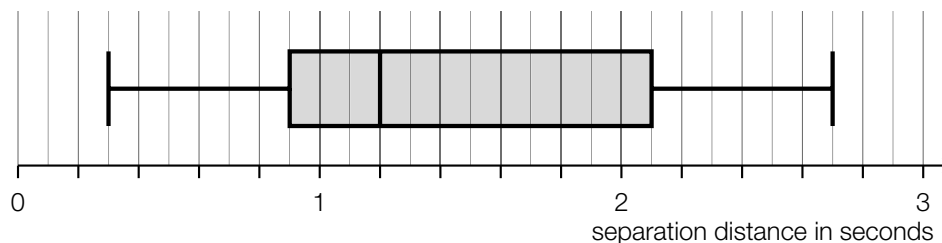

Task:

- a)  Write down the first quartile  $q_1$  and the third quartile  $q_3$  of the separation distances and state the meaning of the region from  $q_1$  to  $q_3$  in the given context.

According to the values from an Austrian motor club, around three quarters of drivers keep a distance of at least 30 metres from the car in front when driving at speeds of around 130 km/h. Write down whether or not the data displayed in the box plot above can roughly confirm these values and give a reason for your answer.

- b) A common rule of thumb recommended for the motorway is to keep a separation distance of at least 2 seconds. A person claims that it can be read from the box plot that at least 20 % of the drivers kept to this separation distance. Write down a larger percentage that can be read from the box plot that definitely corresponds to this separation distance and justify your decision.

Assume that the percentage that you have found can be used as the probability that the recommended separation distance is adhered to. Write down the probability that at least six out of a sample of ten independent, randomly chosen measurements from these checks adhere to the recommended separation distance of at least two seconds.

- c) During a different check, a vehicle that is to be checked is also filmed in the 300 metres preceding the checkpoint so that the measurement cannot be distorted if the vehicle in front of the vehicle to be checked slows down.

During the measuring process, vehicle  $A$  travels with constant speed and requires nine seconds to cover the 300 metres that are filmed. Draw the distance covered  $s_A(t)$  in terms of the time  $t$  in the distance-time diagram provided below ( $s_A(t)$  in metres,  $t$  in seconds) and write down the speed at which the vehicle is travelling in km/h.

Vehicle  $B$  also requires nine seconds to cover the 300 metres, but its speed is continually decreasing during this time. Draw a possible graph of the corresponding distance-time function  $s_B$  that starts from the origin in the space provided below.

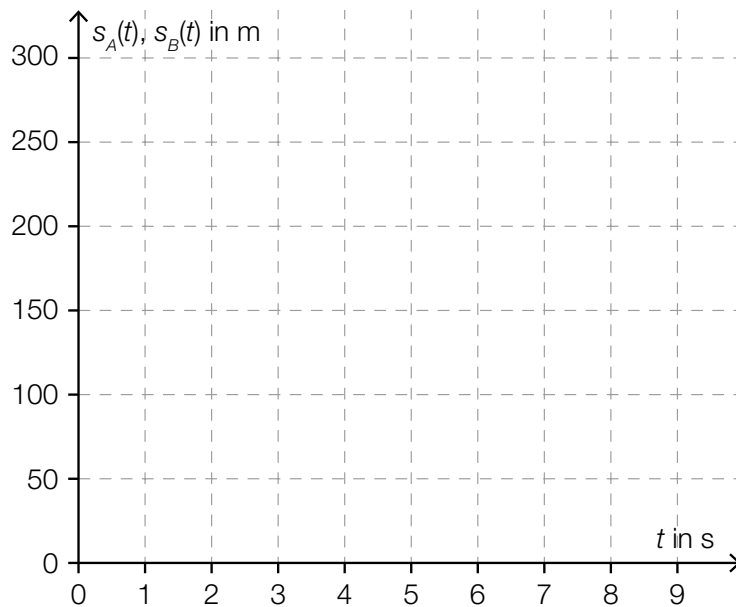

## Task 4

### Bitcoin

Bitcoin (abbreviation: BTC) is a digital artificial currency. The market value of Bitcoin is determined by supply and demand.

In this task, those people who use Bitcoin are referred to as Bitcoin users.

The diagram below shows the Bitcoin-Euro exchange rate from the 11<sup>th</sup> March 2015 to the 11<sup>th</sup> March 2016. The scale on the left-hand side shows the absolute value of a Bitcoin in euros; the scale on the right-hand side shows the percentage change from the 11<sup>th</sup> March 2015.

Bitcoin-Euro exchange rate (BTC – EUR)



Data source: <http://www.finanzen.net/devisen/bitcoin-euro-kurs> [11.03.2017] (adapted).

Task:

- a) Write down in which month from April 2015 to December 2015 the absolute value of the Bitcoin-Euro exchange rate fell the most (from the beginning of the month to the end of the month) and write down this exchange rate loss in euros.

Month: \_\_\_\_\_

Exchange rate loss: \_\_\_\_\_

Let  $K_1$  be the Bitcoin-Euro exchange rate at the beginning of this particular month,  $K_2$  be the Bitcoin-Euro exchange rate at the end of this particular month, and  $AT$  be the number of days in the month considered.

Determine the approximate value of the expression  $\frac{K_2 - K_1}{AT}$  and interpret the result in the given context.

- b) At the beginning of January 2016, around 15 million Bitcoins were in circulation. The number of Bitcoins in circulation  $t$  years after 2009 is approximately  $f(t) = 21 \cdot 10^6 - 21 \cdot 10^6 \cdot e^{-0.18 \cdot t}$ . At the beginning of January 2009, there were  $f(0)$  Bitcoins in circulation.

Determine and interpret the relative (percentage) change in the number of Bitcoins in circulation in the time period  $[7, 8]$ .

Write down an equation that can be used to calculate the time from which only one million Bitcoins can be put in circulation and determine this time.

- c) A study of the demographics of Bitcoin users found that globally 88 % of Bitcoin users are male. It is to be determined how high this percentage is in Austria. A large number of people were questioned. This survey found that 171 of those asked were Bitcoin users and 138 of these 171 people were male.

A Using this data, write down a symmetrical 95 % confidence interval for the unknown proportion of male Bitcoin users out of all Bitcoin users in Austria.

Write down the minimum confidence level that would need to be used so that the global proportion of 88 % would be in this interval.

## Task 1

### Quadratic Function

The graph of a second degree polynomial function  $f$  crosses the positive vertical axis at the point  $A = (0, y_A)$  and has the point  $B = (x_B, 0)$  in common with the positive  $x$ -axis. Point  $B$  is also a maximum or minimum of  $f$ .

The function  $f$  has equation  $f(x) = \frac{1}{4} \cdot x^2 + b \cdot x + c$  with  $b, c \in \mathbb{R}$ .

Task:

- a)  Write down whether  $c$  has to be greater than zero, equal to zero or less than zero and justify your answer.

Write down whether  $b$  has to be greater than zero, equal to zero or less than zero and justify your answer.

- b) The function  $f'$  is the first derivative of the function  $f$ .  
Write down whether the following statement is true or false and justify your answer: Point  $B$  is a point of intersection of the graphs of  $f$  and  $f'$ .

For all values of  $b$  there is exactly one value of  $x$ ,  $x_t$ , with the following property: At  $x_t$ ,  $f$  and  $f'$  have the same gradient. Write down  $x_t$  in terms of  $b$ .

- c) Write down which relationship has to hold between  $b$  and  $c$  so that the maximum or minimum  $x_B$  of  $f$  is also a zero of  $f$ .

Write down the coefficients  $b$  and  $c$  of the function  $f$  in terms of  $x_B$ .



## Task 2

### Interaction of Sound Waves

In the simplest case, a sound can be modelled by a sine function  $s$  where  $s(t) = a \cdot \sin(b \cdot t)$  for  $a, b \in \mathbb{R}^+$ . The maximum value of a function that represents a sine wave of this kind is known as the amplitude. The number of periods per second is known as the frequency  $f$  and is given in Hertz (Hz).

For the frequency,  $f$ , the formula  $f = \frac{1}{T}$  (with  $T$  in seconds) holds;  $T$  is the (smallest) period length of the sine wave ( $T \in \mathbb{R}^+$ ).

Three particular sounds are described by the functions  $h_1$ ,  $h_2$  and  $h_3$  shown below. The time  $t$  ( $t \geq 0$ ) is measured in milliseconds (ms).

$$h_1(t) = \sin(2 \cdot \pi \cdot t)$$

$$h_2(t) = \sin(2.5 \cdot \pi \cdot t)$$

$$h_3(t) = \sin(3 \cdot \pi \cdot t)$$

The interaction of multiple sounds results in a new sound.

The function  $h$  with  $h(t) = h_1(t) + h_2(t) + h_3(t)$  describes a sound.

The acoustic pressure of a sound depends on time and can be modelled by the function  $p$  where  $p(t) = \bar{p} \cdot \sin(\omega \cdot t)$ . In this function,  $\bar{p}$  and  $\omega$  are constants.

The acoustic pressure is given in pascals (Pa).

#### Task:

- a) Write down a formula in terms of  $c$  for the period length  $T$  (in ms) of a sound modelled by the function  $g$  with  $g(t) = \sin(c \cdot \pi \cdot t)$  where  $c \in \mathbb{R}^+$  and  $t$  in ms.

The effective value  $p_{\text{eff}}$  of the acoustic pressure of a sine wave with period length  $T$  (in ms) can be calculated using the formula  $p_{\text{eff}} = \sqrt{\frac{1}{T} \int_0^T p^2(t) dt}$ .

Determine the effective value of the acoustic pressure of a sine wave of a sound for  $\bar{p} = 1$  and  $\omega = 2 \cdot \pi$ .

- b) Write down (e. g. with the help of an appropriate graph) the (smallest) period length  $T$  (in ms) of the function  $h$ .

Write down the frequency,  $f$ , of the function  $h$  in Hertz.

- c) Write down (e. g. with the help of an appropriate graph) the amplitude of the function  $h$  and the time  $t \geq 0$  (in ms) at which this amplitude is first reached.

Justify why the amplitude of  $h$  is not equal to the sum of the three amplitudes of the functions  $h_1$ ,  $h_2$  and  $h_3$ .

- d) For a good surround sound experience (e.g. in a home cinema), it is desirable if the five speakers of a five-channel sound system are arranged as shown in the left-hand diagram below (view from above). This arrangement can be modelled using a Cartesian coordinate system (units in metres) as shown in the right-hand diagram below.

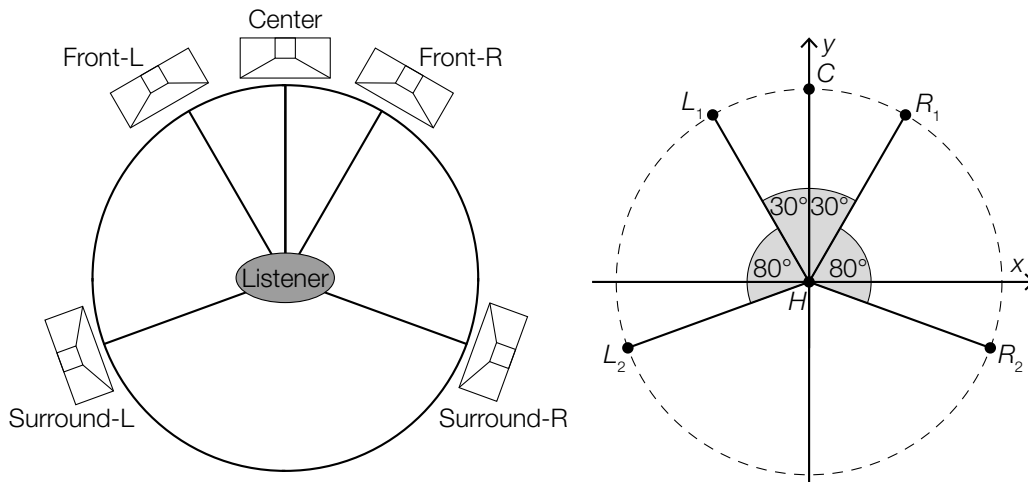

Source: <https://de.wikipedia.org/wiki/5.1> [23.04.2018] (adapted).

In this case, each of the five speakers ( $C$ ,  $L_1$ ,  $L_2$ ,  $R_1$ ,  $R_2$ ) is 2 m away from the listener ( $H$ ). The point  $H$  lies at the origin.

**A** Write down the Cartesian coordinates of  $R_1$ .

Determine the distance between  $L_2$  and  $R_2$ .

## Task 3

### Salmon Population

The Canadian scientist W. E. Ricker investigated the number of offspring of fish in North American rivers in terms of the number of fish in the parent generation. In 1954, he published Ricker's Model. The expected number of fish  $R(n)$  in a successor generation can be approximated from the number of fish  $n$  in the respective parental generation using the so-called reproduction function  $R$  where  $R(n) = a \cdot n \cdot e^{-b \cdot n}$  with  $a, b \in \mathbb{R}^+$ . After four years at most of living in the sea, salmon return to their place of birth to spawn, i. e. to lay their eggs. After spawning, most salmon die.

As part of his study, Ricker investigated the sockeye salmon population in the Skeena River in Canada. The table shown below gives the salmon population in the years from 1908 to 1923. The numbers given are averages of the observed population size in four consecutive years.

Time period	Observed salmon population (in thousands of fish)
01.01.1908–31.12.1911	1 098
01.01.1912–31.12.1915	740
01.01.1916–31.12.1919	714
01.01.1920–31.12.1923	615

Data source: [http://jmahaffy.sdsu.edu/courses/s00/math121/lectures/product\\_rule/product.html](http://jmahaffy.sdsu.edu/courses/s00/math121/lectures/product_rule/product.html) [01.02.2018] (adapted).

Using this data for the salmon population in the Skeena River, the values for the parameters of the reproduction function  $R$   $a = 1.535$  and  $b = 0.000783$  have been determined ( $R(n)$  and  $n$  in thousands of fish).

#### Task:

- a) For the salmon population in the Skeena River for  $n > 0$ , determine the solution  $n_0$  to the equation  $R(n) = n$  using the reproduction function in thousands of fish.

A Interpret  $n_0$  in the given context.

- b) Determine the coordinates of the maximum or minimum  $E = (n_E, R(n_E))$  of the reproduction function  $R$  in terms of  $a$  and  $b$  and show that  $n_E$  is a local maximum for all  $a, b \in \mathbb{R}^+$ .

Write down for which values of the parameter  $a$  the population  $R(n_E)$  of the following generation is always greater than the previous population  $n_E$ .

- c) Represent the data for the salmon population (in thousands of fish) given in the table above in a histogram. The absolute frequencies should be represented by the areas of rectangles.

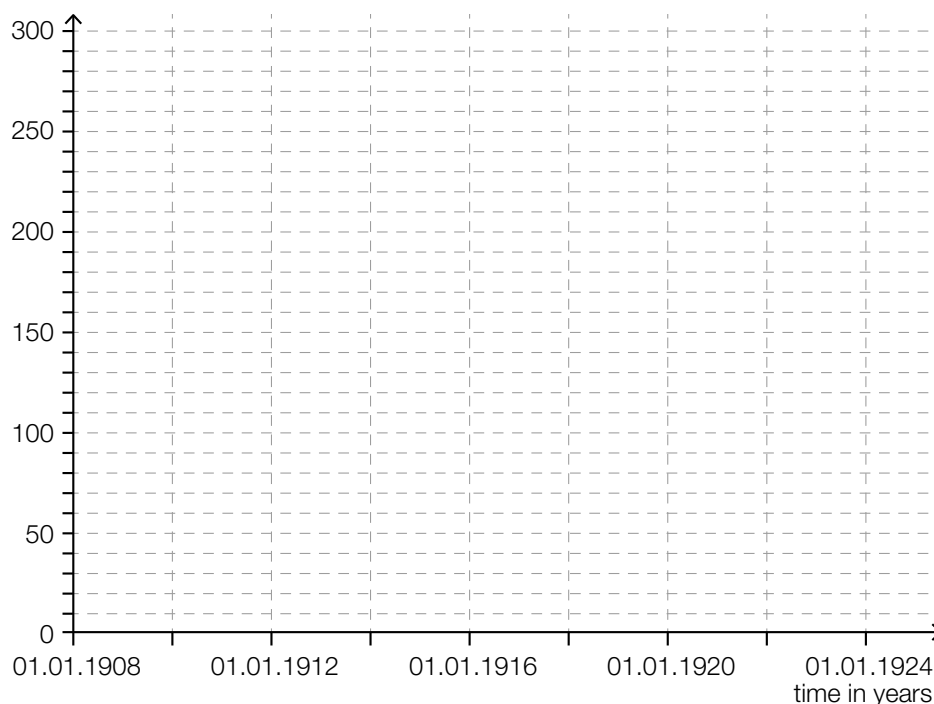

Ricker's model is one of the standard models for describing population developments. Nevertheless, the values calculated using the reproduction function may deviate from the observed values.

Taking the observed average salmon population of 1098 (in the period between 1908 and 1911) as a starting point, calculate the expected average salmon population in the Skeena River for each of the four-year-periods between 1912 and 1923 according to the expectations based on the reproduction function.

Time period	Calculated salmon population (in thousands of fish)
01.01.1912–31.12.1915	
01.01.1916–31.12.1919	
01.01.1920–31.12.1923	

## Task 4

### Roulette

Roulette is a game of chance in which a natural number between 0 and 36 is selected at random by a rolling ball. Each of the 37 numbers has an equal probability of being selected, and the result of each turn is independent from previous turns. The region that corresponds to the number zero is green, half of the rest of the numbers are coloured red, and the other half are coloured black. The table below shows a selection of bets that can be placed and their corresponding pay-outs. A “profit of 35-times the initial stake” means, for example, that if the bet is won then the player receives their initial stake plus 35 times that amount (so, in total, 36 times their original stake).

single number (from 0 to 36)	profit of 35-times the initial stake
red/black	profit of the initial stake
even/odd (without zero)	profit of the initial stake

One of the most famous strategies for playing roulette is the Martingale System. In this system, a person always places the same “simple” bet (e. g. on “red” or “even”). If the bet is lost, the player doubles their stake in the next game. If this game is also lost, the player doubles their stake again and continues this pattern game after game. Using this strategy, as soon as a game is won, the game series ends and the player has won a profit amounting to their initial stake in the game series.

#### Task:

- a) The random variable  $X$  describes how often the ball lands on a particular number in 80 games. Determine the probability that the ball lands on a specific number at least four times during the 80 games.

A player would like to increase their chances of winning and proceeds as follows: During a string of e. g. 37 games, he records the number the ball lands on. He assumes, in the subsequent games, that the ball will land on the numbers that he has not recorded and thus places bets on these numbers.

Write down whether the player can increase his chances of winning using this strategy and justify your answer.

- b) A player uses the Martingale System and always places a bet on “red”. The player stops playing either when she wins or once the casino’s highest stake of € 10,000 has been reached and allows no further doubling of the stake.

The table below shows how quickly the stakes can increase from an initial stake of € 10 in the Martingale System if a player has a “losing streak”.

Round	Stake in €
1	10
2	20
3	40
4	80
5	160
6	320
7	640
8	1 280
9	2 560
10	5 120

- A Determine the probability that the player loses all ten rounds in this Martingale series.

By calculating the expectation value of the profit, show that the Martingale System is not desirable for the player despite the very low probability of losing ten consecutive games.

## Task 1

### Third Degree Polynomial Function

Let  $f_t$  be a third degree polynomial function with equation  $f_t(x) = \frac{1}{t} \cdot x^3 - 2 \cdot x^2 + t \cdot x$ . For the parameter  $t$  holds:  $t \in \mathbb{R}$  and  $t \neq 0$ .

Task:

- a)  Find the local maxima and minima of  $f_t$  in terms of  $t$ .

When  $x = t$ , the equations  $f_t(t) = 0$ ,  $f_t'(t) = 0$  and  $f_t''(t) = 2$  hold for the function  $f_t$ . Describe the shape of the graph of  $f_t$  at  $x = t$ .

- b) Determine the point  $x_0$  dependant of  $t$ , where the concavity of  $f_t$  changes.

Show by calculation that the concavity of the graph of  $f_t$  at  $x = 0$  is independent of the value chosen for the parameter  $t$ .

- c) The function  $A$  describes the area of the region bounded by the graph of  $f_t$  and the  $x$ -axis in terms of  $t$  in the interval  $[0, t]$ , where  $t > 0$ . The function  $A: \mathbb{R}^+ \rightarrow \mathbb{R}_0^+$ ,  $t \mapsto A(t)$ , is a polynomial function.

Write down the equation and the degree of the function  $A$ .

Determine the ratio  $A(t) : A(2 \cdot t)$ .

- d) Show by means of calculation that  $f_{-1}(x) = f_1(-x)$  holds for all  $x \in \mathbb{R}$ .

Describe how the graph of the function  $f_{-1}$  can be developed from the graph of  $f_1$ .

## Task 2

### Capacitor

A capacitor is an electrical component that can store electric charge as well as the resulting electric energy.

The so-called *plate capacitor* is a simple version of a capacitor. It consists of two opposing electrically conductive plates, which are called *capacitor plates*.

The ratio between the stored charge  $Q$  and the applied (DC) voltage  $U$  is called the capacity  $C$ .

It is known that  $C = \frac{Q}{U}$ , where  $C$  is given in Farad.

Task:

- a) When a capacitor with a particular capacity  $C$  is charged up to the charge  $Q_1$ , the voltage  $U(Q_1)$  measured has the value  $U_1$ .

A Sketch the voltage  $U$  with respect to the charge  $Q$ , while charging the capacitor.

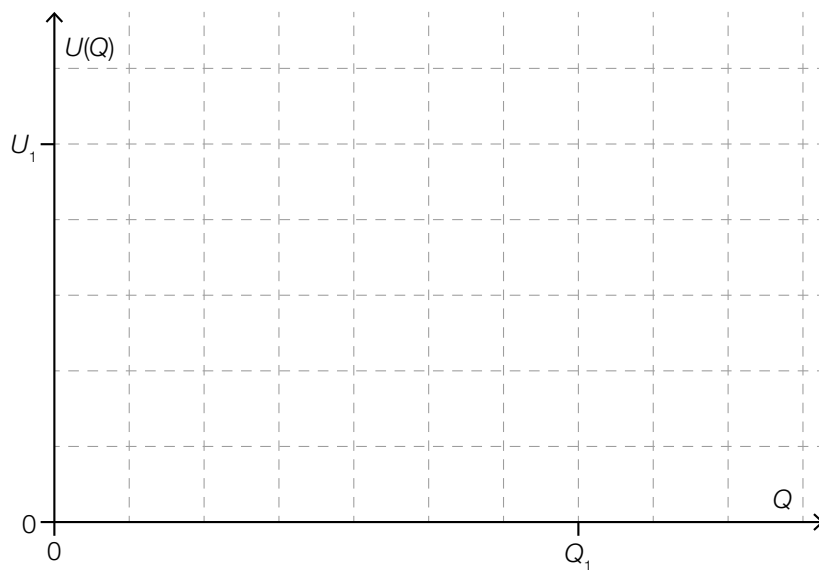

The energy  $W$  that is stored inside the capacitor can be calculated using the formula  $W = \int_0^{Q_1} U(Q) dQ$ .

Write down a formula for the energy  $W$  with respect to  $U_1$  and  $C$ .



- b) During the process of charging, the voltage  $U$  between the capacitor plates in terms of the time  $t$  can be described by the equation  $U(t) = U^* \cdot \left(1 - e^{-\frac{t}{\tau}}\right)$ . Here,  $U^* > 0$  is the voltage that is applied to the capacitor and  $\tau > 0$  is the characteristic constant of the charging process. The charging process starts at  $t = 0$ .

The time after which the voltage  $U(t)$  between the capacitor plates reaches 99 % of the applied voltage  $U^*$  is known as the *charging time*.

Determine the charging time of a capacitor with respect to  $\tau$ .

Write down a formula for the instantaneous rate of change of the voltage between the capacitor plates with respect to  $t$  and show on the basis of this formula that the charge is constantly increasing during the charging process.

## Task 3

### Wealth Distribution

The total wealth of a country is often distributed very unevenly across its population. A survey conducted in 2012 by the European Central Bank (ECB) provided data for an estimate of which proportion of the Austrian population owns which share of the wealth (in millions of euros). The results of the study based on this information are shown in Diagram 1. The 20 % threshold, for example, means that the most disadvantaged 20 % of the Austrian population in terms of wealth own assets of € 6,086 at most.

In the year 2012, Austria had a total population of around 8.45 million inhabitants.

The so-called *Lorenz curve L* (see Diagram 2) illustrates which relative proportion of the population owns which relative proportion of the total wealth. Thus, according to the ECB study, the most disadvantaged 80 % in terms of wealth own only around 23 % of the total wealth.

Diagram 1:

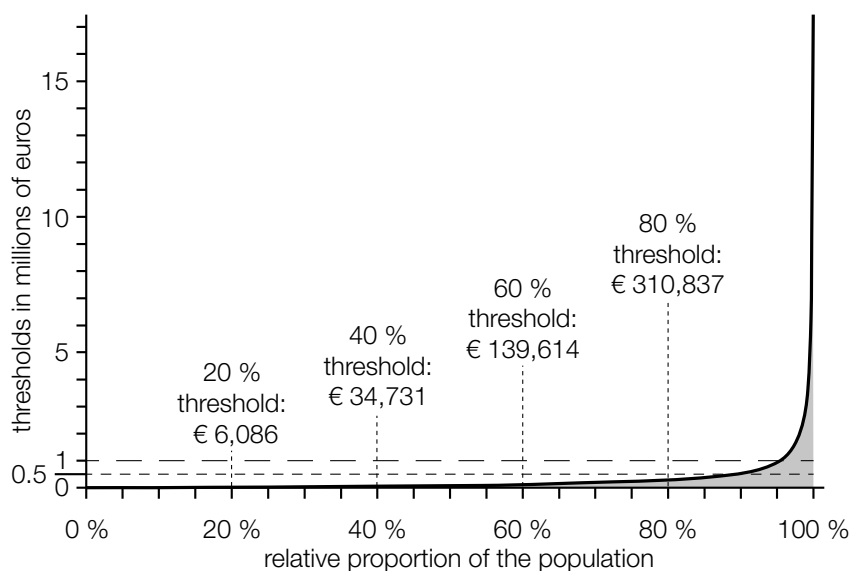
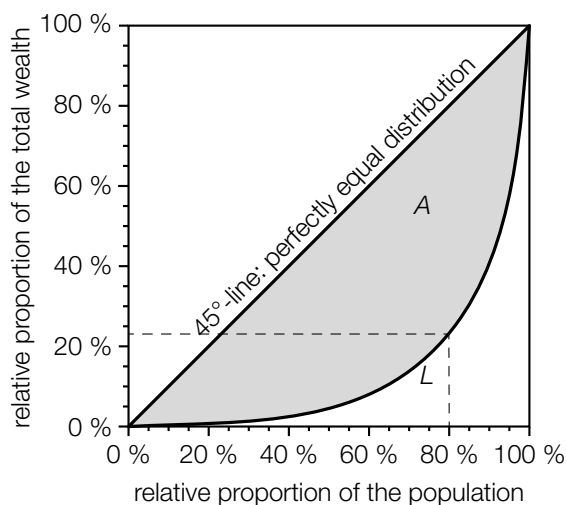

Diagram 2:



The Gini coefficient is a measure of the inequality of a country's distribution of wealth. It equals the quotient of the area of the shaded region  $A$  (between the  $45^\circ$ -line and the Lorenz curve  $L$ ) and the area of the triangle defined by the given points  $(0 \%, 0 \%)$ ,  $(100 \%, 0 \%)$  and  $(100 \%, 100 \%)$ . According to the ECB study, Austria's Gini coefficient for the year 2012 was 0.76.

Task:

- a)  A Using Diagram 1, determine how many Austrian people owned assets worth at least one million euros in 2012.

Under the simplified assumption that the thresholds in the interval  $[20 \%, 40 \%]$  can be expressed as a linear function, determine an approximation of the 25 % threshold.

- b) Determine the relative proportion of wealth that is owned by the wealthiest 10 % of the Austrian population.

According to a study carried out by the University of Linz in 2013, the relative proportion of the total wealth owned by the wealthiest 10 % of the Austrian population was much higher than the ECB study claimed.

Considering the results of the study by the University of Linz, a different Lorenz curve  $L^*$  than the shown Lorenz curve  $L$  is obtained. Sketch one possible shape of a Lorenz curve  $L^*$  that shows this results in the diagram below.

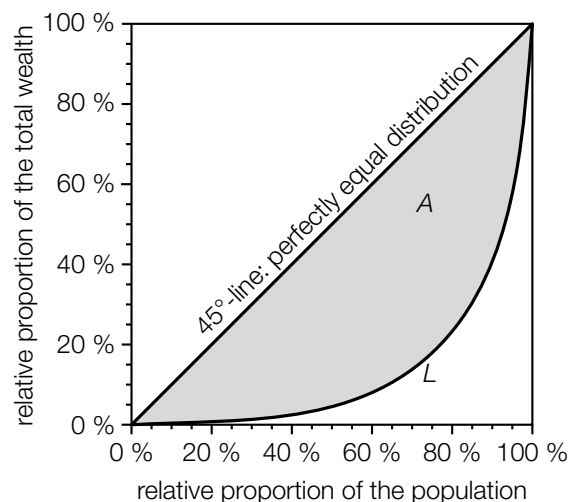

- c) The Lorenz curve in the interval  $[0, 1]$  can be modelled by a real function in terms of  $x$ , where  $x$  stands for the relative proportion of the population.

Determine the Gini coefficient for a country  $S$ , whose Lorenz curve for the year 2012 can be described by the function  $L_1$  with equation  $L_1(x) = 0.9 \cdot x^5 + 0.08 \cdot x^2 + 0.02 \cdot x$  in the interval  $[0, 1]$ .

Compare your result with the Austrian Gini coefficient for the year 2012 and determine whether the total wealth in this year was more equally distributed among the population of Austria or country  $S$ .

## Task 4

### Election Forecast

There are different mathematical methods used to forecast how voters behave in upcoming elections. One popular method is to collect and analyse data from a sample. Another method is to calculate so-called *regression lines* which enable a relatively precise forecast. To determine such regression lines, the results of a so-called *comparable election* are used, ideally of one that has taken place shortly before the election.

4 150 eligible voters of a particular village, consisting of five constituencies, could decide between two candidates, *A* and *B*, in a mayoral election. All voters cast their vote and there were no invalid votes. After having counted all the votes from four of the five constituencies, the following interim results were obtained:

Table 1: Mayoral election

	1 <sup>st</sup> Constituency	2 <sup>nd</sup> Constituency	3 <sup>rd</sup> Constituency	4 <sup>th</sup> Constituency	5 <sup>th</sup> Constituency
Candidate <i>A</i>	443	400	462	343	not counted
Candidate <i>B</i>	332	499	466	227	not counted
Eligible Voters	775	899	928	570	978

The relative proportion of votes for candidate *A* in the first four constituencies for the mayoral election is denoted by  $h$ .

#### Task:

- a)  A Determine how many votes for candidate *A* can be expected in the 5<sup>th</sup> Constituency, if  $h$  is taken as the estimate for the relative proportion of votes for this candidate in this particular constituency.

In the 4<sup>th</sup> Constituency, the result for candidate *A* deviates most strongly from  $h$ . Write down how much these values differ in terms of percentage points.

- b) The following table shows the results of a comparable election.

Table 2: Comparable election

	1 <sup>st</sup> Constituency	2 <sup>nd</sup> Constituency	3 <sup>rd</sup> Constituency	4 <sup>th</sup> Constituency	5 <sup>th</sup> Constituency	Total
Candidate A	390	416	409	383	478	2076
Candidate B	385	483	519	187	500	2074
Eligible Voters	775	899	928	570	978	4150

Let  $x$  be the number of votes for candidate A in the comparable election and  $y$  be the number of votes for candidate A in the mayoral election. Thus, the results of candidate A from the 1<sup>st</sup>, 2<sup>nd</sup>, 3<sup>rd</sup> and 4<sup>th</sup> Constituency define four points in a Cartesian coordinate system. The regression line  $g: y = 1.5462 \cdot x - 205.71$  goes through this "point cloud" in a way that a linear relationship between the two variables  $x$  and  $y$  is well-described.

Using this regression line  $g$ , determine the expected number of votes for candidate A in the mayoral election in the 5<sup>th</sup> Constituency.

Interpret the gradient of the regression line  $g$  in the given context.

- c) In an Austrian-wide election, a third candidate C can be chosen. Based on an earlier election, it is known that the proportion of votes  $h$  for candidate A in the constituencies 1 to 4 of the mayoral election is representative for the proportion of votes for candidate C in the Austrian-wide election.

Using the proportion of votes  $h$ , determine a symmetrical 95 % confidence interval for the unknown proportion of votes for candidate C.

After all votes have been counted, candidate C received 61 % of all the votes in the Austrian-wide election. Thus, this proportion of votes lies outside the symmetrical 95 % confidence interval determined above.

If a confidence level of 90 % had been chosen, the width of the confidence interval obtained would have been different.

State whether the actual proportion of votes for candidate C would be included in this confidence interval and justify your decision.

## Task 1

### Quadratic Function

This task deals with quadratic functions of the form  $x \mapsto a \cdot x^2 + b \cdot x + c$  where  $a, b, c \in \mathbb{R}$  and  $a \neq 0$ . The choice of the coefficients  $a$ ,  $b$  and  $c$  influences various properties of the function such as the sign of the function, changes in sign, symmetry about the axes and points of intersection with the axes.

Task:

- a) The graph of a quadratic function  $f$  is symmetric about the vertical axis and crosses the  $x$ -axis at  $x_1$  and  $x_2$  with  $x_1 < x_2$ . For  $f$ , the expression  $\int_{x_1}^{x_2} f(x) dx = d$  where  $d \in \mathbb{R}^+$  holds.

Sketch an appropriate graph of a function  $f$  in the coordinate system given below that shows the value  $d$ .

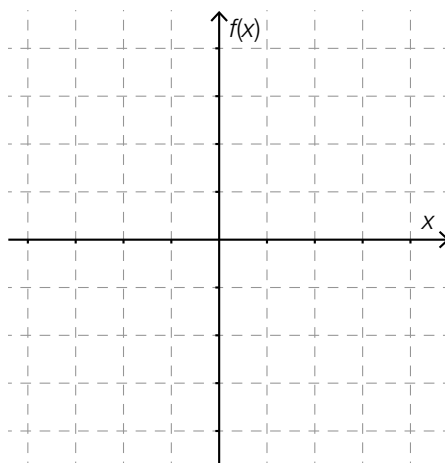

For each of the coefficients  $a$ ,  $b$  and  $c$  of the function  $f$ , write down whether the coefficient must be positive, negative or exactly zero.

- b) The graph of a quadratic function  $g$  has a minimum and crosses the  $x$ -axis at  $x_1 = 0$  and  $x_2 > 0$ . The zero  $x_2$  can be calculated by using the coefficients of the function  $g$ . Write down an appropriate formula.

The graph of the function  $g$  creates an area bounded by the curve and the  $x$ -axis. Write down a definite integral that can be used to calculate the size of this finite area.

- c) For the point where  $x = k$  ( $k \in \mathbb{R}$ ) of the graph of a quadratic function  $h$ , the conditions  $h(k) = 0$  and  $h'(k) = 0$  hold.

A Sketch a possible graph of  $h$  and mark where  $x = k$  in the coordinate system below.

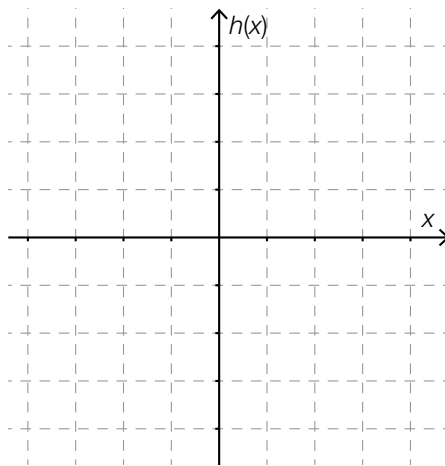

Show by calculation that a function  $h$  with equation  $h(x) = x^2 - 2 \cdot k \cdot x + k^2$  satisfies the conditions  $h(k) = 0$  and  $h'(k) = 0$ .

## Task 2

### Muscular Strength

The behaviour of muscles is often compared to that of (metal) springs. However, unlike elastic force, muscular strength also depends on the velocity with which the muscle contracts (i. e. actively shortens or tenses).

This relationship can be modelled by the formula  $F = \frac{c}{v + b} - a$ .

In this formula,  $F$  gives the possible strength (in newtons) of the muscular force under ideal conditions with a particular contraction velocity  $v$  (in metres per second). The parameters  $a$  (in N),  $b$  (in m/s) and  $c$  (in watts) are positive real quantities that describe properties of the muscle.

The formula given above can be considered as the equation of a function  $F$  that describes the muscular strength,  $F(v)$ , in terms of the velocity of the muscular contraction,  $v$ . The values of  $a$ ,  $b$  and  $c$  are constant for a particular muscle.

The graph of the function  $F$  is shown in the diagram below.

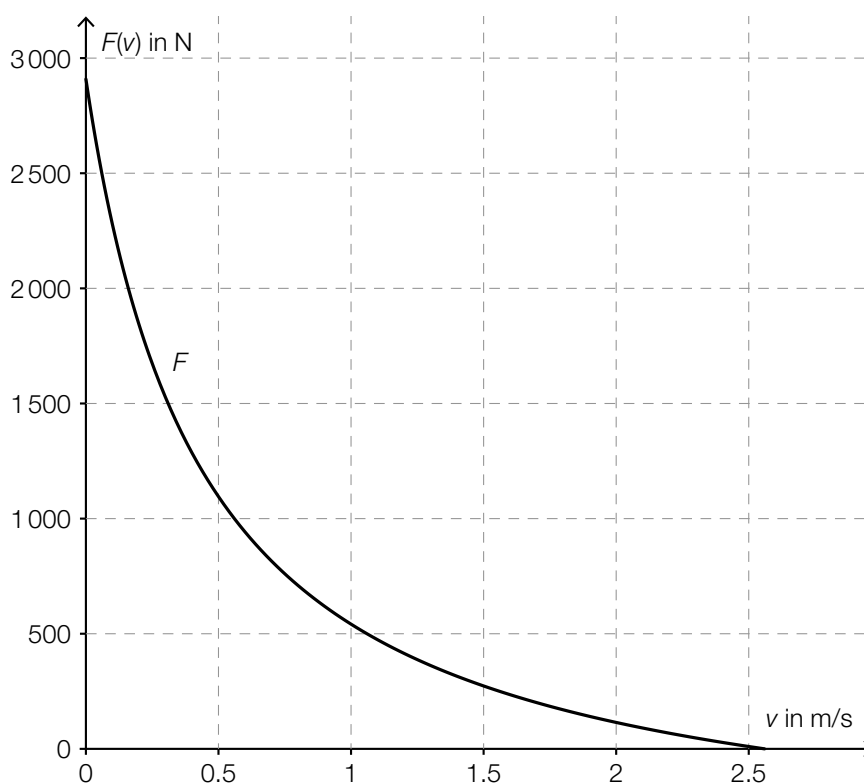



Task:

- a) From the diagram, write down the value  $F(0)$  and how this value should be interpreted in the given context.

Write down whether the function  $F$  describes an indirectly proportional relationship between  $F$  and  $v$  and justify your answer.

- b) The power of a muscle can be determined by the formula  $P = F \cdot v$ .

Given a constant force,  $F$ , this formula can be considered as the equation of a function  $P$  in which the power,  $P(v)$ , is described in terms of the velocity of the muscle contraction,  $v$  ( $P(v)$  in W,  $v$  in m/s and  $F$  in N).

In the diagram below, the graphs of the functions  $F$  and  $P$  are shown in terms of the velocity of the muscle contraction,  $v$ , for a particular muscle.

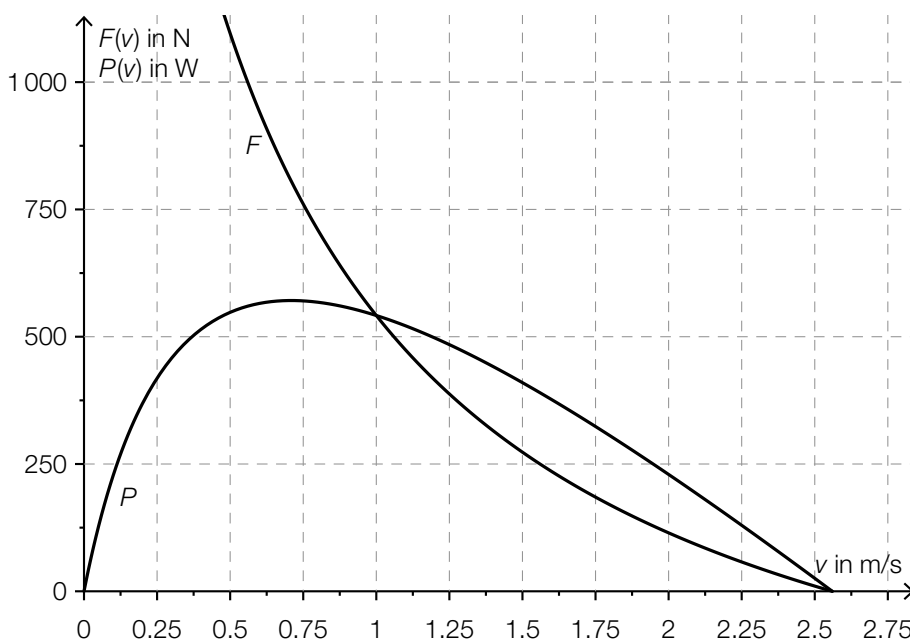

- A From the diagram, determine an approximate value for the strength (in N) that gives the maximum power for this muscle.

From the diagram, determine an approximate value of the velocity of the muscle contraction  $v_1$  for which  $P'(v_1) = 0$  holds.

## Task 3

### Destruction of the Rainforest

Various studies are concerned with the destruction of the rainforest.

In 1992, a team led by the American economist Dennis Meadows published the study *Beyond the Limits*.

In this study, the rainforest coverage of the Earth at the end of 1990 was determined to be 800 million hectares. In the following year, around 17 million hectares was cleared. The three "catastrophe scenarios" listed below were suggested by the study:

Scenario 1: The annual relative reduction of approximately 2.1 % remains constant.

Scenario 2: The deforestation of 17 million hectares per year remains constant.

Scenario 3: The rate of deforestation (in millions of hectares per year) increases exponentially.

Diagram 1 below shows the graphs of the functions  $f_1$  and  $f_3$ , which describe the rainforest coverage according to scenarios 1 and 3 as described above.

Diagram 2 below shows the graph of the first derivative  $f_3'$  of the function  $f_3$  shown in diagram 1.

Diagram 1:

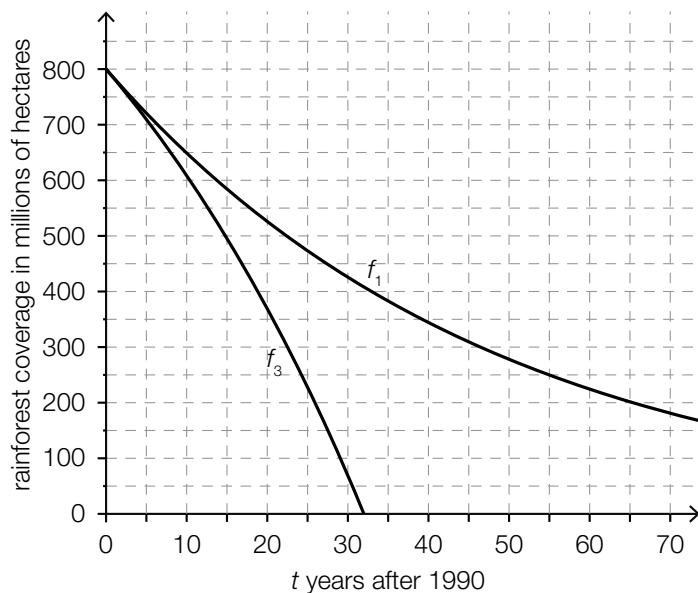
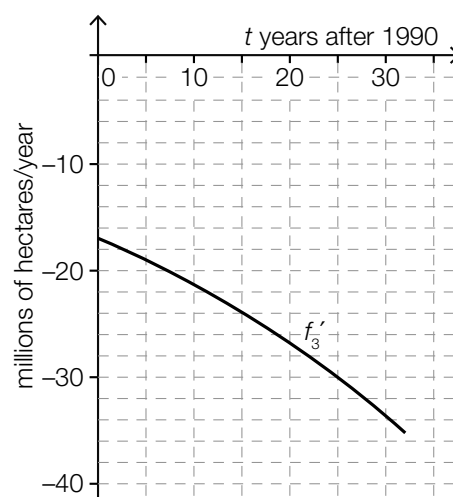

Diagram 2:



Task:

- a)  A Determine the equation of the function  $f_1$  in which the variable  $t$  corresponds to the years passed since after 1990.

Determine when the rainforest coverage will have sunk to below 100 million hectares according to scenario 1.

- b) Write down the equation of the function  $f_2$  that models the rainforest coverage  $t$  years after 1990 assuming that the coverage will reduce by a constant amount of 17 million hectares per year.

Determine in which year the rainforest would disappear from the Earth's surface according to this model and draw the graph of this function on diagram 1.

- c) In the following sub-tasks, you should base your solutions on Meadow's assumption of an exponentially increasing rate of deforestation and give your answers based on the corresponding diagrams.

Write down an approximate value for the time  $t_1$  at which the instantaneous rate of deforestation has reached 24 million hectares per year.

Determine an approximate value for the definite integral  $\int_0^{t_1} f_3'(t) dt$  by reading from the graph and write down the meaning of this result in the context of the deforestation of the rainforest.

- d) An international research team led by geographer Matthew Hansen from the University of Maryland determined the change in the number of trees in the rainforest from 2000 to 2012 by using satellite photos. From the data, it can be established that, on average, each year  $a$  million hectares ( $a > 0$ ) more are deforested each year than in the previous year.

Justify why scenario 3 as suggested by Meadows best corresponds to Matthew Hansen's observations.

Hansen's team reports 0.2101 million hectares per year for the value  $a$ . Write down whether Meadow's model predicting the rate of change of deforestation for the time period from 2000 to 2012 is larger or smaller than the values observed by Hansen and justify your answer.

## Task 4

### Buccolam

Buccolam is a liquid pharmaceutical used in the treatment of acute, persistent cases of seizures in people who are at least three months old and younger than 18 years old (hereafter referred to as “children”). It contains the active ingredient midazolam, a highly effective sedative.

In the course of a clinical trial, Buccolam is administered to 440 children with seizures. 22 of the children experienced side effects of nausea and vomiting. In 308 of the children, visible signs of seizure disappeared within 10 minutes of taking the medication.

#### Task:

- a) There are four types of Buccolam injections that contain appropriate doses of midazolam for children of different ages:

Age Range	Midazolam Dose	Label Colour
up to < 1 year	2.5 mg	yellow
1 year up to < 5 years	5 mg	blue
5 years up to < 10 years	7.5 mg	purple
10 years up to < 18 years	10 mg	orange

*Data source: [http://www.ema.europa.eu/docs/de\\_DE/document\\_library/EPAR\\_-\\_Product\\_Information/human/002267/WC500112310.pdf](http://www.ema.europa.eu/docs/de_DE/document_library/EPAR_-_Product_Information/human/002267/WC500112310.pdf) [02.12.2016].*

These injections each contain a solution with an age-appropriate midazolam dose. For example, the injections with a yellow label contain a solution with a volume of 0.5 ml. In general, the volume  $V$  (in ml) of a solution and the midazolam dose  $D$  (in mg) are directly proportional.

Write down an equation that describes the relationship between the volume of a solution,  $V$ , and the midazolam dose,  $D$ .

Write down whether the relationship between the patient's age (in years) and the midazolam dose is linear. Justify your answer based on the data provided in the table above.

- b) The relative frequency  $H$  of side effects after administering a medication is classified as follows:

common	$0.01 \leq H < 0.1$
uncommon	$0.001 \leq H < 0.01$
rare	$0.0001 \leq H < 0.001$
very rare	$H < 0.0001$

Data source: <https://www.vfa.de/de/patienten/patientenratgeber/ratgeber031.html> [02.12.2016] (adapted).

- A** Write down how the relative frequency of the side effect “nausea and vomiting” of Buccolam should be classified according to the clinical trial described in the introduction.

In the information about Buccolam included with the medication, the frequency of experiencing a “skin rash” is given as “uncommon”.

The random variable  $X$  describes how many of the 440 children treated with Buccolam during the course of the trial experienced the side effect of a “skin rash”. This random variable can be taken to be a binomially distributed random variable with parameter  $p = 0.01$ , expectation value  $\mu$ , and standard deviation  $\sigma$ .

Write down how many children in the trial could have experienced the side effect of a “skin rash” so that the number of children affected lies in the interval  $[\mu - \sigma; \mu + \sigma]$ .

- c) The actual proportion of patients whose visible signs of seizure disappear within 10 minutes after consuming the medication is given by  $p$ .

Using the data provided in the introduction about the clinical trial, determine a symmetrical confidence interval for  $p$  with confidence level  $\gamma = 0.95$ .

In a separate trial investigating the efficacy of Buccolam,  $n_1$  children were involved. Using the same method, the results led to the symmetrical confidence interval  $[0.67, 0.73]$  with confidence level  $\gamma_1$ .

Justify why the values  $n_1 < 400$  and  $\gamma_1 = 0.99$  could not have been the basis for calculating this confidence interval.

# Task 1

## Radioactivity and Carbon Dating

When a radioactive substance decays, the number of nuclei still to decay decreases exponentially and can be approximated by the function  $N$  where  $N(t) = N_0 \cdot e^{-\lambda \cdot t}$ . In this function,  $N_0$  is the number of atomic nuclei at time  $t = 0$ ,  $N(t)$  gives the number of nuclei still to decay at time  $t \geq 0$ , and  $\lambda$  is the so-called decay constant.

The activity,  $A(t)$ , is given by the absolute value of the instantaneous rate of change of the function  $N$  at time  $t$ . It is measured in Becquerels (Bq). An activity of 1 Bq corresponds to one decay per second.

For radioactive substances, the activity also decreases exponentially and can be modelled by a function  $A$ , where  $A(t) = A_0 \cdot e^{-\lambda \cdot t}$ . In this function,  $A_0$  gives the activity at time  $t = 0$  and  $A(t)$  gives the activity at time  $t \geq 0$ .

### Task:

- a) Write down a formula using which the original number of atomic nuclei,  $N_0$ , can be calculated from the observed activity,  $A_0$ .

A sample of  $^{238}\text{U}$  (uranium 238) has an activity of 17 Bq at time  $t = 0$ . The decay constant of  $^{238}\text{U}$  is  $\lambda \approx 4.92 \cdot 10^{-18}$  per second.

Determine the number of  $^{238}\text{U}$  nuclei in the sample at time  $t = 0$ .

- b) Using the amount of the carbon isotope  $^{14}\text{C}$  contained in a sample, the age of the sample can be determined. Due to the metabolic process, an equilibrium concentration of  $^{14}\text{C}$  and/or an activity of about 0.267 Bq per gram of carbon had adjusted between the formation and the decay of the isotope, in the atmosphere as well as in living organisms. With the dying of an organism (e.g. a tree), the absorption of  $^{14}\text{C}$  ends. The  $^{14}\text{C}$ -amount decreases from this point of time exponentially (with a decay constant of  $\lambda \approx 1.21 \cdot 10^{-4}$  per year) and with it, the activity also begins to decrease exponentially.

A wooden artefact contains 25 grams of carbon and has an activity of around 4 Bq. Determine how many years ago this wood has died.

Determine whether more or fewer than half of the original number of  $^{14}\text{C}$  atoms had decayed by the time the artefact was found and justify your answer.

c) The function  $N$  can also be written in the form  $N(t) = N_0 \cdot 0.5^{\frac{t}{c}}$ , where  $c \in \mathbb{R}^+$ .

**A** Determine the relationship between the constant  $c$  and the half-life of a radioactive substance,  $\tau$ .

In the diagram below, the graph of a function  $N$  is shown, where  $N(t) = N_0 \cdot 0.5^{\frac{t}{c}}$  with  $c \in \mathbb{R}^+$ .

On this diagram, draw the graph of a function  $N_{\text{new}}$ , where  $N_{\text{new}}(t) = N_0 \cdot 0.5^{\frac{t}{c_{\text{new}}}}$  with  $c_{\text{new}} \in \mathbb{R}^+$  given that  $c_{\text{new}} < c$ .

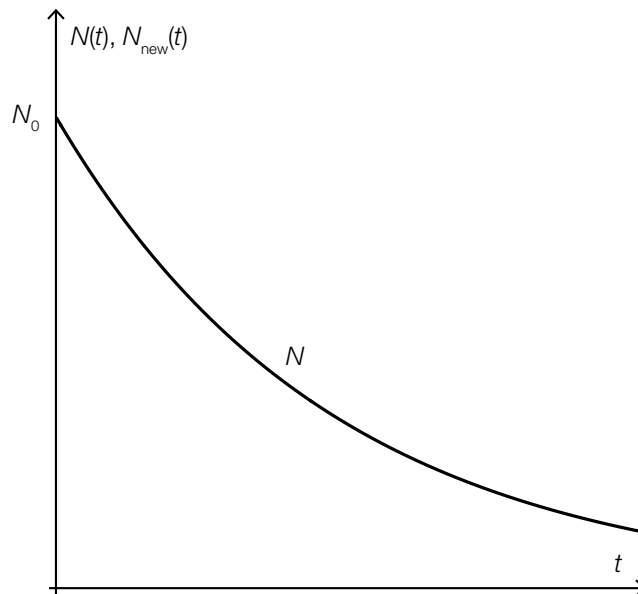

## Task 2

### Swimming Zones

Due to the large number of motorboats, jet-skis etc., some beaches have introduced swimming zones.

All of the swimming zones dealt with in this task are created using two buoys and a 180 meter-long rope that is attached to a beach. The beach can be approximated by a straight line.

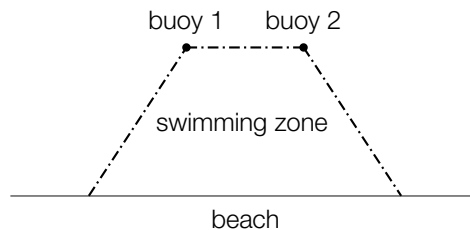

Task:

- a) A rectangular swimming zone is shown below ( $x$  is measured in metres).



A Show that the equation the area  $A(x)$  of this type of swimming zone can be given by  $A(x) = 180 \cdot x - 2 \cdot x^2$ .

Determine the length, the width and the area of the swimming zone that has the largest possible area.

Length = \_\_\_\_\_ m

Width = \_\_\_\_\_ m

Area = \_\_\_\_\_ m<sup>2</sup>

- b) A swimming zone in the shape of a trapezium is shown below ( $x$  and  $h$  are measured in metres).

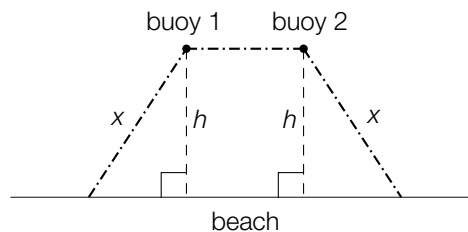

In order to calculate the area of a trapezium-shaped swimming zone, the following formula can be used:  $A(x, h) = h \cdot (180 - 2 \cdot x + \sqrt{x^2 - h^2})$ .

Determine the possible values of  $x$  when  $h$  is 40 m long.

Determine the possible values of  $h$  when  $x$  is 50 m long.



- c) A swimming zone in the shape of a trapezium is shown below in which the three sections of rope are the same length ( $x$  and  $h$  are measured in metres).

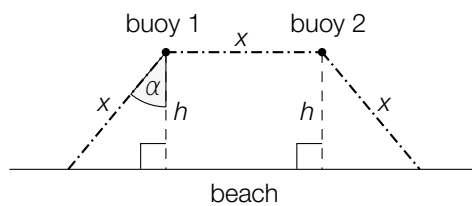

The area of a swimming zone of this type,  $A(\alpha)$ , can be described as a function of the angle  $\alpha$  (where  $A(\alpha)$  is measured in  $\text{m}^2$  and  $\alpha$  is measured in degrees).

Write down a formula that can be used to calculate the area of such a swimming zone given the angle  $\alpha$ .

$A(\alpha) =$  \_\_\_\_\_

In the diagram below, the values of the areas for various angles  $\alpha$  are shown.

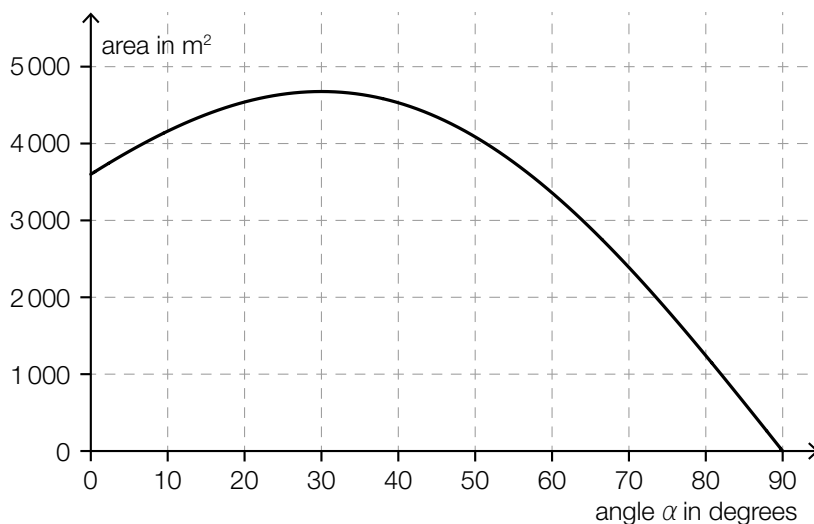

A swimming zone with the largest possible area is to be constructed. Using the diagram above, determine the length of the section of the beach from which the swimming zone with the largest possible area can be accessed.

## Task 3

### Brazil

Brazil is the largest and most populous country in South America.

In 2014, Brazil had 202.74 million inhabitants.

From censuses, the following inhabitant data is known:

Year	Number of Inhabitants
1970	94 508 583
1980	121 150 573
1991	146 917 459
2000	169 590 693
2010	190 755 799

Task:

- a)  Write down the meaning of the values shown below in the context of the development of the number of inhabitants.

$$\sqrt[10]{\frac{121\,150\,573}{94\,508\,583}} \approx 1.02515$$

$$\sqrt[9]{\frac{169\,590\,693}{146\,917\,459}} \approx 1.01607$$

Using the values shown, justify why the development of the number of inhabitants within the complete time period between 1970 and 2010 cannot suitably be described by an exponential function.

- b) Assuming that the trend follows linear growth, use the values for the numbers of inhabitants in 1991 and 2010 to write down a function  $f$  that describes the number of inhabitants. In this function, the time  $t$  is measured in years and the time  $t = 0$  corresponds to the year 1991.

Determine the percentage by which the prediction given by the linear model for 2014 deviates from the actual value given in the introduction.

- c) For the time period from 2010 to 2015, there was a constant birth rate of  $b = 14.6$  and a constant death rate of  $d = 6.6$  in Brazil. These figures mean that there were 14.6 births per 1 000 inhabitants and 6.6 deaths per 1 000 inhabitants per year.

The development of the number of inhabitants can be described by the difference equation  $x_{n+1} = x_n + x_n \cdot \frac{1}{1000} \cdot (b - d) + m_n$ , where  $x_n$  gives the number of inhabitants in year  $n$  and  $m_n$  gives the difference between the number of immigrants and emigrants. This difference is known as the net migration.

Write down the meaning of the expression  $x_n \cdot \frac{1}{1000} \cdot (b - d)$  in the context of the development of the number of inhabitants.

Determine the largest possible value for net migration if the number of inhabitants in 2015 in comparison to the previous year has increased by a maximum of 1 %.

## Task 4

### Children's Growth

In order to monitor the development of a child's height and mass, the percentile curves for height (in cm) and mass (in kg) are provided in the baby's 'Developmental Record Book'. Percentiles split the heights and masses of children into percentage-areas. If a value lies on the 10<sup>th</sup> percentile curve for height, this means that 10 % of children at this age are shorter than or the same height as this value, and 90 % are taller than or the same height as this value.

It is common to describe all values between the 3<sup>rd</sup> and 97<sup>th</sup> percentiles as "normal". The following diagram shows the height and body mass curves for boys aged between 0 and 18 years:

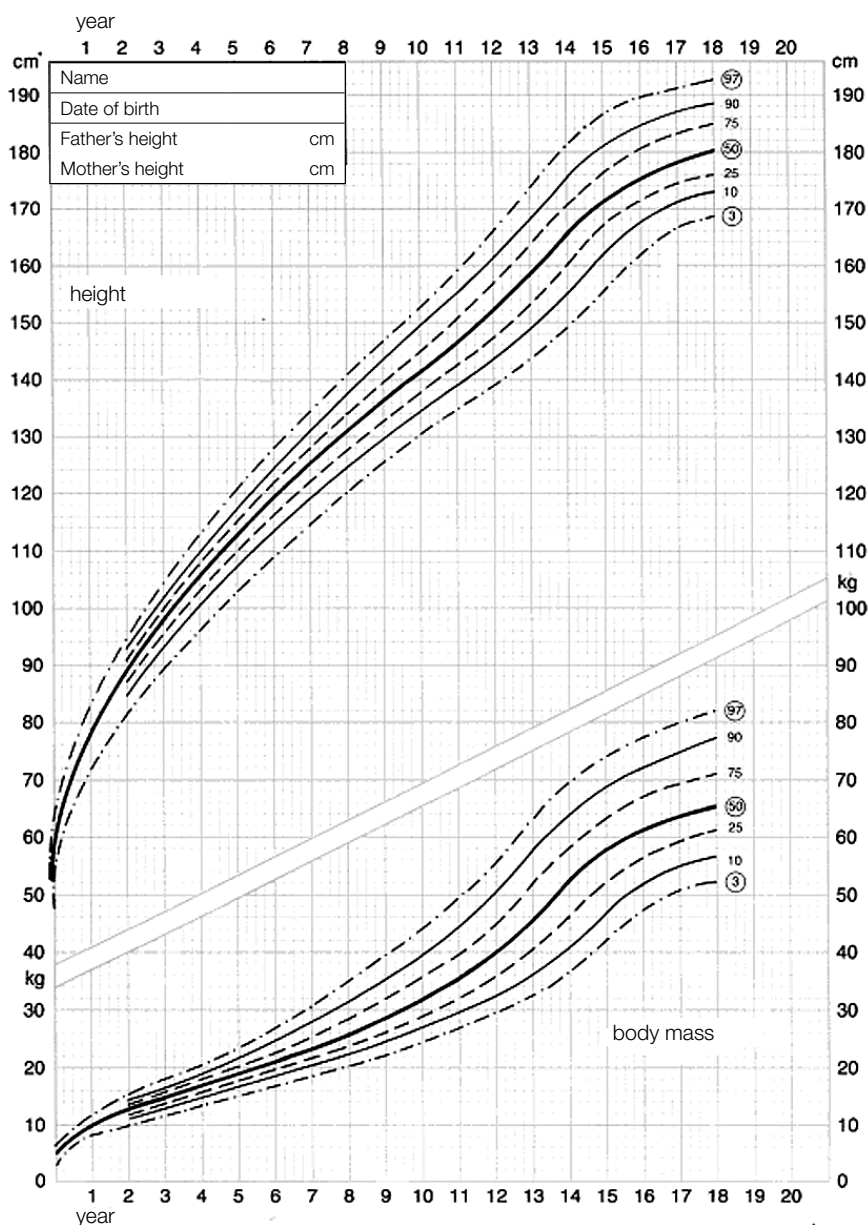

Task:

- a) A school doctor is examining a random sample of 8 year-old boys from his district and records, among other things, their masses (in kg). Using the results of these measurements, he constructs the symmetrical confidence interval  $[0.8535, 0.9465]$  with confidence level  $\gamma = 0.95$  for the proportion of 8 year-old boys from his district whose mass lies in the “normal range” of  $[20 \text{ kg}, 35 \text{ kg}]$ .

Determine the difference in percentage points between the proportion of the sample with a body mass in the “normal range” according to the calculation and the proportion of all 8 year-old boys with a body mass in the “normal range” according to the diagram.

Determine the number of 8 year-old boys that were included in this random sample.

- b) The height of a particular child on their first, second, third (etc.) birthday is given by  $g(1), g(2), g(3), \dots$  respectively. Write down either in words or as a formula, how the average rate of growth of this child in the three year period between its 6<sup>th</sup> and 9<sup>th</sup> birthday can be determined.

Consider the growth curve for the 50<sup>th</sup> percentile after a child's 8<sup>th</sup> birthday. Determine the approximate age at which the instantaneous speed of growth is the highest.

- c)  A State which statistical value can be read from the 50<sup>th</sup> percentile.

Describe the difficulties that would arise if you were to attempt to construct a box plot to represent the heights of 8 year-old boys from the diagram given.

## Task 1

### Function

Let  $f$  be a quadratic function where  $f(x) = a \cdot x^2 + b \cdot x + c$  with coefficients  $a, b, c \in \mathbb{R}$ .

Task:

- a) Determine the coordinates of the point  $P$  on the graph of one such function  $f$  at which the gradient of the tangent to the graph of the function  $f$  has the value  $b$  and, furthermore, write down a general equation of this tangent  $t$ .

The graph of one such function  $f$  goes through the point  $A = (-1, 20)$  and has a tangent  $t$  where  $t(x) = 9 \cdot x + 4$  at point  $P$ . For this function  $f$ , write down the values of  $a, b$  and  $c$ .

- b) Write down an expression that gives  $a$  in terms of  $b$  and  $c$  such that the function  $f$  has exactly one zero.

In the coordinate system provided below, sketch a possible graph of one such function  $f$  with exactly one zero and  $a > 0, b > 0, c > 0$ .

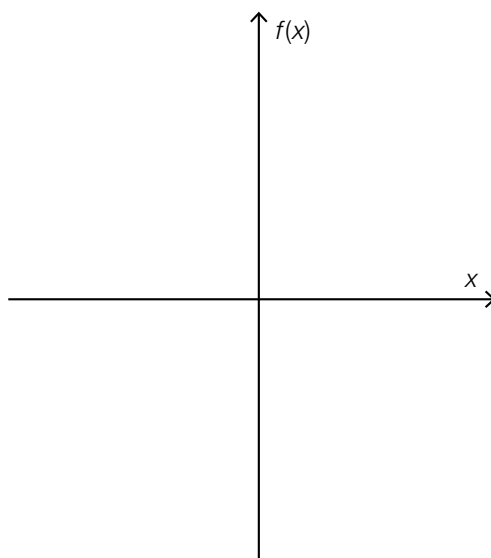

- c)  A For  $a = 16$  and  $c = 9$ , write down both the position of the local maximum or minimum of the function  $f$  as well as the corresponding value of the function at this point in terms of  $b$ .

Show that this maximum or minimum lies on the graph of the function  $g$  where  $g(x) = 9 - 16 \cdot x^2$  regardless of the value chosen for  $b$ .

## Task 2

### Road with an Incline

A car travels on a straight section of road that has an incline. Over a certain time period, the car covers the distance between points  $A$  and  $B$ . The height of the section of road between  $A$  and  $B$  above the height of point  $A$  can be modelled by a polynomial function  $h$  in terms of  $x$ . Here,  $x$  corresponds to the horizontal distance of the car (which is here modelled as a point) from the point  $A$  and  $h(x)$  gives the height of the position of the car above the height of point  $A$  ( $h(x)$  in m,  $x$  in m). In this model, the points  $A$  and  $B$  have coordinates  $A = (0,0)$  and  $B = (60,10)$ .

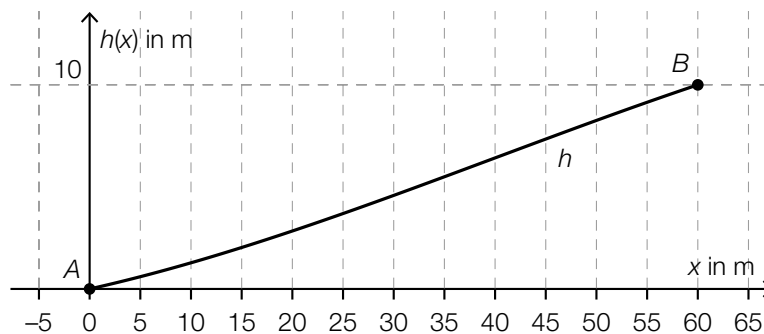

An equation of the function  $h$  is:

$$h(x) = \frac{1}{64800} \cdot (-x^3 + 120 \cdot x^2 + 7200 \cdot x) \text{ for } x \in [0, 60]$$

Task:

- a) Write down the value of the difference quotient of the function  $h$  in the interval  $[0, 60]$  and interpret this value in the given context.

A person claims: "If any section of road that has an incline can be modelled by a third degree polynomial function whose point of inflexion lies within this section, then the point of inflexion represents the point at which the incline of the road is the steepest."

Write down whether this claim is definitely true and justify your decision.

- b) There are plans to rebuild the road in such a way that the section between  $A$  and  $B$  has a constant gradient.

Determine the equation of the function  $h_1$  that gives the shape of the new road between  $A$  and  $B$ . For this function,  $h_1(x)$  should give the height (in m) of the position of the car above the height of point  $A$ .

Determine the size of the angle  $\alpha$  that gives the incline of the new road (as measured from the horizontal).

- c) When driving in the mountains, there is an uncomfortable pressure on the eardrum that many people describe as an “attack” on the ears. This pressure occurs to a person within a car if the instantaneous rate of change of the height exceeds a value of 4 m/s.

The function  $g$  where  $g(t) = \frac{1}{5} \cdot t^2 + t$  models the position of the car above the height of  $A$  during the journey from  $A = (0,0)$  to  $B = (60,10)$  as a function of time. The function  $g(t)$  gives the height of the car at time  $t$  ( $g(t)$  in metres,  $t$  in seconds measured from the time at which the car is at point  $A$ ).

Determine how many seconds the car takes to travel from  $A$  to  $B$ .

Write down whether the instantaneous rate of change of the height during this time period exceeds a value of 4 m/s and justify your answer.



## Task 3

### Human Development Index

The Human Development Index (*HDI*) is a welfare indicator of countries calculated by the United Nations that should provide a measurement of the development level of a particular country. The *HDI* uses three dimensionless quantities (Life Expectancy Index (*LEI*), Education Index (*EI*) and Income Index (*I*)) and is calculated using the formula  $HDI = \sqrt[3]{LEI \cdot EI \cdot I}$ . A quantity is dimensionless if it has no units.

Since 2010, the *LEI* and *I* indices have been calculated as follows:

$$LEI = \frac{LE - 20}{85 - 20} \text{ where } LE \text{ is the life expectancy at the time of birth in years}$$

$$I = \frac{\ln(B) - \ln(100)}{\ln(75\,000) - \ln(100)} \text{ where } B \text{ is the gross national income per head in US dollars (always at the beginning of the year)}$$

Since 2009, the development programme of the United Nations has organised countries into four development categories according to the value of the *HDI*:

Development category of a country	Value of the <i>HDI</i>
$E_1$	$\geq 0.8$
$E_2$	$[0.7, 0.8)$
$E_3$	$[0.55, 0.7)$
$E_4$	$< 0.55$

Data source: Deutsche Gesellschaft für die Vereinten Nationen (ed.): *Bericht über die menschliche Entwicklung 2015. Arbeit und menschliche Entwicklung*. Berlin: Berliner Wissenschafts-Verlag 2015, p. 240.

The *HDI* of a region in a particular year is calculated by taking the mean of the *HDI*s of all countries in that region.

The diagram below shows the development of the *HDI* of different regions between 1980 and 2011.

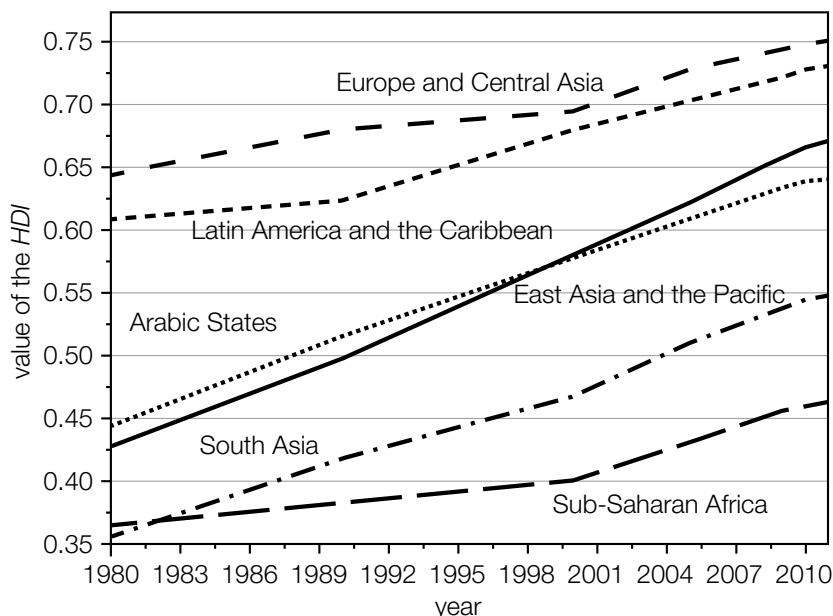

Data source: [https://de.wikipedia.org/wiki/Index\\_der\\_menschlichen\\_Entwicklung#/media/File:Human-Development-Index-Trends-2011.svg](https://de.wikipedia.org/wiki/Index_der_menschlichen_Entwicklung#/media/File:Human-Development-Index-Trends-2011.svg) [08.06.2017].

Task:

- a) For Austria, the *Human Development Report* in 2013 found the life expectancy to be  $LE = 81.1$  years and the education index to be  $EI = 0.819$ .

The diagram below shows the gross national income per head for Austria in US dollars from 2000 to 2013 (measurements taken at the beginning of the year).

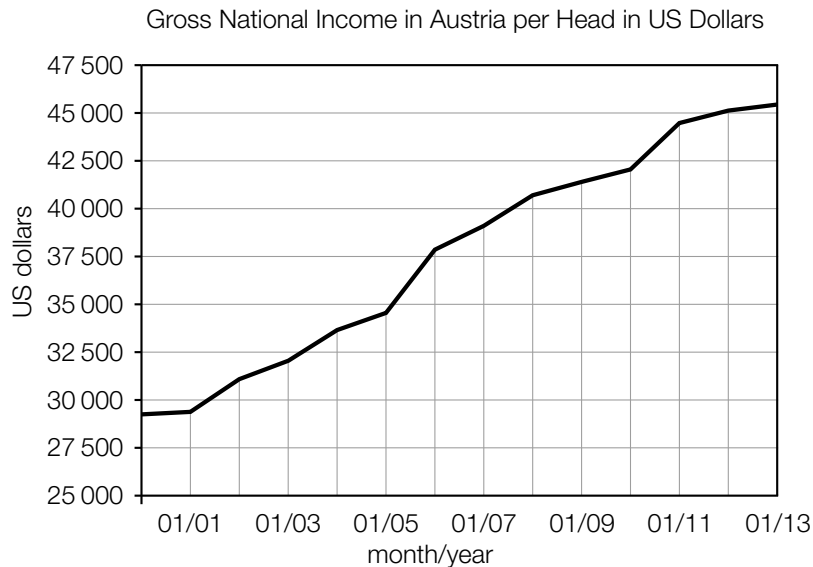

Data source: <http://www.factfish.com/de/statistik/bruttonationaleinkommen> [08.06.2017].

For the year 2013, determine the *HDI* for Austria ( $= HDI_{2013}$ ).

The *HDI* for Austria in the year 2013 ( $HDI_{2013}$ ) was around 2.5 % greater than the *HDI* for Austria in the year 2008 ( $HDI_{2008}$ ). Write down an equation that describes this relationship and calculate the  $HDI_{2008}$ .

- b) The annual trend of the *HDI* for the region of the “Arabic States” from 1980 to 2010 can be approximated by a linear function  $H$  with equation  $H(t) = k \cdot t + d$  where  $k, d \in \mathbb{R}$  and  $t$  measured in years. For this function  $H$ ,  $H(0)$  gives the value in the year 1980.

Determine the value of the parameters  $k$  and  $d$ .

Using the relevant diagram, justify in which region(s) the average annual increase of the *HDI* in the time period from 1980 to 2010 corresponds most closely to the increase seen in the region of the “Arabic States”.

- c)  From the relevant diagram, determine the year at which the region “Latin America and the Caribbean” moved into the development category  $E_2$ .

Is it certain that from this point in time around half of the countries in this region were in the category  $E_2$ ? Justify your answer.

## Task 4

### Density Function and Distribution Function

Let  $X$  be a random variable for which the probability that  $X$  lies in an interval  $I$  can be determined using a so-called density function  $f$  as follows:

$$P(a \leq X \leq b) = \int_a^b f(x) dx \text{ for all } a, b \in I \text{ where } a \leq b$$

The corresponding distribution function  $F$  is given by  $F(x) = P(X \leq x)$  for all  $x \in \mathbb{R}$ .  
Therefore  $F(b) - F(a) = P(a \leq X \leq b)$  for  $a, b \in I$  and  $a \leq b$ .

The diagram below shows the graph of a density function  $f$  with  $f(x) = k \cdot \sin(x)$  for  $x \in [0, c]$ , where  $k \in \mathbb{R}$ ,  $k > 0$  and  $f(c) = 0$  holds. For  $x \notin [0, c]$  then  $f(x) = 0$ .

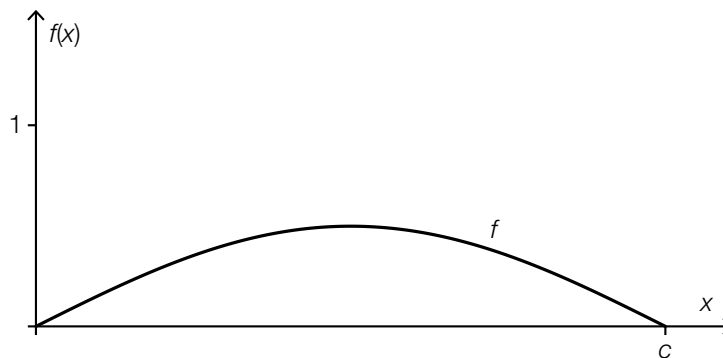

Task:

- a) For the given density function  $f$ , write down the value of the function  $F(0)$  of the corresponding distribution function  $F$  and justify why  $F(c) = 1$ .

$$F(0) = \underline{\hspace{10cm}}$$

On the diagram above, sketch the graph of the corresponding distribution function  $F$  and describe the concavity of  $F$  in the interval  $[0, c]$ .

- b) Write down which property of  $f$  determines the value of the parameter  $k$  and determine the value of  $k$ .

Write down an expression of the corresponding distribution function of  $F$  in the interval  $[0, c]$ .

$$F(x) = \underline{\hspace{10cm}}$$

c) For an event  $E$ ,  $P(E) = 1 - P(X \leq c - a)$  holds for any  $a \in [0, c]$ .

A Describe this event  $E$  in words.

For  $a \leq \frac{c}{2}$ , draw the probability  $P(a \leq X \leq c - a)$  in the diagram below as an area and justify the relationship  $P(a \leq X \leq c - a) = 1 - 2 \cdot P(X \leq a)$  using this representation.

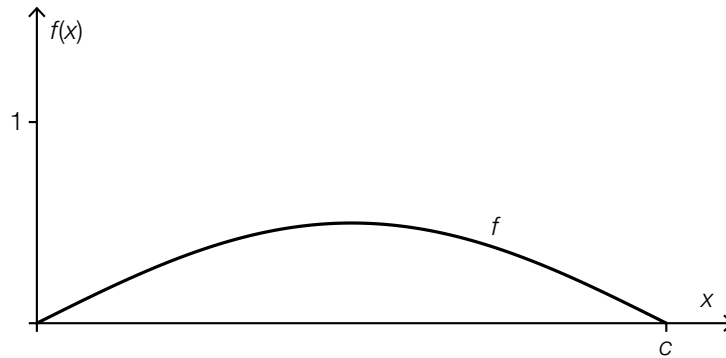

## Task 1

### Intercity-Express (ICE)

The German rail service has a fleet of ICE trains, which is a collection of high speed trains. With a maximum speed of up to 330 km/h (approximately 91.7 m/s) these are Germany's fastest trains. They are approximately 200 metres long and weigh around 400 tonnes. Each train is made up of eight carriages. Trial journeys are carried out for acceleration and braking tests. The results of these tests can be represented graphically.

#### Task:

- a) The data collected during an acceleration test from rest to the maximum speed (where the velocity,  $v_1(t)$ , is measured in metres per second and the time,  $t$ , is measured in seconds) is approximately represented by the velocity-time graph below.

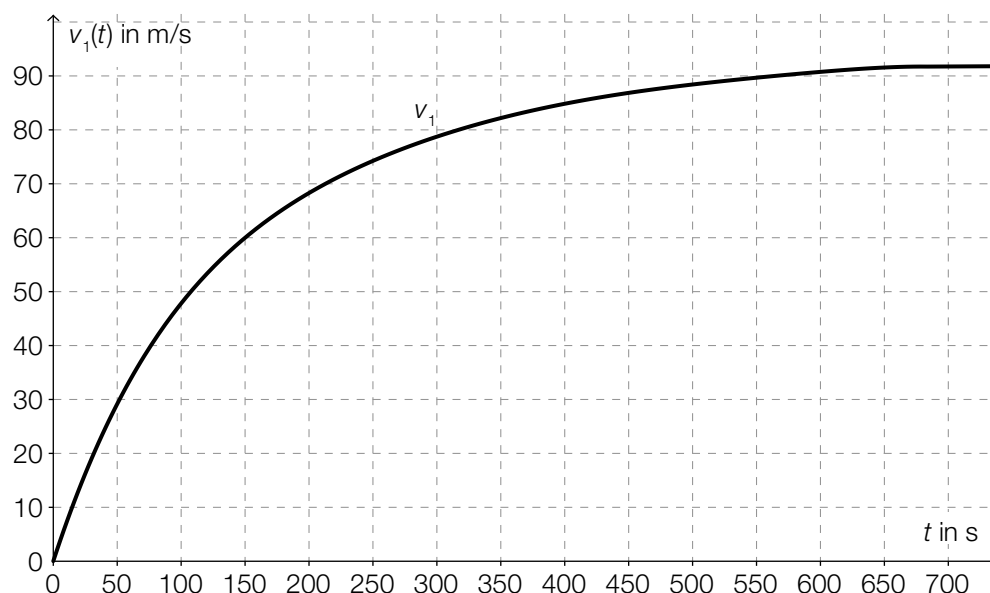

Determine the average rate of change of the velocity in the time interval  $[0 \text{ s}, 700 \text{ s}]$  and write down a time at which the instantaneous rate of change of the velocity is higher than the average rate of change.

A Interpret the definite integral  $\int_0^{700} v_1(t) dt$  in the given context.

- b) Data was collected during a braking test. This data can be described by the distance covered,  $s(t)$ , as a function of time,  $t$ , as  $s(t) = 70 \cdot t - 0.25 \cdot t^2$ , where  $t$  is in seconds and  $s(t)$  is in metres from the start of braking.

Determine the time-velocity function,  $v_2$ , for the braking test in the form  $v_2(t) = m \cdot t + c$  and explain the meaning of the parameters  $m$  and  $c$  in terms of the context described above.

Determine the distance the ICE covered from the start of braking until the standstill.

## Task 2

### ZAMG Weather Balloon

A weather balloon is a balloon filled with helium or hydrogen that is used in meteorology to transport radiosondes (measurement instruments). The Centre for Meteorology and Geodynamics (ZAMG) releases a weather balloon from the *Hohe Warte* weather station twice a day on 365 days of the year. During the ascent, measurements of temperature, humidity, air pressure, wind direction, and wind speed are taken continually.

The values recorded on one ascent of a weather balloon for air pressure and the temperature at the height,  $h$ , above sea level are shown in the table below.

Height $h$ of the balloon above sea level (in m)	Air pressure $p$ (in hPa)	Temperature (in °C)
1 000	906	1.9
2 000	800	-3.3
3 000	704	-8.3
4 000	618	-14.5
5 000	544	-21.9
6 000	479	-30.7
7 000	421	-39.5
8 000	370	-48.3

#### Task:

- a)  A Determine the relative rate (percentage) of change of the air pressure during the ascent of the weather balloon from 1 000 m to 2 000 m. Give your answer as a percentage.

The relationship between the air pressure and the height can be approximated by an exponential function. Explain how this can be justified based on the table above.

- b) In the interval [5 000 m, 8 000 m] the temperature is dependent on the height. This relationship can be described by a linear function,  $T$ .

Explain how this can be justified based on the values given in the table above.

For this function  $T$ , where  $T(h) = m \cdot h + c$ , determine the values of the parameters  $m$  and  $c$ .

- c) The volume of the weather balloon is approximately indirectly proportional to the air pressure,  $p$ .  
At a height of 1 000 m, the weather balloon has a volume of 3 m<sup>3</sup>.

Express the relationship between the volume (in m<sup>3</sup>) and the air pressure (in hPa) in an equation.

$$V(p) = \underline{\hspace{10cm}}$$

Determine the absolute value of the change in the volume of the balloon in the interval [1 000 m, 2 000 m].

## Task 3

### Income Tax

Employees have to pay part of their income to the state in the form of income tax. In the tax model for 2015 there are four tax brackets with the tax rates: 0 %, 36.5 %, 43.2 % and 50 %.

A person's net income can be calculated as follows:

Net income for the year = taxable income for the year – income tax

An income tax calculation is based on the taxable income for the year. For the year 2015 income tax should be calculated as follows:

- Any income up to an amount of € 11,000 is tax exempt.
- Any income that exceeds € 11,000 up to an amount of € 25,000 is taxed at a rate of 36.5 %. This means that if the income is above € 11,000, then the first € 11,000 earned is tax exempt and the income up to € 25,000 is taxed at a rate of 36.5 %.
- Any income that exceeds € 25,000 up to an amount of € 60,000 is taxed at a rate of 43.2 % (or, more precisely  $43\frac{3}{14}$  %).
- Any income that exceeds € 60,000 is taxed at a rate of 50 %.

On July 7<sup>th</sup> 2015, a tax reform law was passed by the National Assembly. This tax model came into force on January 1<sup>st</sup> 2016, and has seven tax brackets. The model used in 2015 (with four tax brackets) and the model that is used in 2016 (with seven tax brackets) are represented on the diagram below.

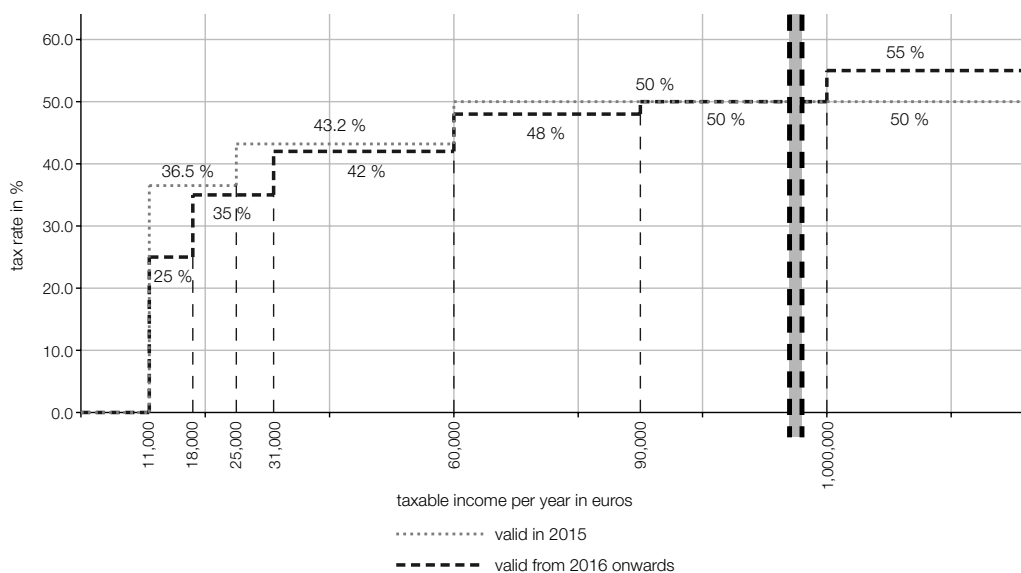

Data source: [http://www.parlament.gv.at/ZUSD/BUDGET/BD\\_-\\_Steuerreform\\_2015\\_und\\_2016.pdf](http://www.parlament.gv.at/ZUSD/BUDGET/BD_-_Steuerreform_2015_und_2016.pdf), p. 15 [11.11.2015]

### Task:

- a)  Using the tax rates for 2015, calculate the net income for the year for a person whose taxable income was € 20,000.

For the year 2015, write down a formula that gives the net income for the year,  $N$ , for a person whose taxable income,  $E$ , is between € 11,000 and € 25,000.



b) The so-called composite tax rate is defined as follows:

$$\text{composite tax rate} = \frac{\text{income tax paid}}{\text{taxable income for the year}}$$

In the year 2015, a person registered a taxable income of € 40,000. Determine this person's composite tax rate for the year 2015.

Using the diagram given, explain what can be calculated with the following expression:

$$7\,000 \cdot 0.115 + 7\,000 \cdot 0.015 + 6\,000 \cdot 0.082 + 9\,000 \cdot 0.012$$

c) A person states:

(1) "Despite the change in law, there would be no change in the amount of tax paid on a taxable income of € 100,000."

(2) "The tax rate for a taxable income of between € 11,000 and € 18,000 has changed by 11.5 %."

Are these statements true? Demonstrate mathematically why each statement is true or false.

d) The Ministry of Finance has the following formula on its website for the calculation of the income tax (Est) for 2015 for the tax bracket from € 25,000 to € 60,000:

$$\text{Est} = \frac{(\text{taxable income for the year} - 25\,000) \cdot 15\,125}{35\,000} + 5\,110$$

Explain the meaning of the factor  $\frac{15\,125}{35\,000}$  and the number 5 110 based on the income tax calculation.

Write down a formula to calculate the income tax ( $\text{Est}_{\text{new}}$ ) for a taxable income between € 31,000 and € 60,000 for the 2016 tax model.

$$\text{Est}_{\text{new}} = \underline{\hspace{15em}}$$

## Task 4

### Dice with Different Numbers

The nets of three fair dice are given below. The dice have various numbers written on their sides in different ways. (A dice is considered to be “fair” if the probability of the dice showing any of its six faces after being thrown is the same.)

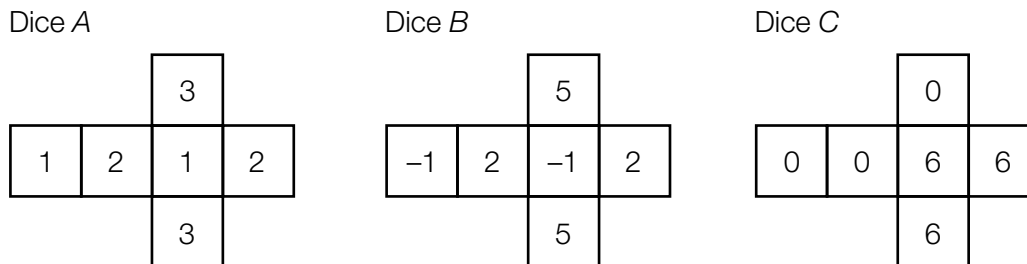

Task:

- a) Mr. Fischer throws dice A twice. The random variable  $X$  represents the sum of the two numbers that come up. The random variable  $X$  can take the values 2, 3, 4, 5 and 6. Mrs. Fischer throws dice A and dice B. The random variable  $Y$  represents the sum of the two numbers that come up.

A Write down all the possible values that the random variable  $Y$  can take.

possible values of  $Y$ : \_\_\_\_\_ .

There are values of the random variables that are more likely to arise for Mr. Fisher than for Mrs. Fisher. Determine the value for which the difference between the two probabilities is the greatest and find this difference.

- b) During a game, dice B is thrown three times. To play the game, a player has to pay € 2. The prize a player receives depends on the sum of the three numbers that come up. The prize money a player receives is outlined in the table below.

Sum of the three numbers	Prize
positive	0
zero	2
negative	?

A person plays this game five times. Determine the probability that the sum of the three numbers that come up is exactly zero in exactly two out of the five games.

Determine the maximum amount the vendor can pay out for a negative sum so that he/she would not make a loss in the long run.

- c) Peter throws dice C 100 times. The random variable  $Z$  represents the number of sixes thrown.

Determine the expectation value and the standard deviation of  $Z$ .

Determine the probability that the sum of the numbers that come up is greater than 350.

## Task 1

### Training for Skiers

A group of skiers is completing training runs on prepared routes. The trainer is focussing her analysis on a 240 m long section from the starting block,  $A$ , to a point  $B$ . By using video analysis, the trainer determines the distance covered by the skiers in dependence to the time taken.

For a particular training run, a skier's distance covered can be modelled as a function,  $s$ , of the time taken for her journey from  $A$  to  $B$ . This function is as follows:  $s(t) = -\frac{1}{144} \cdot t^4 + \frac{8}{3} \cdot t^2$ . The skier leaves the starting block at time  $t = 0$ . The time  $t$  is measured in seconds and the function  $s(t)$  gives the distance covered up to time  $t$  in metres.

The questions below refer to the distance-time function  $s$  described above.

#### Task:

- a) In order to be able to check the efficacy of the skier's start, her average speed,  $\bar{v}$ , in the time period  $[0 \text{ s}, 3 \text{ s}]$  is calculated.

Determine the skier's average speed  $\bar{v}$  in m/s.

Find the time required for the skier to travel from  $A$  to  $B$ .

- b)  Find the time  $t_1$  at which  $s''(t_1) = 0$ .

Interpret  $t_1$  within the context of the skier's journey from  $A$  to  $B$ .

- c) Determine the instantaneous speed of the skier at time  $t_2 = 6$ .

Assume that the skier's speed remains constant from time  $t_2$ . Determine after how many seconds from the point of time  $t_2$  the skier would reach point  $B$ .

- d) In a mathematical model of the distance covered by the skier dependent on the time taken, the following conditions are valid:

- (1) At time  $t = 0$  the skier's instantaneous speed is 0 m/s.
- (2) During the journey from  $A$  to  $B$ , the distance covered is strictly monotonically increasing.

Write down the mathematical properties of a differentiable distance-time function,  $s_1$ , that are guaranteed by these conditions.

## Task 2

### Population Growth in the USA

The first census in the USA took place in 1790. Since this time censuses have been held at ten year intervals. Between censuses the number of inhabitants is calculated using public records.

The information below shows an overview of the population development in the USA from 1790 to 1890 (in the table) and from 2003 to 2013 (in the diagram).

Table: Population development in the USA from 1790 to 1890

Year	Number of inhabitants in millions	Year	Number of inhabitants in millions
1790	3.9	1850	23.2
1800	5.2	1860	31.4
1810	7.2	1870	38.6
1820	9.6	1880	49.3
1830	12.9	1890	62.9
1840	17.1		

Source: Keller, G. (2011). *Mathematik in den Life Sciences*. Stuttgart: Ulmer, p. 55.

Diagram: Population development in the USA from 2003 to 2013

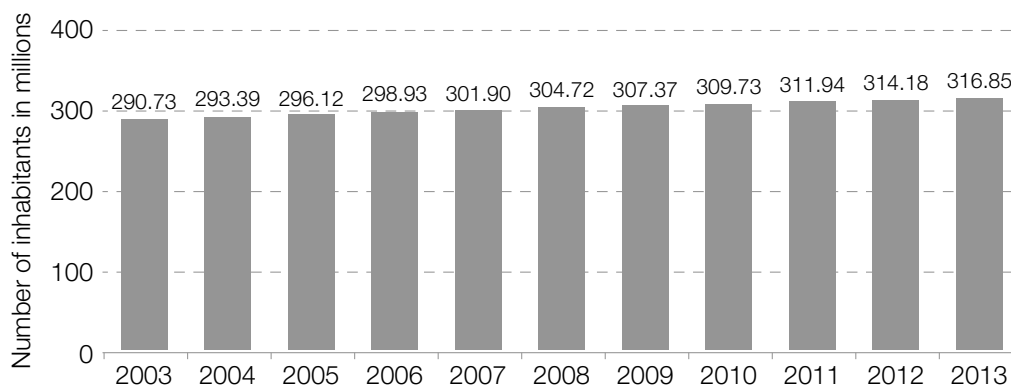

Data source: <http://de.statista.com/statistik/daten/studie/19320/umfrage/gesamtbevoelkerung-der-usa/> [19.09.2013] (adapted).

For the time period from 1790 to 1890, the development of the number of inhabitants in the USA can be approximated by an exponential function,  $B$ , where  $B(t) = B_0 \cdot a^t$ . The time,  $t$ , is measured in years elapsed since 1790 and  $B(t)$  is measured in millions of inhabitants.

Task:

- a) Determine an equation of the function  $B$  by using the data from the years 1790 and 1890.

Interpret the integral  $\int_0^{50} B'(t) dt$  in the given context.

- b) The first derivative of the function  $B$  is given by  $B'(t) = B_0 \cdot \ln(a) \cdot a^t$ .

Write down the value of  $t^*$  such that  $B'(t^*) = B_0 \cdot \ln(a)$  holds.

Interpret  $B'(t^*)$  in the context of the population growth in the USA.

- c)  A Justify why population growth in the USA in the time period from 2003 to 2013 can be approximated by a linear function  $N$ , where  $N(t) = k \cdot t + d$  (where  $t$  is the time in years that have elapsed since 2003).

Interpret the meaning of the parameter  $k$  of this linear function. A calculation of the parameter  $k$  is not required.

## Task 3

### Pong

The first globally popular video game was *Pong*, which was released in 1972 by the company Atari. (Source: <http://de.wikipedia.org/wiki/Pong>)

The principle of Pong is as follows: A point (or “ball”) moves in straight lines backwards and forwards across the screen. Each of the two players controls a vertical line (or “paddle”) which she/he can move upwards and downwards using a joystick. If the ball misses a player’s paddle and travels off the screen, then the player’s opponent gets one point.

The playing field in which the ball and paddle move has a width of 800 pixels and a height of 600 pixels (a pixel is a square point on the screen). As a simplification, it will be assumed that the ball can be represented as a pixel.

When the ball hits either the upper or lower edges of the playing field or a paddle, it is reflected back. The law of reflection, which says that  $\alpha = \beta$  (see diagram below), holds in this case.

The playing field can be imagined as a plane with a coordinate system. The point (1, 1) can be found in the bottom left-hand corner and the point (800, 600) can be found in the top right-hand corner.

The image on the screen is refreshed every 0.02 seconds. The velocity vector  $\vec{v} = \begin{pmatrix} v_x \\ v_y \end{pmatrix}$  of the ball describes the number of pixels by which the ball has moved from one image to the next in the horizontal direction ( $v_x$ ) and the vertical direction ( $v_y$ ).

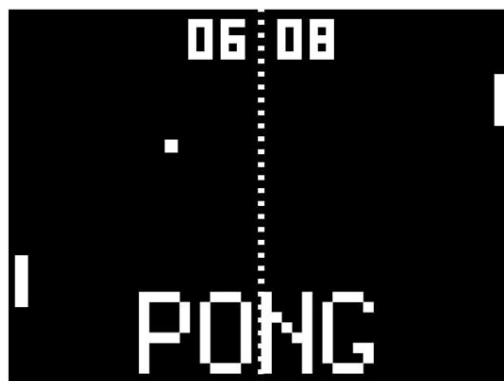

Picture source: [http://www.overclockers.at/games\\_forum/euer-erstes-computerspiel\\_237146/page\\_2](http://www.overclockers.at/games_forum/euer-erstes-computerspiel_237146/page_2) [15.10.2015].

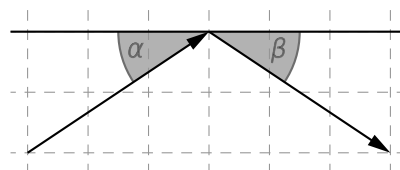

Task:

- a) In a particular game, the ball has a velocity vector of  $\vec{v} = \begin{pmatrix} 4 \\ 7 \end{pmatrix}$  pixels per image when it hits the upper edge of the playing field.

A Determine the angle  $\alpha$  at which the ball hits the edge of the playing field.

$$\alpha = \underline{\hspace{4cm}}$$

The velocity vector always has integer components. Assume that the sum of the absolute values of the components can never be greater than 20.

The ball is reflected by the upper edge of the playing field at an angle of  $\beta$ . What is the smallest value,  $\beta_{\min}$ , that the angle  $\beta$  can have under these conditions? Determine  $\beta_{\min}$ .

$$\beta_{\min} = \underline{\hspace{4cm}}$$

- b) In another game, the ball is at point (401, 301) and its velocity vector is  $\vec{v} = \begin{pmatrix} 2 \\ -3 \end{pmatrix}$  pixels per image.

Determine how many *seconds* it takes for the ball to be reflected by the lower edge of the playing field.

After this reflection the ball moves in a straight line until it hits either a paddle or the edge of the playing field.

Determine the vector equation of this straight line.

- c) Two children, Nicola and Florian, have been playing *Pong* against each other for a long time. Out of 45 games, Nicola has won 31 times and Florian has won 14 times.

On the basis of this information, find a symmetrical 95 % confidence interval for the probability that Nicola wins.

Explain why it does not make sense to find a 100 % confidence interval.

## Task 4

### Roulette

In the game *roulette*, players try to guess either the number or group of numbers that will come up when a ball is thrown into the roulette machine.

In *French roulette*, the roulette machine is comprised of a wheel that sits within a bowl. This wheel is divided into 36 numbered sections that are alternately coloured red and black and a 37<sup>th</sup> green section for the number zero (see Diagram 1). The roulette wheel is spun and the ball is thrown into the wheel in the direction opposite to the direction of rotation. Through this process, the probability of the ball landing in any of the numbered sections is equal and there is no possibility to influence the outcome of the game (for example by throwing the ball in a special manner).

The aim of the game is to guess in advance which numbered section the ball will land in.

The playing tokens (chips) are placed on the roulette table layout (see Diagram 2). The areas containing, for example, the “1” and the “7” are red (“rouge”) and those containing the “4” and the “6” are black (“noir”).

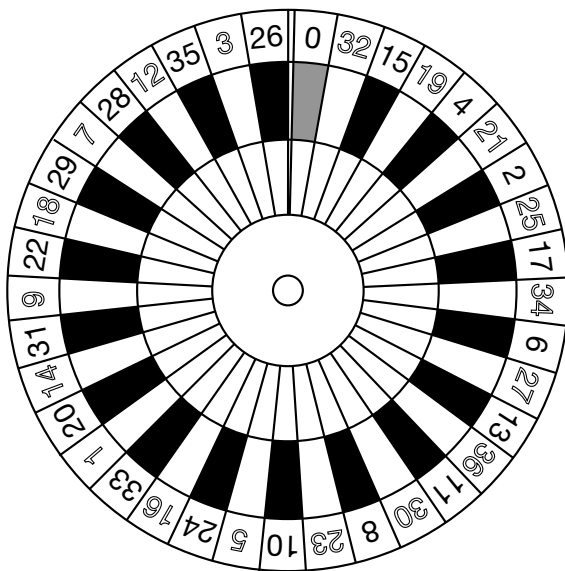

Diagram 1

Source: [http://www.rouletteplay.com/images/software\\_logos\\_small/european-roulette-wheel.gif](http://www.rouletteplay.com/images/software_logos_small/european-roulette-wheel.gif) [23.03.2016].

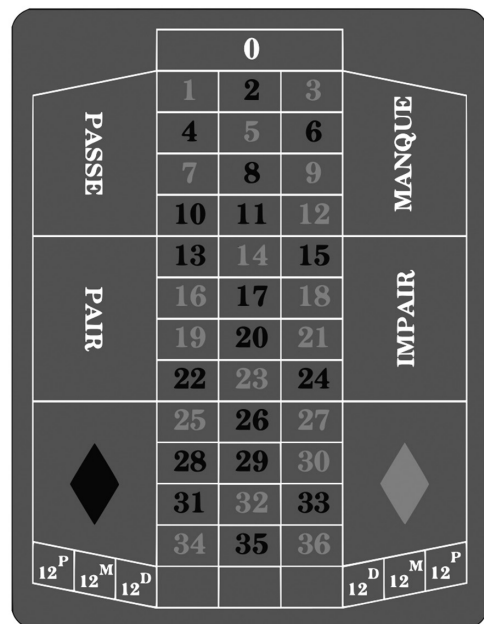

Diagram 2

Source: [https://commons.wikimedia.org/wiki/File:Roulette\\_frz.png](https://commons.wikimedia.org/wiki/File:Roulette_frz.png) [23.03.2016].



Task:

- a) A person argues: "If in five games the ball lands on a red section five times in a row, then on the sixth game the ball is more likely to land on a black section than a red one because 'rouge' and 'noir' should occur with the same frequency over the course of many games." Write down whether or not this explanation is correct and justify your answer.

On one evening 100 games are played at a roulette table.

Find the probability that the ball lands in a red section at most 40 times.

- b) In the table below some of the betting possibilities as well as their corresponding pay-outs are listed.

Type of bet	Pay-out
Rouge: The ball lands in a red section.	1 : 1
Noir: The ball lands in a black section.	1 : 1
12 <sup>P</sup> : first dozen (numbers 1 to 12)	2 : 1
12 <sup>M</sup> : middle dozen (numbers 13 to 24)	2 : 1
12 <sup>D</sup> : final dozen (numbers 25 to 36)	2 : 1
Straight: The chip is placed on one of the 37 numbers.	35 : 1
Split: The chip is placed across two horizontally or vertically adjacent numbers, e.g. 2 and 5 or 8 and 9.	17 : 1

A pay-out of 2 : 1 means, for example, that if a player wins then they receive both the amount that was bet as well as double that amount. If the player loses, then the bet is lost and they receive no money.

In gambling, the house advantage is the expected loss of the player in relation to his/her bet. A player places a bet of € 10 on 12<sup>M</sup>.

Determine the house advantage as a percentage of the bet.

Demonstrate whether the house advantage (as a percentage of the bet) will be bigger, smaller or stay the same if the player places a split bet of €  $a$ . Justify your answer.

## Task 1

### Graphs of Third Degree Polynomial Functions

The shape of a graph of a third degree polynomial function  $f$  with equation  $f(x) = a \cdot x^3 + b \cdot x^2 + c \cdot x + d$  where  $a, b, c, d \in \mathbb{R}$ ,  $a \neq 0$  depends of the values of the coefficients  $a, b, c, d$ .

By choosing values for the coefficients, the number and position of the zeros, maxima, minima and points of inflexion of  $f$ , among other things, are determined.

Task:

- a) What is the greatest number of local maxima and minima that  $f$  can have? Write down this number and justify your answer on the basis of the derivative of  $f$ .

A Show that for the particular case  $a = 1, b = -3, c = 3, d = 0$ , the function  $f$  has no local maxima or minima.

- b) If the relationship  $x \in \mathbb{R}$  holds for all  $f(-x) = -f(x)$  then the graph of  $f$  is symmetrical about the origin.

Write down the values of the coefficients  $b$  and  $d$  for which the graph of  $f$  with equation  $f(x) = a \cdot x^3 + b \cdot x^2 + c \cdot x + d$  would be symmetric about the origin.

For one such function  $f$ , determine the value of the integral  $\int_{-x_1}^{x_1} f(x) dx$  for an arbitrary  $x_1 > 0$  and give an explanation for your solution.

- c) The graph of  $f$  definitely has a point of inflexion. Which of the coefficients  $a, b, c, d$  determines that the point of inflexion of the function  $f$  lies on the vertical axis? Write down this coefficient and the corresponding condition.

Write down an additional condition that is necessary for the graph of  $f$  to have a tangent parallel to the  $x$ -axis at the point of inflexion  $W = (0|f(0))$ .

## Task 2

### Ebola

Ebola is a contagious disease that is caused by a virus. The Ebola epidemic that broke out in many West African countries in 2014 is recognised by the World Health Organisation (WHO) as the worst Ebola epidemic to date. The course of the epidemic was precisely observed and documented by the WHO.

The table below shows an extract of the documentation from the WHO for the countries Guinea, Liberia and Sierra Leone for three days in September 2014. For each day, the total number of people infected (cases) is shown.

Date	6 <sup>th</sup> September	13 <sup>th</sup> September	20 <sup>th</sup> September
Total Number of Cases	4,269	4,963	5,843

Data source: <http://www.who.int/csr/disease/ebola/situation-reports/en/> [20.09.2014].

#### Task:

- a) Write down the meaning of the expressions  $4,963 - 4,269$  and  $\frac{4,963 - 4,269}{4,269}$  in the given context.

Using these expressions, based on the number of cases on the 6<sup>th</sup> September 2014 and the 13<sup>th</sup> September 2014, the number of cases on the 20<sup>th</sup> September 2014 can be predicted on the basis of a linear or an exponential growth model.

Determine the values of both growth models for the 20<sup>th</sup> September 2014, compare the results with the actual data and write down which of the two models is more appropriate for modelling the number of cases within this timeframe.

- b) In mid-September 2014, the *New York Times* cited the claim from scientists that the epidemic could last 12 to 18 months, and that by mid-October 2014 there could be 20,000 people infected.

Data source: <http://www.nytimes.com/2014/09/13/world/africa/us-scientists-see-long-fight-against-ebola.html> [29.06.2016].

The development of the number of cases in an epidemic can, for a limited time, be described by an exponential function. On the basis of the number of people infected on the 6<sup>th</sup> September 2014 and on the 20<sup>th</sup> September 2014, the number of cases should be modelled by an exponential function  $f$  where  $f(t) = a \cdot b^t$ . The time,  $t$ , is measured in days from the 6<sup>th</sup> September 2014, and the time  $t = 0$  corresponds to the 6<sup>th</sup> September 2014.

A Determine the value of  $b$ .

Determine after how many days from the 6<sup>th</sup> September 2014 the number of cases is expected to exceed 20,000 according to the model, and compare your result with the scientists' claim.

## Task 3

### Net Monthly Income

The net monthly income of employed people depends on socioeconomic factors such as age, nationality, education, level of employment and professional position. The table below shows data about the annual average of net monthly incomes of employees in Austria in 2010, broken down by socioeconomic factors. All of the following tasks are related to this data from the year 2010.

Characteristics	Employees in 1,000 people	Arithmetic Mean in euros	10 %	Quartile			90 %
				25 %	50 % (median)	75 %	
earn less than or the same amount as ... (in euros)							
<b>Total</b>	3,407.9	1,872.7	665.0	1,188.0	1,707.0	2,303.0	3,122.0
<b>Age</b>							
15–19 years	173.5	799.4	399.0	531.0	730.0	1,020.0	1,315.0
20–29 years	705.1	1,487.0	598.0	1,114.0	1,506.0	1,843.0	2,175.0
30–39 years	803.1	1,885.7	770.0	1,252.0	1,778.0	2,306.0	2,997.0
40–49 years	1,020.4	2,086.1	863.0	1,338.0	1,892.0	2,556.0	3,442.0
50–59 years	632.8	2,205.0	893.0	1,394.0	1,977.0	2,779.0	3,710.0
60+ years	73.0	2,144.7	258.0	420.0	1,681.0	3,254.0	4,808.0
<b>Highest Level of Education Completed</b>							
Compulsory Education	523.4	1,183.0	439.0	677.0	1,104.0	1,564.0	1,985.0
Apprenticeship	1,385.2	1,789.3	833.0	1,303.0	1,724.0	2,143.0	2,707.0
Vocational Schools	454.4	1,777.1	733.0	1,199.0	1,677.0	2,231.0	2,824.0
College	557.2	2,061.6	590.0	1,218.0	1,824.0	2,624.0	3,678.0
University	487.7	2,723.4	1,157.0	1,758.0	2,480.0	3,376.0	4,567.0
<b>Professional Position</b>							
Apprentice	134.2	775.3	466.0	551.0	705.0	930.0	1,167.0
White Collar Worker	1,800.3	2,018.1	705.0	1,222.0	1,771.0	2,489.0	3,550.0
Blue Collar Worker	1,030.9	1,539.3	627.0	1,135.0	1,554.0	1,922.0	2,274.0
Official	442.5	2,391.4	1,377.0	1,800.0	2,295.0	2,848.0	3,492.0

Data source: Statistik Austria (ed.) (2012). *Arbeitsmarktstatistik. Jahresergebnisse 2011. Mikrozensus-Arbeitskräfteerhebung.* Vienna: Statistik Austria, p. 81 (adapted).

Task:

- a) In the space below, draw a diagram that shows the median incomes of 20 to 59 year olds. For your diagram, use the median incomes rounded to two decimal places.

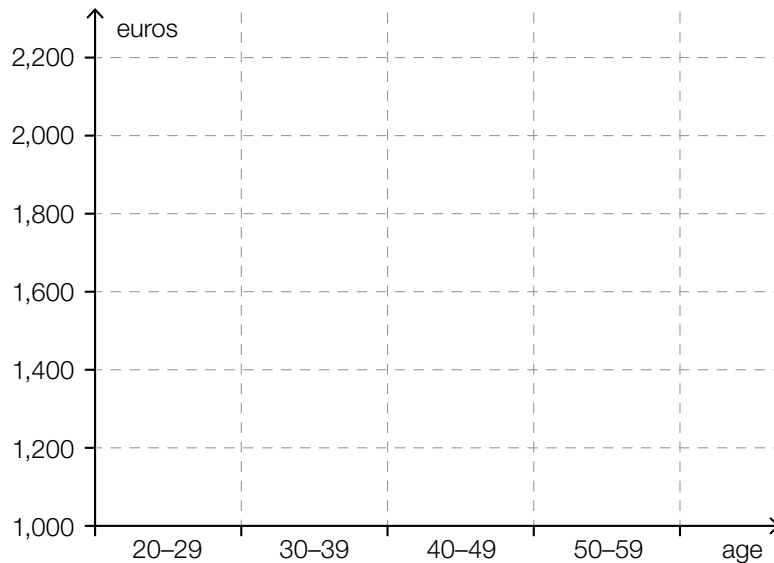

Is it possible to represent the net monthly income of 20 to 29 year olds and the 30 to 39 year olds in boxplots on the basis of the data given in the table? Justify your answer.

- b) Someone calculated the arithmetic mean of all net monthly incomes by using the means of the six age groups in the following way:

$$\frac{799.4 + 1,487.0 + 1,885.7 + 2,086.1 + 2,205.0 + 2,144.7}{6} \approx 1,768.0$$

However, in the table given the arithmetic mean of all incomes is shown as 1,872.7.

Explain why the calculation shown above does not give the correct result and write down the correct method for this calculation.

For the age group 60+, the arithmetic mean of the net monthly incomes is considerably larger (by almost € 500) than the median income for this age group. Write down the inference that can be made on the basis of the very low or very high net monthly incomes in this age group.

- c)  Write down the values of the 1<sup>st</sup> and 3<sup>rd</sup> quartiles of the net monthly incomes of the employees whose highest completed level of education is compulsory education.

1<sup>st</sup> quartile: \_\_\_\_\_

3<sup>rd</sup> quartile: \_\_\_\_\_

The interquartile range is the difference of the 3<sup>rd</sup> and 1<sup>st</sup> quartiles.

An expert claims: "With increasing levels of completed education that exceed compulsory education, the interquartile range of the net monthly incomes increases." Verify or contradict this statement by using the data given in the table.

- d) The data given in the table shows that around 53 % of the employees are white collar workers and around 30 % are blue collar workers.

A comment about the labour market report says: "The relative proportion of white collar workers is approximately 23 % higher than the relative proportion of blue collar workers." Is this statement correct? Justify your answer.

Check the following statements about net monthly incomes on the basis of the given data. Put a cross next to each of the two correct statements.

White collar workers earn, on average, over € 500 more than blue collar workers.	<input type="checkbox"/>
At most a quarter of blue collar workers earn more than € 1,922.	<input type="checkbox"/>
From the data of the table, the range of net monthly income cannot be stated exactly.	<input type="checkbox"/>
Three quarters of apprentices earn at least € 930.	<input type="checkbox"/>
Precisely half of officials earn exactly € 1,800.	<input type="checkbox"/>

## Task 4

### Solar Power in Austria

In a photovoltaic plant, sunlight is converted into electric energy by solar cells and thereby “solar power” is created. In Austria, solar panels work most efficiently if they are directed towards the south.

For this purpose, there are two different systems: the supported systems, which mean that the solar panels can be moved depending on the direction of the Sun's rays, and the cheaper roof-mounted systems that remain parallel to the roof.

Excess electricity can be fed into the public grid, which further lowers the electricity costs of a household.

The diagram below shows the increase in solar power since the year 2000.

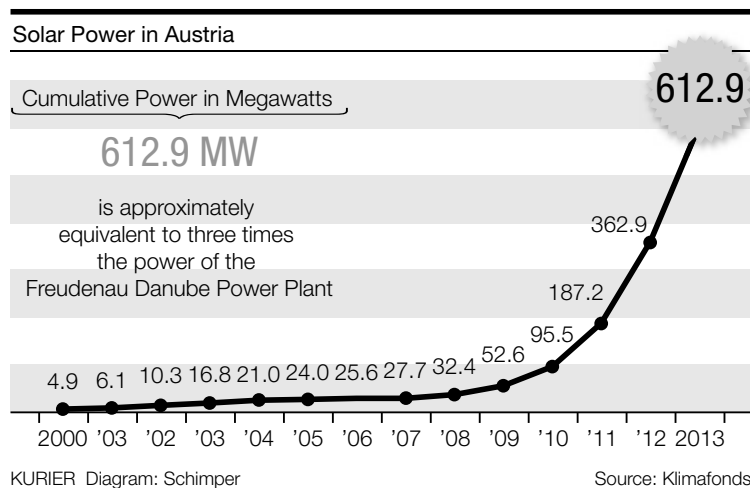

Source: <http://kurier.at/wirtschaft/ein-oel-mann-wird-zum-solar-fan/42.474.775> [28.06.2016] (adapted).

The number of years since the year 2000 is given by  $t$  and  $f(t)$  represents the power (in MW) after  $t$  years shown in the diagram above.

Task:

- a)  A Determine and interpret the difference quotient  $\frac{f(13) - f(0)}{13}$  in the given context.

Write down the meaning of the integral  $\int_0^{13} f(t) dt$  with respect to the creation of solar power.

- b) Justify why the power (in MW) shown in the diagram above for the time period [9 years, 12 years] can be approximated well by an exponential function  $g$  with equation  $g(t) = a \cdot b^t$ .

Determine the expression  $\frac{f(12) - f(9)}{f(9)} + 1$  by using the parameter  $b$  of the function  $g$ .

- c) Energy production from a photovoltaic plant is highest if the Sun's rays fall at right angles onto the solar cells.

Thus, the optimal tilt of a photovoltaic panel depends on the angle of incidence of the Sun's rays. For the northern hemisphere, this angle is largest on the 21<sup>st</sup> June.

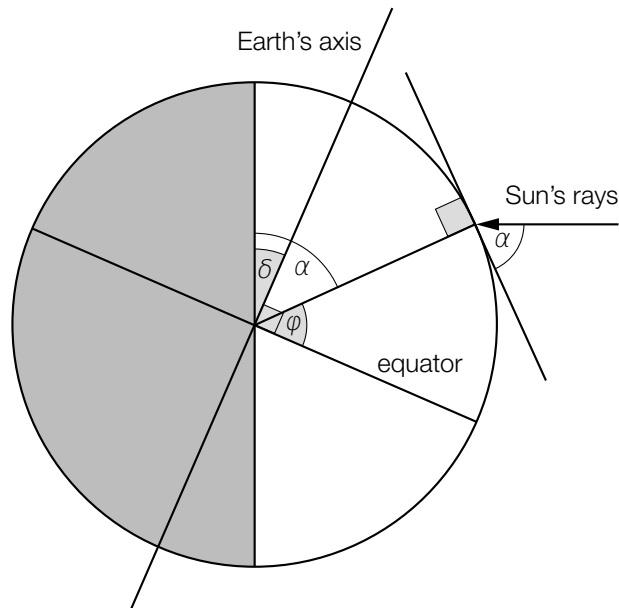

In the diagram above, the angle of incidence of the Sun's rays,  $\alpha$ , is shown on 21<sup>st</sup> June at noon. The angle  $\delta \approx 23.5^\circ$  gives the tilt of the Earth's axis to the orbital plane of the Sun and the angle  $\phi$  the latitude.

Determine a formula for the angle of incidence  $\alpha$  of the Sun's rays dependent on the latitude  $\phi$ .

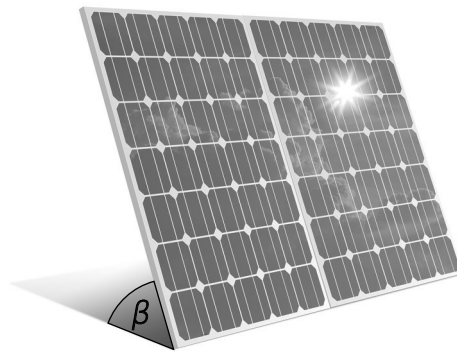

Source: <http://www.solaranlage.eu/sites/default/files/bilder/reflexionsverluste-solarmodule.jpg> [14.11.2016] (adapted).

The diagram above shows photovoltaic panels that are tilted at an angle of  $\beta$  to the horizontal. These solar panels are facing towards the Sun.

Determine a formula for the optimal tilting angle of the photovoltaic panels,  $\beta_{\text{opt}}$ , in terms of  $\alpha$  so that the Sun's rays are perpendicular to the panel. Write down how this angle changes in winter or at higher latitudes. Justify your answer.