

Task 1

Comparison of Two Sets

The set $A = \{x \in \mathbb{N} \mid 1 < x < 8\}$ is a subset of the natural numbers, and the set $B = \{x \in \mathbb{Q} \mid 1 < x < 8\}$ is a subset of the rational numbers.

Task:

Put a cross next to each of the two correct statements. [2 out of 5]

Both sets A and B contain rational numbers.	<input type="checkbox"/>
Set B is a subset of set A .	<input type="checkbox"/>
The two sets A and B contain exactly the same number of numbers.	<input type="checkbox"/>
Set A contains exactly 6 numbers that are also contained in set B .	<input type="checkbox"/>
Both sets A and B contain numbers that are greater than 7.	<input type="checkbox"/>

[0/1 p.]

Task 2

Apples and Apricots

A particular fruit seller sells apples and apricots.

The price for 1 kg of apples is a euros; the price for 1 kg of apricots is m euros ($a, m \in \mathbb{R}^+$).

The following statements hold:

- 1 kg of apricots costs 80 % more than 1 kg of apples.
- 1 kg of apricots costs 1.40 euro more than 1 kg of apples.

Task:

Put a cross next to each of the two correct equations. [2 out of 5]

$a \cdot 0.8 = m$	<input type="checkbox"/>
$a + 1.8 = m$	<input type="checkbox"/>
$a = m - 1.4$	<input type="checkbox"/>
$a = \frac{m}{1.4}$	<input type="checkbox"/>
$\frac{m}{a} = 1.8$	<input type="checkbox"/>

[0/1 p.]

Task 3

System of Equations

A system of equations in x and y with $a, c \in \mathbb{R}$ is shown below.

$$\text{I: } 2 \cdot x - y = 3$$

$$\text{II: } a \cdot x + 2 \cdot y = c$$

This system of equations has no solution.

Task:

Write down a value for each of a and c .

$$a = \underline{\hspace{2cm}}$$

$$c = \underline{\hspace{2cm}}$$

[0/1 p.]

Task 4

Vectors

Let $\vec{a}, \vec{b} \in \mathbb{R}^2$ be vectors.

Task:

Match each of the four diagrams to the statement from A to F that corresponds to the vectors \vec{a} and \vec{b} shown.

	<input type="checkbox"/>	A $(\vec{a} - \vec{b}) \perp \vec{b}$
	<input type="checkbox"/>	B $\vec{a} \cdot \vec{b} = 0$
	<input type="checkbox"/>	C $\vec{b} = \frac{3}{2} \cdot \vec{a}$
	<input type="checkbox"/>	D $\vec{a} = -2 \cdot \vec{b}$
		E $(\vec{a} - \vec{b}) \perp \vec{a}$
		F $\vec{b} = \frac{2}{3} \cdot \vec{a}$

[0/1/2/1 p.]

Task 5

Vector Equation of a Line

Six lines g_1, g_2, \dots, g_6 are represented graphically below. The points shown on the lines have integer coordinates.

Task:

Put a cross next to the line whose vector equation has the form $X = \begin{pmatrix} a_1 \\ a_2 \end{pmatrix} + t \cdot \begin{pmatrix} 3 \\ 1 \end{pmatrix}$ with $t \in \mathbb{R}$ and $a_1, a_2 \in \mathbb{Z}$. [1 out of 6]

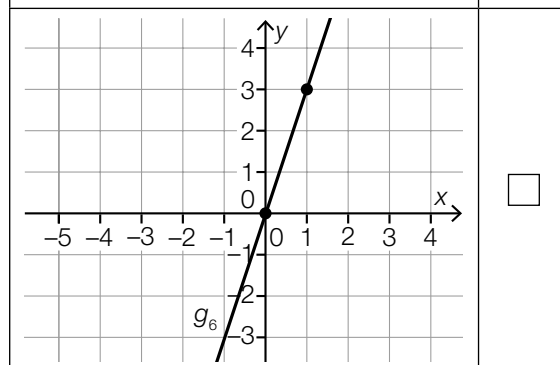
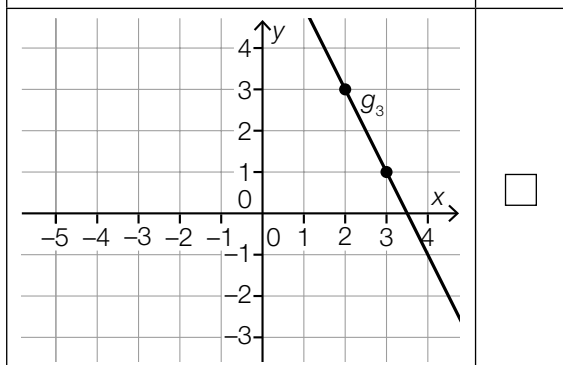
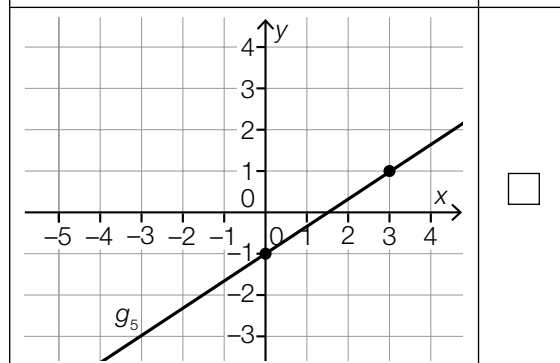
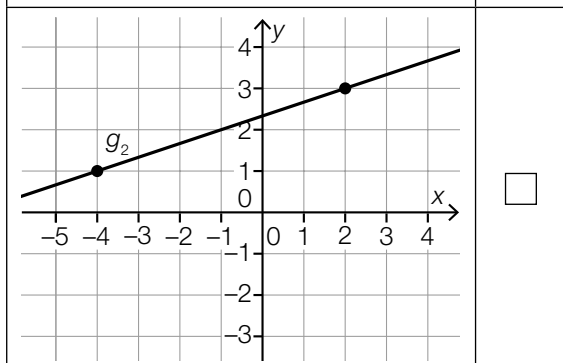
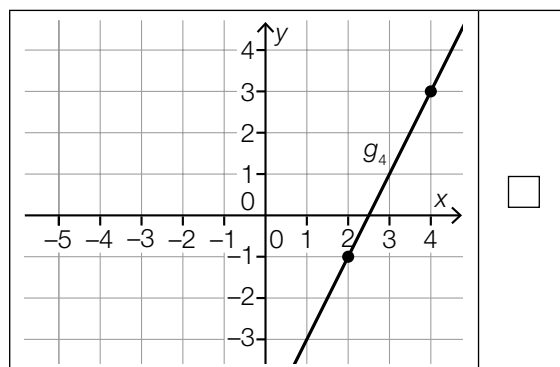
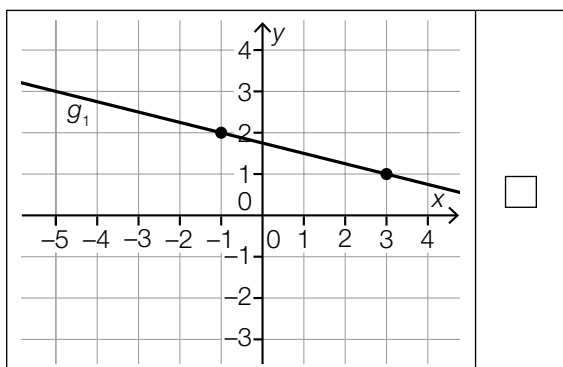

[0/1 p.]

Task 6

Unit Circle

For the angle $\alpha \in [0^\circ, 360^\circ)$, the following statements hold:

$$\sin(\alpha) = -0.5 \text{ and } \cos(\alpha) < 0$$

A unit circle is shown in the coordinate system below.

Task:

On this coordinate system, draw the point $P = (\cos(\alpha), \sin(\alpha))$.

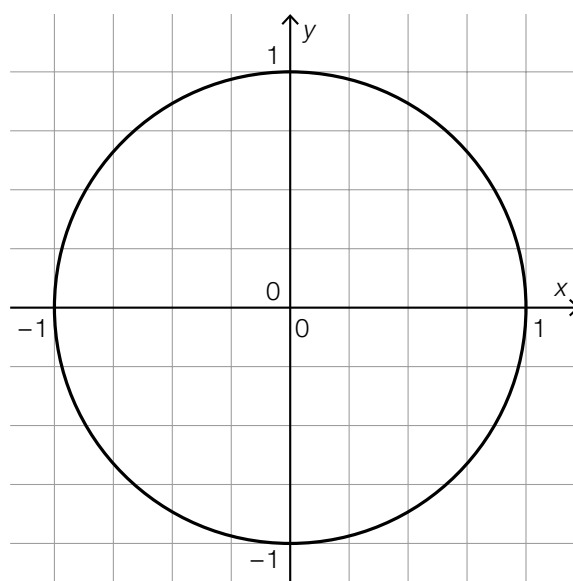

[0/1 p.]

Task 7

Acceleration

A body moves along a straight line with constant acceleration in the time interval $[0, 5]$ and comes to rest at the time $t = 5$.

The following statement holds for the acceleration: $a(t) = -0.4$

t ... time in s

$a(t)$... acceleration at time t in m/s^2

$v(t)$... velocity at time t in m/s

$s(t)$... displacement at time t in m

The movement of the body is represented correctly in two of the diagrams shown below.

Task:

Put a cross next to each of the two correct diagrams. [2 out of 5]

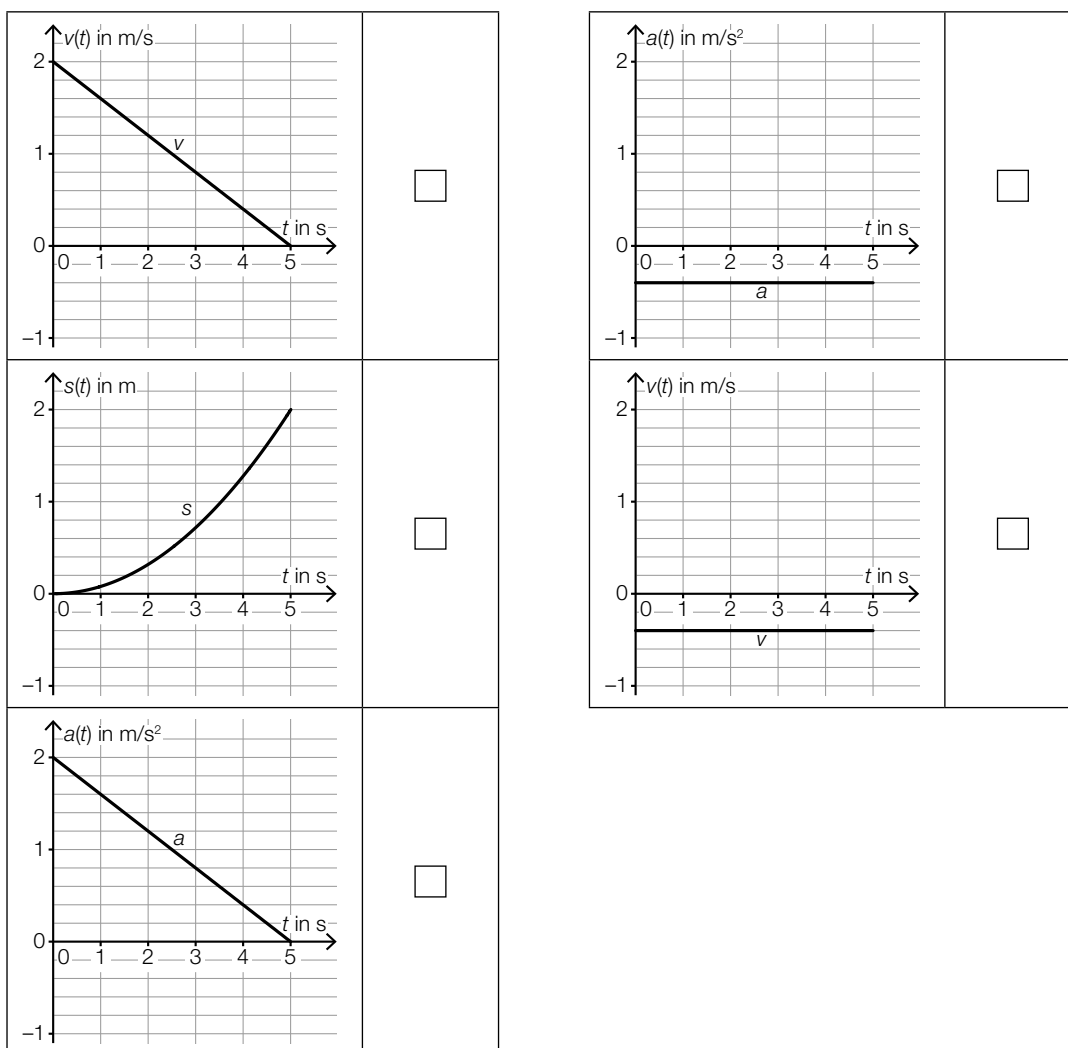

Task 8

Racing Bike

The following values are given in the handbook of a racing bike:

number of crank turns per minute	velocity in km/h
60	28.8
85	40.8

The velocity can be modelled in terms of the number of crank turns by the linear function v .

x ... number of crank turns per minute

$v(x)$... velocity at x crank turns per minute in km/h

Task:

Write down an equation of v .

$v(x) =$ _____

[0/1 p.]

Task 9

Power Function

Let $f: \mathbb{R} \setminus \{0\} \rightarrow \mathbb{R}$ be a power function with $f(x) = a \cdot x^z$ with $a \in \mathbb{R} \setminus \{0\}$ and $z \in \mathbb{Z}$.

The following statements hold:

- If the value of the argument x is doubled, then the corresponding value of the function reduces to a quarter of the original value of the function.
- The point $(2, 2)$ lies on the graph of f .

Task:

Write down the values of a and z .

$z =$ _____

$a =$ _____

[0/1 p.]

Task 10

Filling a Water Tank

An empty water tank is filled completely with water.

The function $d: \mathbb{R}^+ \rightarrow \mathbb{R}^+$ gives the filling time in terms of the inflow rate z (z in m^3/h , $d(z)$ in h).

The diagram below shows the graph of d .

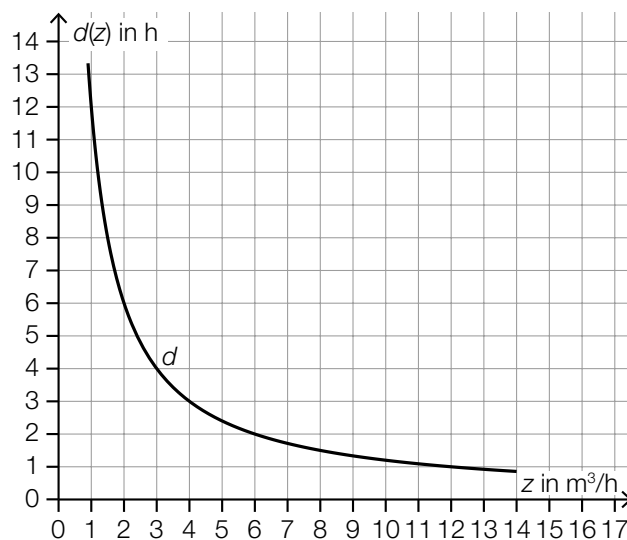

Task:

Write down the volume V of the water tank.

$V =$ _____ m^3

[0/1 p.]

Task 11

Half-Life

The mass of a radioactive substance can be described by an exponential function in terms of the time t . The following statements hold:

$$N(t) = N_0 \cdot e^{-k \cdot t}$$

$N(t)$... mass of the radioactive substance at time t

N_0 ... mass of the radioactive substance at time $t = 0$

$k \in \mathbb{R}^+$... decay constant

The half-life of the radioactive substance is given by τ .

An arbitrary time is given by t^* .

The following statements hold: $t^* \neq \tau$ and $t^* > 0$

Task:

Put a cross next to the expression that is equivalent to $N(t^* + \tau)$. [1 out of 6]

$2 \cdot N_0$	<input type="checkbox"/>
$N(\tau)$	<input type="checkbox"/>
$N\left(\frac{1}{2} \cdot t^*\right)$	<input type="checkbox"/>
$2 \cdot N(\tau)$	<input type="checkbox"/>
$N(2 \cdot t^*)$	<input type="checkbox"/>
$\frac{1}{2} \cdot N(t^*)$	<input type="checkbox"/>

[0/1 p.]

Task 12

Sine Function

The diagram below shows the graph of the function f with $f(x) = a \cdot \sin(b \cdot x)$ with $a, b \in \mathbb{R}^+$.

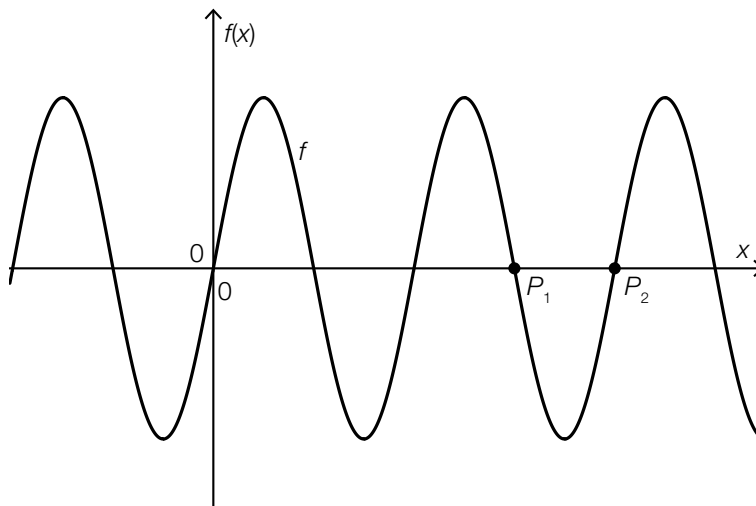

The points $P_1 = (x_1, 0)$ and $P_2 = (x_2, 0)$ with $x_1 = \frac{3 \cdot \pi}{4}$ and $x_2 = \pi$ lie on the graph of f .

The following statement holds: $f\left(\frac{x_1 + x_2}{2}\right) = -3$

Task:

Determine a and b .

$a =$ _____

$b =$ _____

[0/1/2/1 p.]

Task 13

CO₂ Emissions

The table below shows the level of CO₂ emissions in Austria for selected years.

year	1990	2005	2017	2018
CO ₂ emissions in millions of tonnes	78.5	92.5	82.0	79.0

Task:

Determine the following values:

absolute change in CO₂ emissions from 2017 to 2018: _____ millions of tonnes

relative change in CO₂ emissions from 1990 to 2005: _____

[0/½/1 p.]

Task 14

Movement of a Cyclist

The polynomial function s approximates the distance covered by a cyclist in terms of the time t (t in h, $s(t)$ in km).

Task:

Complete the following sentence by putting a cross next to one of the given possibilities for each gap so that the sentence becomes a correct statement.

The expression $\lim_{t \rightarrow 2} \frac{s'(t) - s'(2)}{t - 2}$ describes _____ ① and the expression $\frac{s(t_2) - s(t_1)}{t_2 - t_1}$ describes _____ ②.

①	
the instantaneous acceleration at time $t = 2$	<input type="checkbox"/>
the instantaneous velocity at time $t = 2$	<input type="checkbox"/>
the distance covered until time $t = 2$	<input type="checkbox"/>

②	
the average acceleration in the time interval $[t_1, t_2]$	<input type="checkbox"/>
the average velocity in the time interval $[t_1, t_2]$	<input type="checkbox"/>
the distance covered in the time interval $[t_1, t_2]$	<input type="checkbox"/>

[0/½/1 p.]

Task 15

Parachute Jump

The velocity of a parachutist during a particular parachute jump can be modelled in terms of the time t over the interval $[0, 14]$ by the differentiable function v (t in s, $v(t)$ in m/s). The diagram below shows the graph of v .

Task:

Label the time t_1 at which the acceleration of the parachutist is 5 m/s^2 on the diagram below.

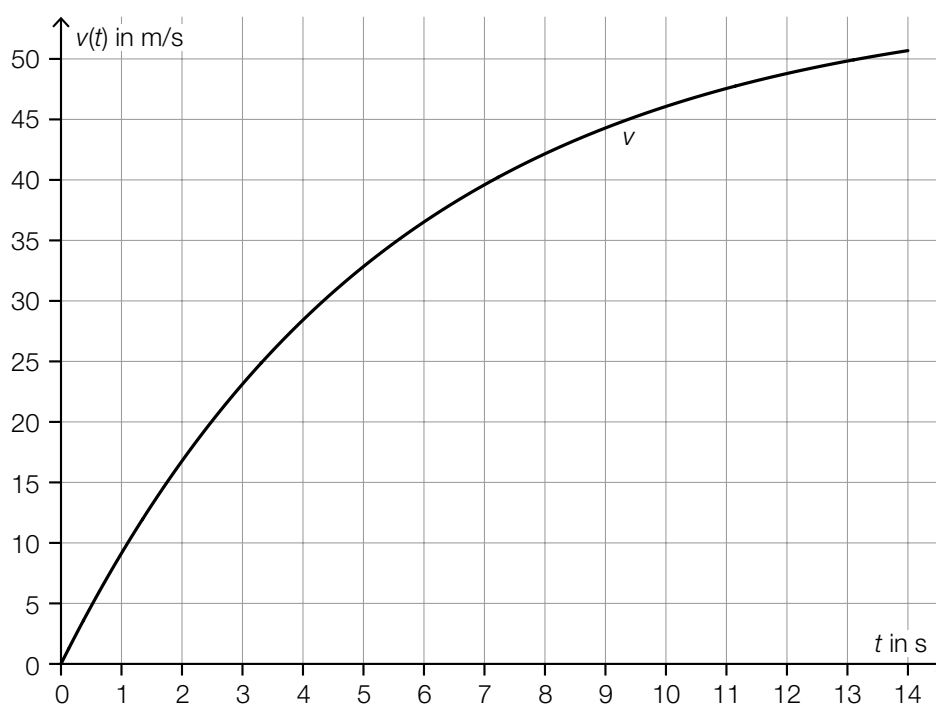

[0/1 p.]

Task 16

Function and Antiderivative

The diagram below shows the graph of the function f and the graph of one of its antiderivatives F .

An area under the graph of the function f has been shaded in grey in the interval $[x_1, x_2]$.

A line segment of length s has been drawn under the graph of F .

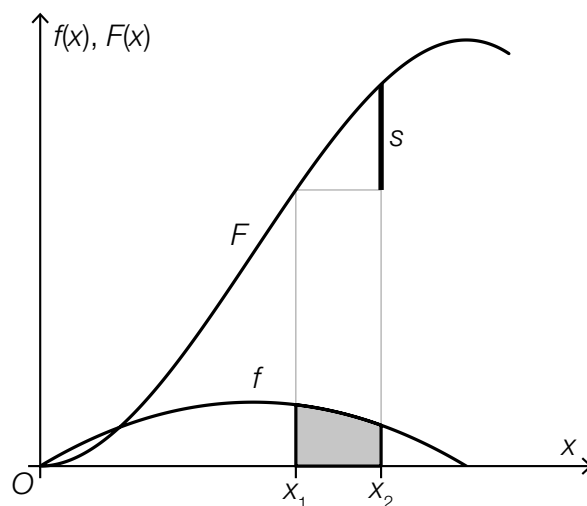

Task:

Put a cross next to the equation that correctly describes the relationship between s and the area shaded in grey. [1 out of 6]

$s = F(x_1) - F(x_2)$	<input type="checkbox"/>
$s = f(x_2) - f(x_1)$	<input type="checkbox"/>
$s = \frac{F(x_1) + F(x_2)}{2}$	<input type="checkbox"/>
$s = \int_{x_1}^{x_2} f(x) dx$	<input type="checkbox"/>
$s = \int_{x_2}^{x_1} f(x) dx$	<input type="checkbox"/>
$s = \int_{x_1}^{x_2} F(x) dx$	<input type="checkbox"/>

[0/1 p.]

Task 17

Properties of Quadratic Functions

Let f and h be two quadratic functions.

For all $x \in \mathbb{R}$, the following statements hold: $f'(x) = h'(x)$ and $f(x), h(x) > 0$

Task:

Put a cross next to each of the two statements that are definitely true. [2 out of 5]

For all $x \in \mathbb{R}$, $h''(x) < 0$ holds.	<input type="checkbox"/>
h' is strictly monotonically decreasing.	<input type="checkbox"/>
There exists a number $c \in \mathbb{R}$ such that for all $x \in \mathbb{R}$, $f(x) - h(x) = c$ holds.	<input type="checkbox"/>
h' is a linear function whose graph goes through the point $(0, 0)$.	<input type="checkbox"/>
f' has a zero.	<input type="checkbox"/>

[0/1 p.]

Task 18

Area between the Graphs of Two Functions

The graphs of the quadratic function f and the linear function g are shown in diagram 1. The graphs of the functions F and G are shown in diagram 2.

The following statements hold:

F is an antiderivative of f .

G is an antiderivative of g .

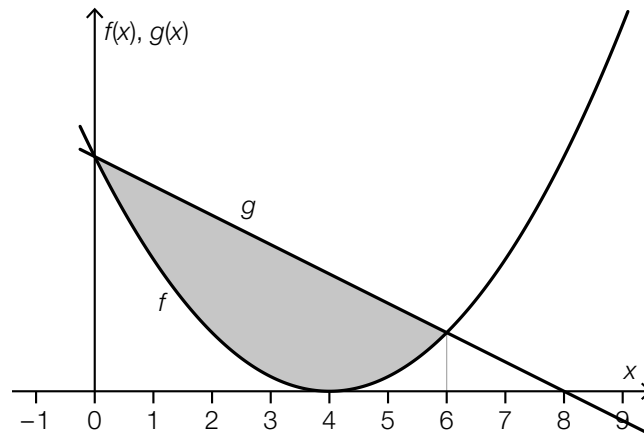

diagram 1

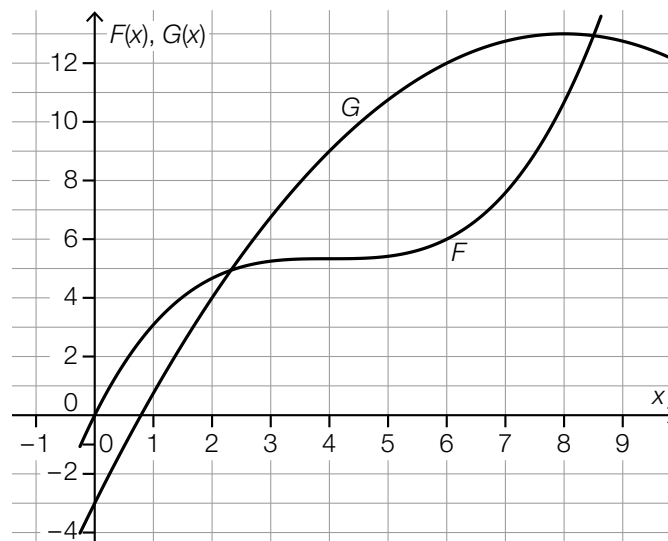

diagram 2

Task:

Using the diagrams, determine the area A of the grey shaded area.

Task 19

Comparison of Two Diagrams

In the diagrams below, the list of data A is represented by a stem and leaf diagram, and the list of data B is represented by a boxplot.

2	1	7	7	9
3	1	3	6	6
4	3			

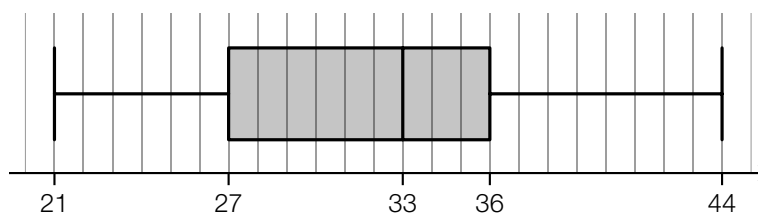

Task:

Put a cross next to each of the two statistics that are different for the lists of data A and B.
[2 out of 5]

1 st quartile	<input type="checkbox"/>
range	<input type="checkbox"/>
3 rd quartile	<input type="checkbox"/>
minimum	<input type="checkbox"/>
median	<input type="checkbox"/>

[0/1 p.]

Task 20

Mean

A particular list of data consists of 20 values and has the mean $\bar{x} = 15.5$.

The values 4, 6, 13, and 27 are removed from this list of data. The remaining list of data with 16 values has the mean \bar{x}_1 .

Task:

Determine the mean \bar{x}_1 .

[0/1 p.]

Task 21

Solution Times for Sudoku

6 games of online sudoku are played. The table below shows the solution times for the first 5 games.

game	solution time in s
1	356
2	321
3	378
4	450
5	298
6	t

The median of all 6 solution times is 350 s.

Task:

Determine t .

$t =$ _____ s

[0/1 p.]

Task 22

Removing Balls

There are n balls in an urn. Of these n balls, 6 balls are red and the rest are white. 2 balls are selected at random and removed from the urn without replacement.

The corresponding probabilities are shown in the tree diagram below.

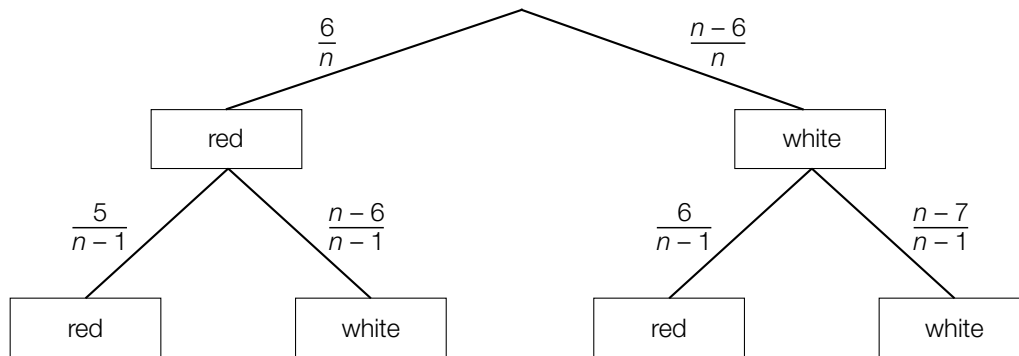

The probability that both of the balls removed are red is p .

Task:

Write down an equation in terms of n that can be used to calculate p .

$p =$ _____

[0/1 p.]

Task 23

Probability Distribution

A fair 6-sided dice with faces numbered 1, 2, 3, 4, 5, and 6 is thrown 2 times. The random variable X describes how often a 6 is thrown in these 2 throws.

Task:

Put a cross next to the diagram that correctly represents the probability distribution of X .
[1 out of 6]

	<input type="checkbox"/>
	<input type="checkbox"/>
	<input type="checkbox"/>
	<input type="checkbox"/>
	<input type="checkbox"/>
	<input type="checkbox"/>

[0/1 p.]

Task 24

Computer Game

A particular computer game consists of a number of rounds to play.

In each round, there are 5 questions each with 4 possible answers of which only 1 possible answer is correct.

A round can be won if more than half of the questions are answered correctly.

The 4 possible answers for each question are arranged at random.

In a particular round, Gerhard chooses the first possible answer for each question without reading the questions.

Task:

Determine the probability that Gerhard wins this round.

[0/1 p.]

Task 1

Knowledge about Sets of Numbers

Let a and b be two natural numbers with $b > a$.

Task:

Complete the following sentence by putting a cross next to the correct option for each gap so that the sentence becomes a true statement.

$a - b$ is definitely ^① _____ and $b - a$ is definitely ^② _____.

①	
a natural number	<input type="checkbox"/>
a rational number but not a natural number	<input type="checkbox"/>
a rational number but not an integer	<input type="checkbox"/>

②	
a natural number	<input type="checkbox"/>
an integer but not a natural number	<input type="checkbox"/>
a rational number but not a natural number	<input type="checkbox"/>

[0/½/1 p.]

Task 2

Volume of a Sphere

A particular sphere has radius r and volume V , where $r, V \in \mathbb{R}^+$.
Another sphere has radius $2 \cdot r$ and volume $k \cdot V$.

Task:

Determine k .

$k =$ _____

[0/1 p.]

Task 3

Language Trip

A language trip is attended by U lower-secondary school pupils, O upper-secondary school pupils and B chaperones. The total number of pupils (lower- and upper-secondary) is at least as great as 5 times the number of chaperones.

Task:

Write down an inequality that describes the relationship between U , O and B given above.

[0/1 p.]

Task 4

Vektors in \mathbb{R}^3

Let be $\vec{a} = \begin{pmatrix} a_1 \\ a_2 \\ a_3 \end{pmatrix}$, $\vec{b} = \begin{pmatrix} b_1 \\ b_2 \\ b_3 \end{pmatrix}$ and $\vec{n} = \begin{pmatrix} n_1 \\ n_2 \\ n_3 \end{pmatrix}$ be three non-zero vectors in \mathbb{R}^3 .

The following statements hold:

The vector \vec{n} is perpendicular to both vector \vec{a} and vector \vec{b} .

The vectors \vec{a} and \vec{b} are not perpendicular to each other.

The vectors \vec{a} and \vec{b} are not parallel to each other.

Task:

Put a cross next to each of the two statements that are definitely true. [2 out of 5]

$\vec{a} \cdot \vec{b} = \vec{b} \cdot \vec{n}$	<input type="checkbox"/>
$(\vec{a} + \vec{b}) \cdot \vec{n} = 0$	<input type="checkbox"/>
$a_1 \cdot n_1 + a_2 \cdot n_2 + a_3 \cdot n_3 = 0$	<input type="checkbox"/>
There exists a number $k \in \mathbb{R}$ such that $\vec{a} + \vec{b} = k \cdot \vec{n}$ holds	<input type="checkbox"/>
There exists a number $k \in \mathbb{R}$ such that $\vec{a} = k \cdot \vec{b}$ holds	<input type="checkbox"/>

[0/1 p.]

Task 5

Directions

A path goes from point A via point B to point C . At point B , the path branches off to the right at a right angle. The path is straight between points B and C .

The path AB is modelled in the coordinate system below.

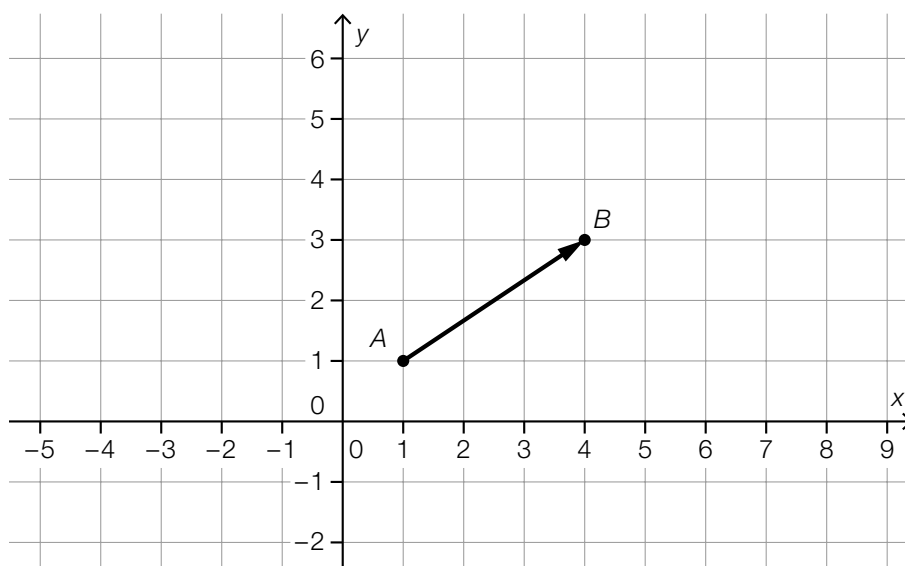

Task:

Write down a vector \vec{a} that gives the direction of the path BC .

$$\vec{a} = \begin{pmatrix} \square \\ \square \end{pmatrix}$$

[0/1 p.]

Task 6

Sine and Cosine

For a particular angle $\alpha \in [0^\circ, 360^\circ)$, the relationship $\sin(\alpha) \geq \cos(\alpha)$ holds.

Task:

Write down the largest possible interval for α such that this relationship holds.

$\alpha \in [\text{_____}^\circ, \text{_____}^\circ]$

[0/1 p.]

Task 7

Profit

The diagram below shows the graph of the cost function $K: x \mapsto K(x)$ and the graph of the revenue function $E: x \mapsto E(x)$ for a particular product (x in units of quantity, $E(x)$, $K(x)$ in monetary units).

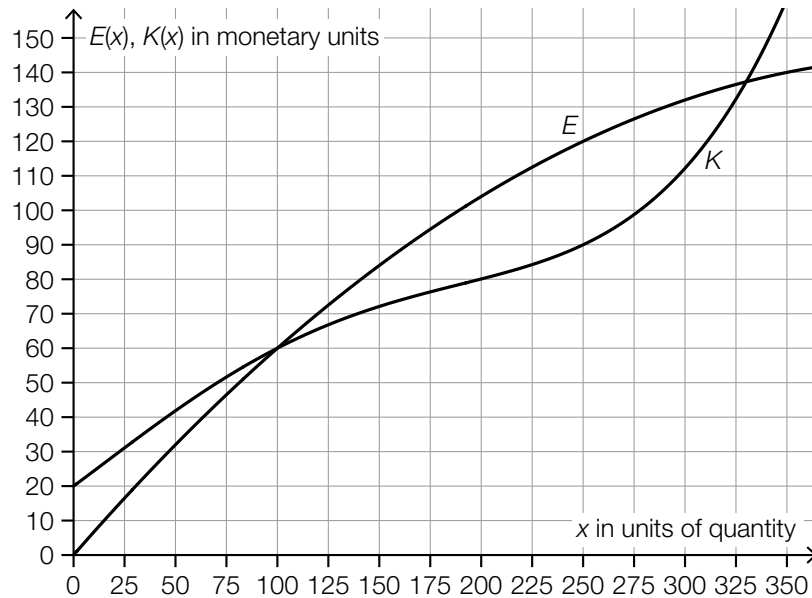

It can be assumed for this product that all of the units of quantity produced are also sold.

A positive profit for this product is first reached at more than x_1 produced and sold units of quantity.

The profit for this product reaches a maximum at x_2 produced and sold units of quantity.

Task:

Determine x_1 and x_2 using the diagram above.

$x_1 =$ _____ units of quantity

$x_2 =$ _____ units of quantity

[0/1/2/1 p.]

Task 8

Parameters of a Linear Function

Let $f: \mathbb{R} \rightarrow \mathbb{R}$ be a linear function with $f(x) = k \cdot x + d$ with $k, d \in \mathbb{R}$. The graph of this linear function goes through the points $A = (a, a)$ and $B = (3 \cdot a, 2 \cdot a)$, where $a \in \mathbb{R} \setminus \{0\}$.

Task:

Complete the following sentence by putting a cross next to the correct option for each gap so that the sentence becomes a true statement.

_____ ① _____ holds for the parameter k , and _____ ② _____ holds for the parameter d .

①	
$k = \frac{a}{2}$	<input type="checkbox"/>
$k = \frac{1}{2}$	<input type="checkbox"/>
$k = 2 \cdot a$	<input type="checkbox"/>

②	
$d = \frac{a}{2}$	<input type="checkbox"/>
$d = \frac{1}{2}$	<input type="checkbox"/>
$d = 2 \cdot a$	<input type="checkbox"/>

[0/1 p.]

Task 9

Amount of Water in a Swimming Pool

The linear function $V: [0, 10] \rightarrow \mathbb{R}_0^+$ models the amount of water in a swimming pool in terms of the time t (t in min, $V(t)$ in l).

The following statement holds for all $t \in [0, 9]$:

$$V(t + 1) - V(t) = -10$$

Task:

Interpret the equation above in the given context; write down the corresponding unit.

[0/1 p.]

Task 10

Oxygen

The function S assigns the temperature T of water to its maximum absorption capacity $S(T)$ of pure oxygen (T in $^{\circ}\text{C}$, $S(T)$ in mg/l). A table of values for S is shown below.

temperature T (in $^{\circ}\text{C}$)	maximum absorption capacity $S(T)$ (in mg/l)
0	14.6
20	9.1

It can be assumed that S is an exponential function.

Task:

Determine the temperature T_1 at which $S(T_1)$ is only half the value of $S(0)$.

[0/1 p.]

Task 11

Gamma Radiation

In an experiment with a radioactive compound, the intensity of the gamma radiation after penetration of three lead plates of various thicknesses (2 cm, 5 cm and 7 cm) is measured. The results are shown in the table below.

plate thickness (in cm)	2	5	7
intensity (in %)	38.94	9.46	3.69

Julian claims: "The data suggest that the intensity decreases approximately exponentially with increasing plate thickness."

Task:

Show by calculation that Julian's claim is correct.

[0/1 p.]

Task 12

Period Length

Let $f: \mathbb{R} \rightarrow \mathbb{R}$ with $f(x) = \sin(a \cdot x)$ and $g: \mathbb{R} \rightarrow \mathbb{R}$ with $g(x) = \sin\left(\frac{1}{a} \cdot x\right)$ be functions. For these functions, $a \in \mathbb{R}$ and $a > 1$.

The (smallest) period length of f is given by p_f ; the (smallest) period length of g is given by p_g .

Task:

Complete the following sentence by putting a cross next to the correct option for each gap so that the sentence becomes a true statement.

_____ ① _____ holds for p_g ; _____ ② _____ holds for $\frac{p_f}{p_g}$.

①	
$p_g = 2 \cdot \pi$	<input type="checkbox"/>
$p_g = \frac{2 \cdot \pi}{a}$	<input type="checkbox"/>
$p_g = 2 \cdot \pi \cdot a$	<input type="checkbox"/>

②	
$\frac{p_f}{p_g} = a^2$	<input type="checkbox"/>
$\frac{p_f}{p_g} = \frac{1}{a^2}$	<input type="checkbox"/>
$\frac{p_f}{p_g} = 2 \cdot \pi \cdot a^2$	<input type="checkbox"/>

[0/1 p.]

Task 13

Price Difference

A particular product costs x euros in a local shop; from an online retailer it costs y euros.
The following statement holds: $x > y > 0$

The relative proportion by which the product is more expensive in the local shop than from the online retailer is given by h .

Task:

Write down a formula in terms of x and y that could be used to calculate h .

$h =$ _____

[0/1 p.]

Task 14

Difference Quotient and Differential Quotient

The diagram below shows the graph of a 3rd degree polynomial function f .

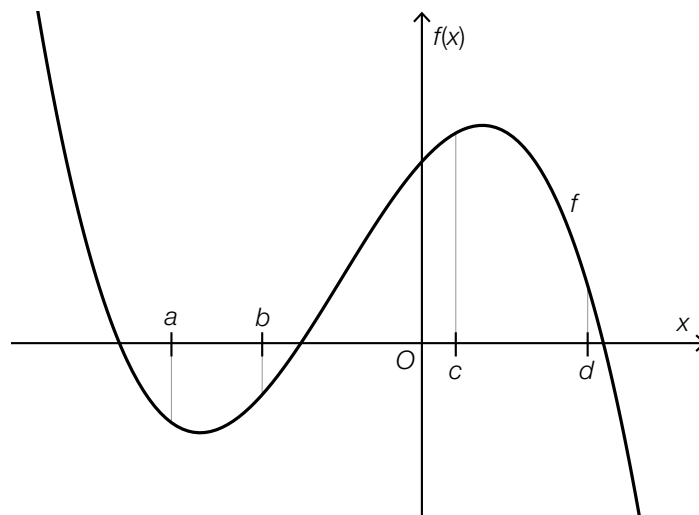

Task:

Put a cross next to each of the two statements that are true for the function f . [2 out of 5]

$\frac{f(b) - f(a)}{b - a} > 0$	<input type="checkbox"/>
$\frac{f(d) - f(c)}{d - c} > f'(c)$	<input type="checkbox"/>
$f'(b) < 0$	<input type="checkbox"/>
$\frac{f(c) - f(b)}{c - b} < 0$	<input type="checkbox"/>
$f'(d) < f'(c)$	<input type="checkbox"/>

[0/1 p.]

Task 15

Values of an Antiderivative

The diagram below shows the graph of the polynomial function f .

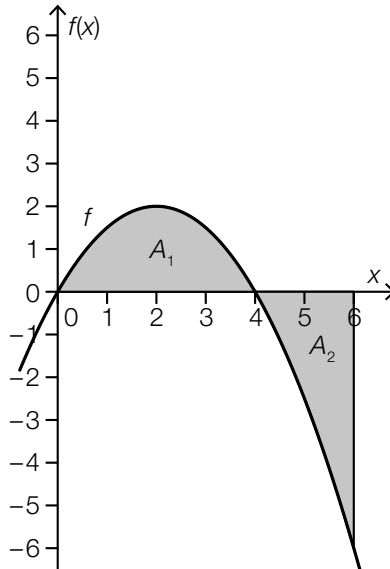

A_1 ... area of the region between the graph of f and the x -axis in the interval $[0, 4]$

A_2 ... area of the region between the graph of f and the x -axis in the interval $[4, 6]$

The following statement holds: $A_1 = A_2 = \frac{16}{3}$

For an antiderivative F of f , $F(0) = 0$ holds.

Task:

Write down the values of $F(4)$ and $F(6)$.

$F(4) =$ _____

$F(6) =$ _____

[0/1/2/1 p.]

Task 16

Derivatives of two Functions

The graphs of the two twice differentiable real functions f and g are shown below.

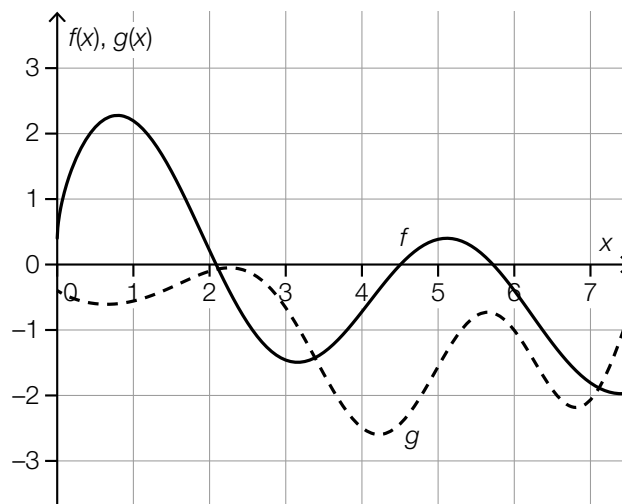

Task:

Put a cross next to each of the two correct statements. [2 out of 5]

$g'(1) > 1$	<input type="checkbox"/>
$f'(3) > g'(3)$	<input type="checkbox"/>
$f'(5) > g'(5)$	<input type="checkbox"/>
$f''(1) > g''(1)$	<input type="checkbox"/>
$f''(3) > g''(3)$	<input type="checkbox"/>

[0/1 p.]

Task 17

Definite Integral

Let f be a linear function with $f(x) = -0.5 \cdot x + a$ with $a > 0$.

$$\int_0^{x_1} f(x) dx = 0 \text{ with } x_1 > 0 \text{ holds.}$$

Task:

Write down the missing number in the equation below in the box provided.

$$x_1 = \boxed{} \cdot a$$

[0/1 p.]

Task 18

Geometric Interpretation of the Sum Rule

Let f and g be polynomial functions with $g(x) = f(x) + 2$ with $x \in [a, b]$.

The region between the graph of g and the x -axis in the interval $[a, b]$ can be divided into a subregion with area A and a subregion with area B .

The following statements hold:

$$A = \int_a^b f(x) dx \quad \text{and} \quad B = \int_a^b 2 dx$$

Task:

Draw the subregion with area A on the diagram below.

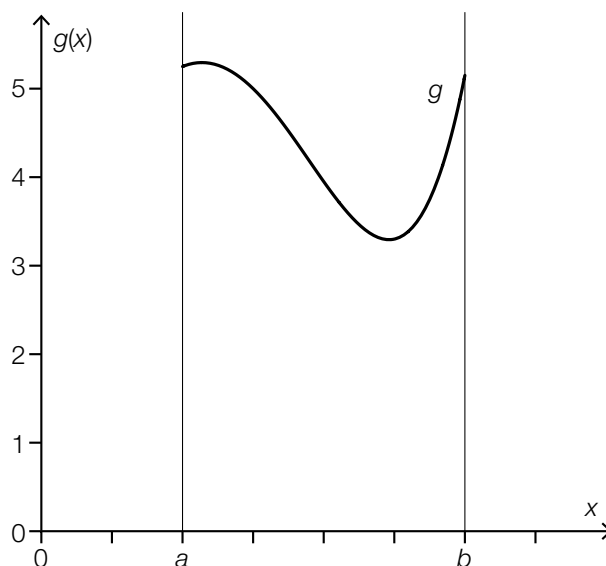

[0/1 p.]

Task 19

Email Addresses

As part of a survey, teenagers and adults were asked how many email addresses they use. The responses are summarised in the table below.

	at most 2 email addresses	more than 2 email addresses
teenagers	205	295
adults	935	565

The relative proportion of all people surveyed (teenagers and adults) who use more than 2 email addresses is given by p .

The relative proportion of the teenagers surveyed who use more than 2 email addresses is given by q .

Task:

Determine p and q .

$p =$ _____

$q =$ _____

[0/1½/1 p.]

Task 20

Statistical Parameters

The list of data x_1, x_2, \dots, x_{10} comprises 10 different numbers and is in ascending order.

Task:

Put a cross next to each of the two correct statements. [2 out of 5]

The number x_7 is the 3 rd quartile q_3 of the list of data.	<input type="checkbox"/>
The number x_3 is the 1 st quartile q_1 of the list of data.	<input type="checkbox"/>
The sum of the numbers x_1, \dots, x_{10} is 10-times as big as the mean of the list of data.	<input type="checkbox"/>
The mean of the list of data is definitely less than x_9 .	<input type="checkbox"/>
The number x_5 is the median of the list of data.	<input type="checkbox"/>

[0/1 p.]

Task 21

Football Team

The heights of the 11 players of a school football team are measured.
The collected data are listed in order of size.

- The shortest player is 1.40 m tall.
- Exactly 2 players are 1.45 m tall.
- The rest of the players are taller than 1.70 m.
- The tallest player is 1.80 m tall.

Task:

Put a cross next to each of the two correct statements. *[2 out of 5]*

The range of the collected data is 0.5 m.	<input type="checkbox"/>
The median of the collected data is greater than 1.70 m.	<input type="checkbox"/>
The mean of the collected data is greater than 1.75 m.	<input type="checkbox"/>
More than 60 % of the players are taller than 1.70 m.	<input type="checkbox"/>
Fewer than 20 % of the players are shorter than 1.50 m.	<input type="checkbox"/>

[0/1 p.]

Task 22

Balls in a Jar

There are 12 red and 15 white balls in a jar. 3 balls are removed from this jar at random without replacement.

Task:

Put a cross next to the event E whose probability can be calculated with: $P(E) = 1 - \frac{15}{27} \cdot \frac{14}{26} \cdot \frac{13}{25}$.
[1 out of 6]

At most 1 white ball is removed.	<input type="checkbox"/>
At least 1 red ball is removed.	<input type="checkbox"/>
At least 1 white ball is removed.	<input type="checkbox"/>
No white balls are removed.	<input type="checkbox"/>
At most 1 red ball is removed.	<input type="checkbox"/>
At least 2 white balls are removed.	<input type="checkbox"/>

[0/1 p.]

Task 23

Expected Values and Standard Deviations

The tables below show the respective probability distributions for the random variables X and Y with $a \in \mathbb{R}$.

random variable X :

k	$a - 2$	a	$a + 2$
$P(X = k)$	0.1	0.8	0.1

random variable Y :

k	a	$a + 2$	$a + 4$
$P(Y = k)$	0.4	0.2	0.4

Task:

Complete the sentence below by putting a cross next to one of the options for each gap so that the sentence becomes a correct statement.

_____ ① _____ holds for the expected values, and _____ ② _____ holds for the standard deviations.

①	
$E(X) < E(Y)$	<input type="checkbox"/>
$E(X) = E(Y)$	<input type="checkbox"/>
$E(X) > E(Y)$	<input type="checkbox"/>

②	
$\sigma(X) < \sigma(Y)$	<input type="checkbox"/>
$\sigma(X) = \sigma(Y)$	<input type="checkbox"/>
$\sigma(X) > \sigma(Y)$	<input type="checkbox"/>

[0/1½/1 p.]

Task 24

Experiment

An experiment is made up of n independent trials ($n \in \mathbb{N}$, $n \geq 2$). Each trial occurs under the same conditions and can only result in the two possible outcomes A and B with probabilities $P(A) = a$ and $P(B) = b$.

The probability P_1 corresponds to the event that outcome A occurs at most 2 times.

Task:

Write down an expression that could be used to calculate P_1 .

$P_1 =$ _____

[0/1 p.]

Task 1

Numbers and Sets of Numbers

Five statements about numbers and sets of numbers are stated below.

Task:

Put a cross next to each of the two true statements. [2 out of 5]

$\sqrt{\frac{9}{2}}$ is a rational number.	<input type="checkbox"/>
$-\sqrt{100}$ is an integer.	<input type="checkbox"/>
$\sqrt{15}$ is a terminating, non-recurring decimal number.	<input type="checkbox"/>
Every rational number is also a real number.	<input type="checkbox"/>
$\sqrt{-4}$ is a real number.	<input type="checkbox"/>

[0/1 p.]

Task 2

Flight Tickets

A fifth of the tickets for a particular flight are sold to private passengers; the rest are sold to travel companies.

Each ticket sold to a travel company is 5 % cheaper than a ticket sold to a private passenger.

The variable x gives the price per ticket for a private passenger.

Task:

Write down an expression that can be used to calculate the average price per ticket in terms of x .

average price per ticket: _____

[0/1 p.]

Task 3

Smoothie

The vitamin C content of blackcurrants is on average 177 mg per 100 g; the vitamin C content of kiwis is on average 46 mg per 100 g.

These two types of fruit are to be mixed in a smoothie so that a total of 75 g of smoothie contains 100 mg of vitamin C.

Task:

Determine the amount of blackcurrants (in g) and the amount of kiwis (in g) that need to be mixed for this smoothie.

[0/1 p.]

Task 4

Graphical Representation of Vectors

The diagram below shows the two vectors \vec{a} and \vec{c} as arrows starting at point P .

Task:

Starting at point P , draw the vector \vec{b} as an arrow such that $\vec{a} + \vec{b} = \vec{c}$ holds.

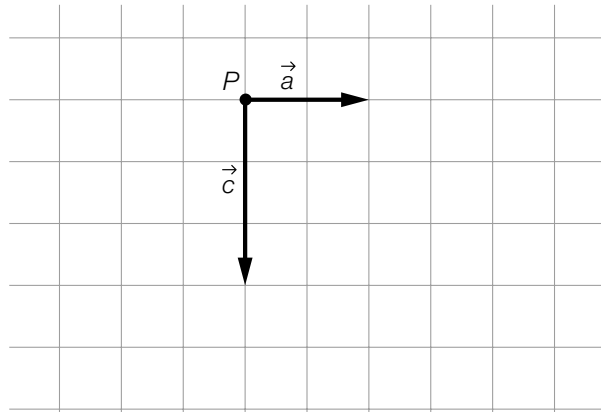

[0/1 p.]

Task 5

Equations of Lines

The lines g and h with equations $g: X = \begin{pmatrix} 1 \\ 0 \end{pmatrix} + t \cdot \begin{pmatrix} 1 \\ 1 \end{pmatrix}$ with $t \in \mathbb{R}$ and $h: X = \begin{pmatrix} 2 \\ b \end{pmatrix} + s \cdot \begin{pmatrix} a \\ 2 \end{pmatrix}$ with $s \in \mathbb{R}$ are given.

The lines g and h are identical.

Task:

Determine the real numbers a and b .

$a =$ _____

$b =$ _____

[0/1/2/1 p.]

Task 6

Triangle

The not-to-scale diagram below shows a right-angled triangle. The angles are measured in degrees and the side lengths in cm.

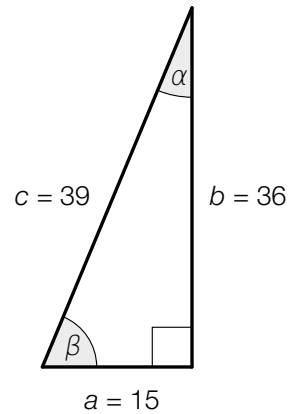

Task:

Put a cross next to each of the two correct statements. [2 out of 5]

$\sin(\alpha) = \frac{5}{13}$	<input type="checkbox"/>
$\cos(\beta) = \frac{5}{12}$	<input type="checkbox"/>
$\tan(\alpha) = \frac{12}{5}$	<input type="checkbox"/>
$\sin(90^\circ - \beta) = \frac{15}{36}$	<input type="checkbox"/>
$\cos(90^\circ - \alpha) = \frac{15}{39}$	<input type="checkbox"/>

[0/1 p.]

Task 7

Graph of a Polynomial Function

A fourth-degree polynomial function f has the following properties:

- f has a local maximum when $x = -3$.
- The graph of f is symmetrical about the vertical axis.

Task:

In the coordinate system shown below, sketch the graph of one such polynomial function f in the interval $[-4, 4]$.

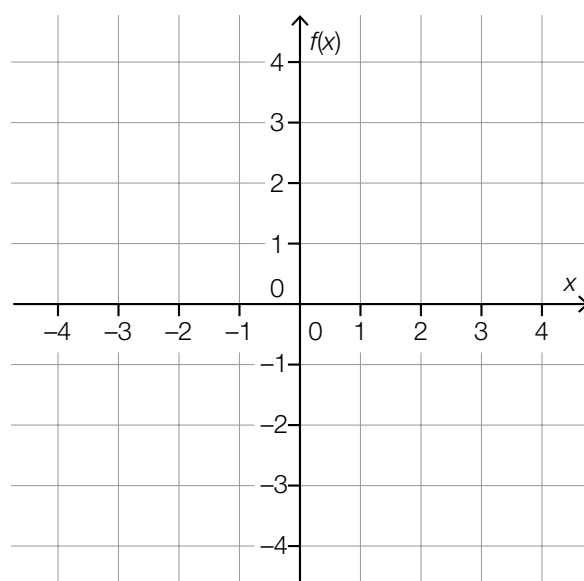

[0/1 p.]

Task 8

Length of a Candle

A cylindrical candle has a length of 10 cm at time $t = 0$. After burning for 120 min, the candle has a length of 4 cm.

The linear function L models the length of the candle in terms of the burning time t with $0 \leq t \leq 200$ (t in min, $L(t)$ in cm).

Task:

Write down an equation of the function L .

[0/1 p.]

Task 9

Parameters of a Quadratic Function

The graph of the quadratic function f with equation $f(x) = a \cdot x^2 + b$ has a local minimum at point $S = (0, -2)$ and goes through the point $P = (1, 0)$.

Task:

Determine the real parameters a and b .

$a =$ _____

$b =$ _____

[0/1½/1 p.]

Task 10

Zeros, Maxima, Minima and Points of Inflexion

The number of real zeros, local maxima and minima and points of inflexion of a polynomial function depends on the degree of the function, among other things.

Task:

Put a cross next to each of the two correct statements. [2 out of 5]

Every 1 st degree polynomial function has exactly 1 local maximum or minimum.	<input type="checkbox"/>
Every 2 nd degree polynomial function has at least 1 real zero.	<input type="checkbox"/>
Every 3 rd degree polynomial function has at least 1 real zero.	<input type="checkbox"/>
Every 4 th degree polynomial function has exactly 3 local maxima or minima.	<input type="checkbox"/>
Every 5 th degree polynomial function has at least 1 point of inflexion.	<input type="checkbox"/>

[0/1 p.]

Task 11

Annual Interest Rate

The capital K_0 grows exponentially under a consistent annual interest rate i .

After n years, the capital reaches the value K_n , which can be calculated with the formula shown below.

$$K_n = K_0 \cdot (1 + i)^n \quad \text{with } n \in \mathbb{N}$$

After 6 years, the capital K_0 has increased by a total of 8.62 %.

Task:

Determine the annual interest rate i .

[0/1 p.]

Task 12

Windmill

The tips of the rotor blades of windmills move in a circle whose diameter is known as the *rotor diameter*.

The function $h: \mathbb{R} \rightarrow \mathbb{R}, t \mapsto h(t)$ models the height of the tip of one of the rotor blades of a particular windmill above the ground in terms of the time t (t in s, $h(t)$ in m).

The graph of the function h is shown in the diagram below.

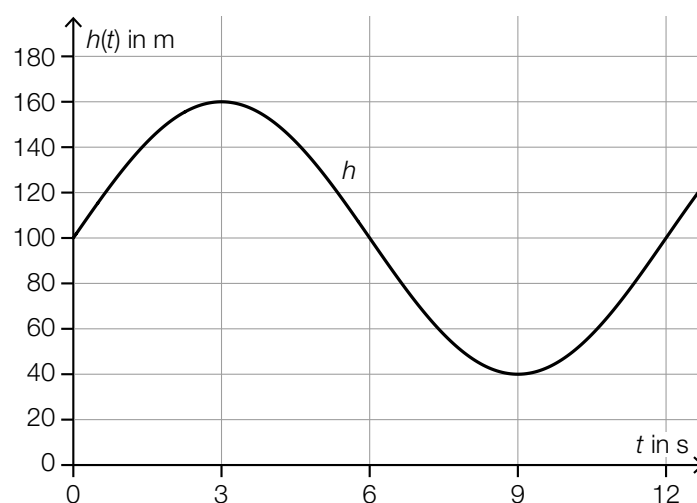

Task:

Using the diagram above, write down the rotor diameter as well as the time that a rotor blade requires for a full revolution.

rotor diameter: _____ m

time for a full revolution: _____ s

[0/1/2/1 p.]

Task 13

Gradient of a Tangent

The function $f: \mathbb{R} \rightarrow \mathbb{R}$ is an n^{th} degree polynomial function with $n \geq 2$.

Task:

Put a cross next to each of the two limits that, in all cases, correspond to the gradient of the tangent of the graph of the function f at $x = 5$. [2 out of 5]

$\lim_{x_1 \rightarrow 5} \frac{f(x_1) - f(5)}{5 - x_1}$	<input type="checkbox"/>
$\lim_{h \rightarrow 0} \frac{f(5 + h) - f(5)}{5 + h}$	<input type="checkbox"/>
$\lim_{h \rightarrow 5} \frac{f(5 + h) - f(5)}{h}$	<input type="checkbox"/>
$\lim_{x_1 \rightarrow 5} \frac{f(x_1) - f(5)}{x_1 - 5}$	<input type="checkbox"/>
$\lim_{h \rightarrow 0} \frac{f(5 + h) - f(5)}{h}$	<input type="checkbox"/>

[0/1 p.]

Task 14

Cyclist

The differentiable function $v: \mathbb{R}_0^+ \rightarrow \mathbb{R}_0^+$, $t \mapsto v(t)$ models the velocity of a cyclist on her journey to school in terms of the time (t in s, $v(t)$ in m/s).

For all $t \in [0, 6]$, $v'(t) > 0$ holds.

Task:

Describe the meaning of the inequality shown in the given context.

[0/1 p.]

Task 15

Production Costs

The monthly fixed costs of a business for the production of soft drinks are € 200,000.

The function K models the total monthly costs for this production (in euros) in terms of the amount produced x .

The marginal costs for this production are described by the function K' .

$$K'(x) = 0.003 \cdot x^2 - 6 \cdot x + 3500$$

x ... amount produced in units of quantity

$K'(x)$... marginal costs for the amount produced x in euros per unit of quantity

Task:

Write down an equation of the function K .

$K(x) =$ _____

[0/1 p.]

Task 16

Derivative

The diagram below shows the graph of the constant derivative function f' of a function f . For this function f , the statement $f(0) = 2$ holds.

Task:

Draw the graph of the function f on the diagram below.

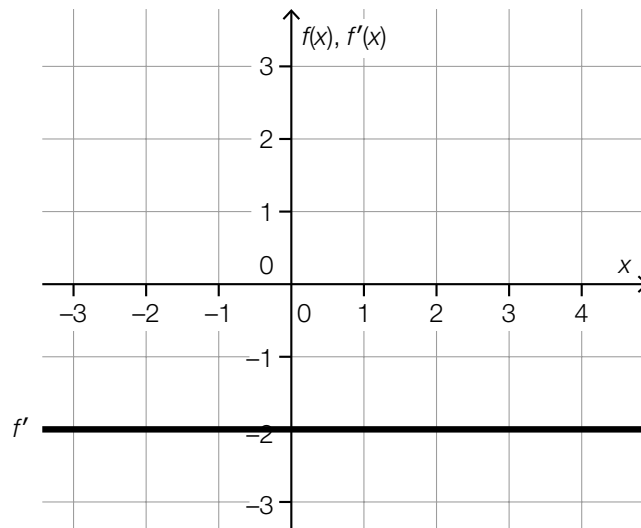

[0/1 p.]

Task 17

Points on a Graph

The graph of a 3rd degree polynomial function f is shown below.

Four points with x -coordinates 0 , x_1 , x_2 and x_3 are also displayed. These four points are characteristic points of the graph (points of intersection with the axes, maxima or minima, point of inflexion).

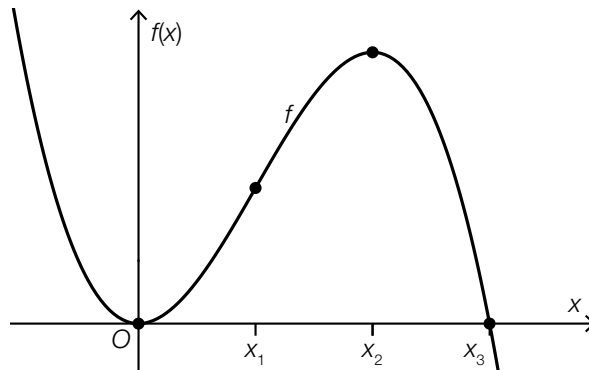

Task:

Match each of the four x -coordinates 0 , x_1 , x_2 and x_3 to the corresponding statement from A to F.

0	
x_1	
x_2	
x_3	

A	At the point with this x -coordinate, the first derivative is zero and the second derivative is negative.
B	At the point with this x -coordinate, the first and the second derivatives are negative.
C	At the point with this x -coordinate, the first derivative is zero and the second derivative is positive.
D	At the point with this x -coordinate, the first and the second derivatives are positive.
E	At the point with this x -coordinate, the first and the second derivatives are zero.
F	At the point with this x -coordinate, the first derivative is positive and the second derivative is zero.

[0/1½/1 p.]

Task 18

Area

The graph of the function $f: \mathbb{R} \rightarrow \mathbb{R}$ with integer zeros is shown below.

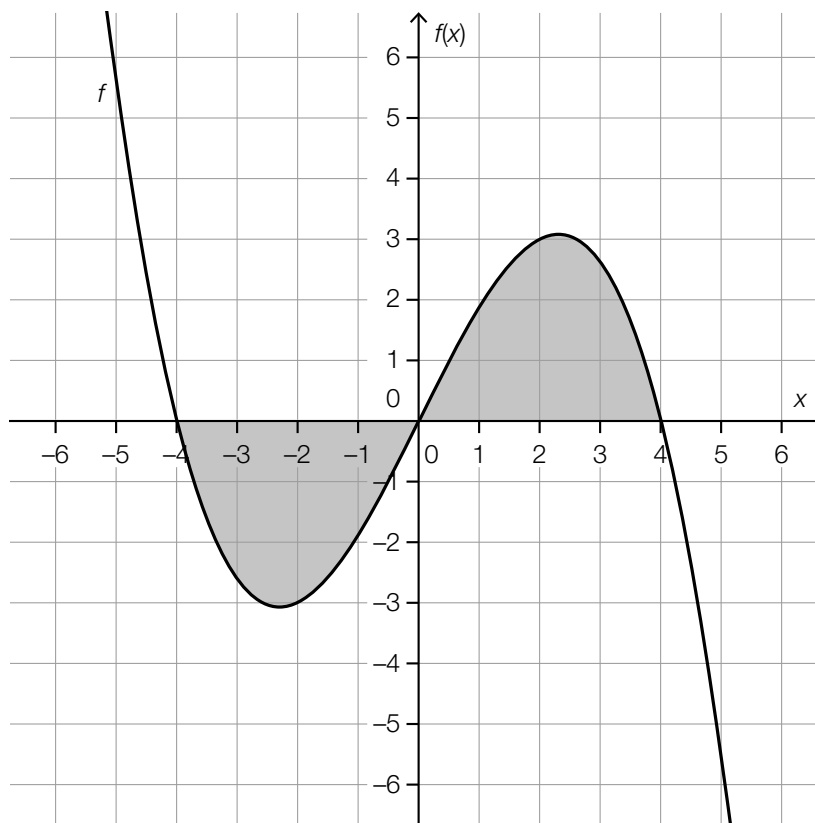

The areas of each of the two regions shaded grey are of equal size.

Task:

Put a cross next to each of the two expressions with which the total area of the regions shaded grey can be calculated. [2 out of 5]

$2 \cdot \int_0^4 f(x) dx$	<input type="checkbox"/>
$\int_0^4 f(x) dx - \int_{-4}^0 f(x) dx$	<input type="checkbox"/>
$2 \cdot \int_{-4}^0 f(x) dx$	<input type="checkbox"/>
$\int_{-4}^0 f(x) dx - \int_0^4 f(x) dx$	<input type="checkbox"/>
$\left \int_{-4}^4 f(x) dx \right $	<input type="checkbox"/>

Task 19

Monthly Wages

A particular company has two departments.

In the first department, there are 14 employees, and in the second department there are 26 employees.

The following information is known about the monthly wages of the employees:

- The mean of the monthly wages of all 40 employees is € 2,280.50.
- The mean of the monthly wages of the employees of the second department is € 2,200.00.

Task:

Determine the mean \bar{x} of the monthly wages of the employees of the first department.

$\bar{x} = €$ _____

[0/1 p.]

Task 20

Random Experiment

A particular random experiment results in either “success” or “failure”. The random variable X gives the number of times the experiment results in “success” if the random experiment is conducted 7 times.

Task:

Match each of the four probabilities to the corresponding equal probability from A to F.

$P(X < 3)$	
$P(X \leq 3)$	
$P(X \geq 3)$	
$P(X > 3)$	

A	$P(X > 2)$
B	$1 - P(X \leq 4)$
C	$P(X \leq 2)$
D	$P(X = 3) + P(X > 4)$
E	$P(X = 4) + P(X \geq 5)$
F	$1 - P(X > 3)$

[0/1½/1 p.]

Task 21

Card Game

The following statements hold for the 8 cards of a card game:

- 3 cards are labelled with “1”.
- 3 cards are labelled with “2”.
- 2 cards are labelled with “3”.

These 8 cards are shuffled. Then, 2 cards are dealt.

Task:

Determine the probability that at least 1 of the 2 cards dealt is labelled with an odd number.

[0/1 p.]

Task 22

Bit Combinations

A computer calculates with so-called *bits*. A bit can either take the value 0 or the value 1. An arbitrary array of eight bits is also known as a *byte*.

Task:

Put a cross next to the correct interpretation of $\binom{8}{3}$ in the given context. [1 out of 6]

$\binom{8}{3}$ gives the probability that the first three bits of a byte are all 1s.	<input type="checkbox"/>
$\binom{8}{3}$ gives the probability that exactly three 1s appear in a row in a byte.	<input type="checkbox"/>
$\binom{8}{3}$ gives the probability that there are exactly three 1s in a byte.	<input type="checkbox"/>
$\binom{8}{3}$ gives the number of possibilities for there being exactly three 1s in a byte.	<input type="checkbox"/>
$\binom{8}{3}$ gives the number of possibilities for exactly three 1s to appear in a row in a byte.	<input type="checkbox"/>
$\binom{8}{3}$ gives the number of possibilities for the first three bits of a byte to all be 1s.	<input type="checkbox"/>

[0/1 p.]

Task 23

Wheel of Fortune

A pointer is mounted in the middle of the wheel of fortune shown below. For each revolution of the pointer, the following statement holds:

The pointer lands in each sector with probability $\frac{1}{8}$.

The winning sums to be paid out when the pointer lands in the various sectors are shown on the wheel of fortune below ($a \in \mathbb{R}^+$).

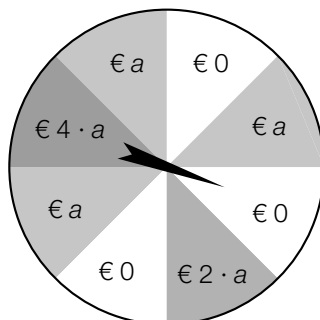

The pointer is spun once.

The random variable X gives the amount of the winning sum to be paid out.

The expectation value in euros is given as: $E(X) = 4.5$

Task:

Determine a .

[0/1 p.]

Task 24

Binomial Distribution

The five random variables X_1, X_2, X_3, X_4 and X_5 can only take integer values between 0 and 8. Their probability distributions are shown in the diagrams below.

Task:

Put a cross next to the two diagrams that could show a binomial distribution.

[2 out of 5]

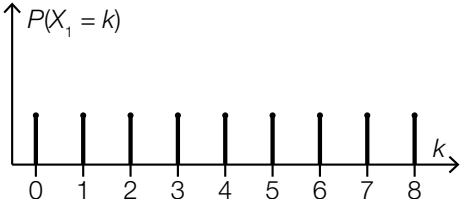
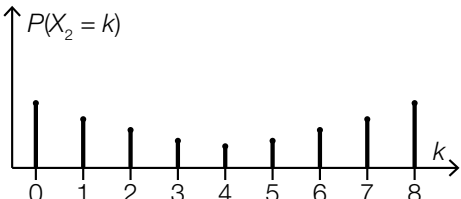
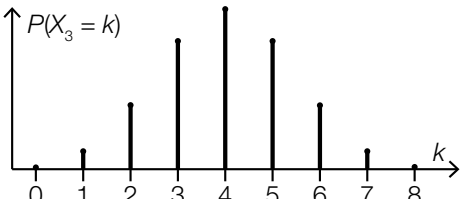
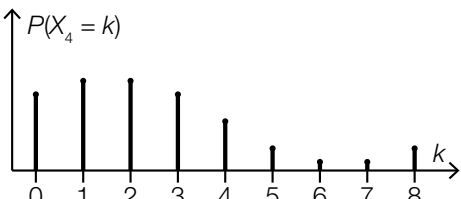
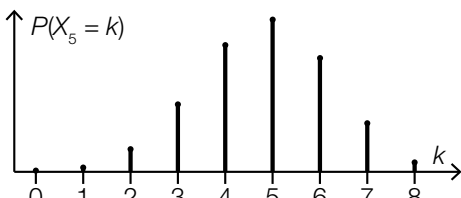
	<input type="checkbox"/>
	<input type="checkbox"/>
	<input type="checkbox"/>
	<input type="checkbox"/>
	<input type="checkbox"/>

[0/1 p.]

Task 1

Integers and Irrational Numbers

Four properties of numbers as well as six numbers are shown below.

Task:

Match each of the four properties of numbers to the number with this property from A to F.

negative integer	
negative irrational number	
positive integer	
positive irrational number	

A	$2 - \sqrt{10}$
B	10^{-2}
C	$-\sqrt{10^2}$
D	$2 \div (-10)$
E	$\sqrt{10} \div 2$
F	$(-\sqrt{10})^2$

[0/1/2/1 p.]

Task 2

Taxi Journey

A particular taxi company sets their daily rate as follows:

In addition to the predetermined base fare G , a charge K is to be paid per kilometre of distance travelled.

For a journey that starts at night between 22:00 and 6:00, an extra charge of 30 % of the daily rate is to be paid.

A passenger gets into a taxi from this taxi company at 22:00 and covers a distance of S kilometres.

Task:

Write down an equation that can be used to calculate the total travel costs F for this journey. Write the equation in terms of G , S and K .

$F =$ _____

[0/1 p.]

Task 3

Apple Juice and Orange Juice

At an event, the only drinks that are sold are apple juice and orange juice in cups.

In total, 375 cups are sold at the event, of which a cups contain apple juice at € 0.80 each and b cups contain orange juice at € 1.00 each.

The revenue earned from these sales is € 339.00.

Task:

Write down a system of equations that can be used to calculate a and b .

I: _____

II: _____

[0/1/2/1 p.]

Task 4

Cuboid

The diagram below shows a cuboid $ABCDEFGH$ in a three-dimensional coordinate system. The lengths of the edges of the cuboid can be read from the diagram (lengths in centimetres).

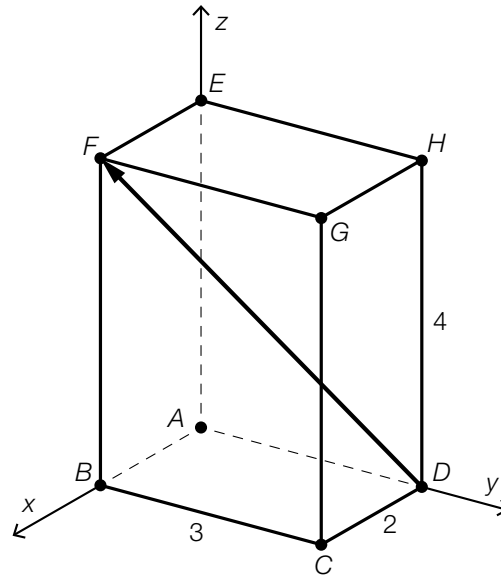

Task:

Write down the coordinates of the vector \overrightarrow{DF} .

$$\overrightarrow{DF} = \begin{pmatrix} \square \\ \square \\ \square \end{pmatrix}$$

[0/1 p.]

Task 5

Vector and Line

The diagram below shows the points A and B as well as the line $g: y = x$.

The points A and B have integer coordinates.

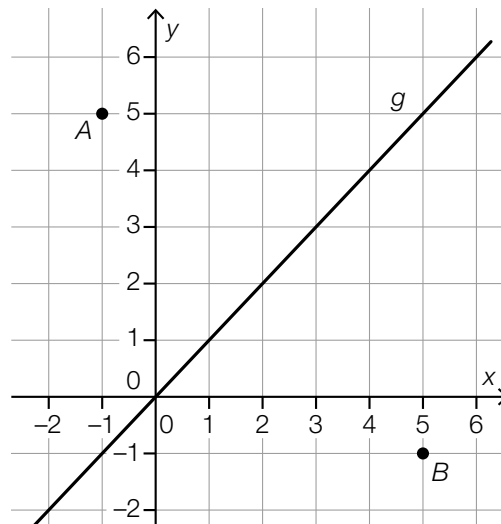

Task:

Show by calculation that the vector \overrightarrow{AB} is perpendicular to the line g .

[0/1 p.]

Task 6

Triangle

The diagram below shows a right-angled triangle ABC .

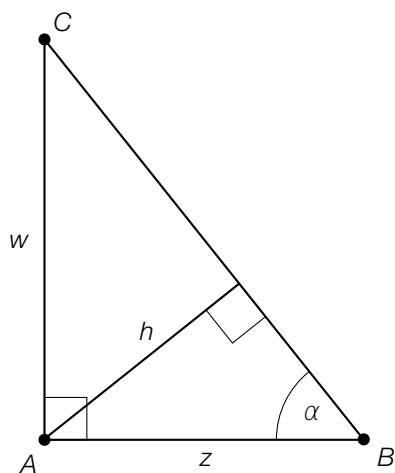

Task:

Put a cross next to the equation that is definitely true. [1 out of 6]

$h = \frac{w}{\sin(\alpha)} \cdot \cos(\alpha)$	<input type="checkbox"/>
$h = \frac{w}{\cos(\alpha)} \cdot \sin(\alpha)$	<input type="checkbox"/>
$h = \frac{w}{\sin(\alpha)} \cdot \tan(\alpha)$	<input type="checkbox"/>
$h = \frac{w}{\tan(\alpha)} \cdot \sin(\alpha)$	<input type="checkbox"/>
$h = \frac{\sin(\alpha)}{w} \cdot \tan(\alpha)$	<input type="checkbox"/>
$h = \frac{\sin(\alpha)}{w} \cdot \cos(\alpha)$	<input type="checkbox"/>

[0/1 p.]

Task 7

Exponential Functions

Let $f: \mathbb{R} \rightarrow \mathbb{R}$ be an exponential function of the form $f(x) = a \cdot b^x$ with $a, b \in \mathbb{R}$ with $a, b > 0$ and $b \neq 1$.

Task:

Put a cross next to each of the two statements that are true about every exponential function of the form given above. [2 out of 5]

f has no zeros.	<input type="checkbox"/>
f is strictly monotonically increasing.	<input type="checkbox"/>
f has at least one local extremum (maximum or minimum).	<input type="checkbox"/>
The graph of f is concave up.	<input type="checkbox"/>
For $x \rightarrow \infty$, the graph of f tends towards the positive x-axis.	<input type="checkbox"/>

[0/1 p.]

Task 8

Acceleration

A vehicle moves forwards at a velocity of 20 m/s along a straight path.

At time $t = 0$, it accelerates uniformly at 3 m/s^2 for 5 s. The direction of the movement remains unchanged.

The function v describes the velocity of the vehicle (in m/s) after t seconds in the time interval $[0, 5]$.

Task:

In the coordinate system shown below, draw the graph of v .

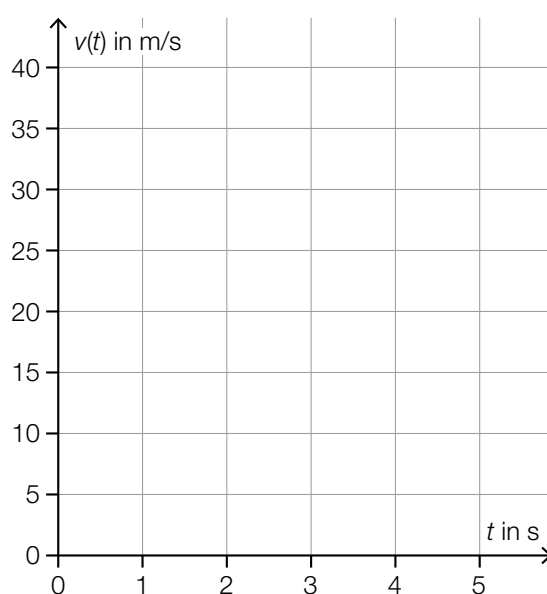

[0/1 p.]

Task 9

Quadratic Function

Let f be a quadratic function of the form $f(x) = a \cdot x^2 + b$ with $a, b \in \mathbb{R} \setminus \{0\}$.

Task:

Write down a condition that the parameters a and b must satisfy such that f has two real zeros.

[0/1 p.]

Task 10

Number of Zeros of a Polynomial Function

There is a relationship between the number of possible real zeros and the degree of a polynomial function.

Task:

Complete the gaps in the following sentence by putting a cross next to one of the given possibilities for each gap so that the sentence becomes a correct statement.

Every _____^①_____ degree polynomial function has _____^②_____ one real zero.

①	
second	<input type="checkbox"/>
third	<input type="checkbox"/>
fourth	<input type="checkbox"/>

②	
exactly	<input type="checkbox"/>
at least	<input type="checkbox"/>
more than	<input type="checkbox"/>

[0/1 p.]

Task 11

Doubling Time

The number of bacteria in each of six bacterial cultures grows exponentially. Each of the corresponding doubling times is different.

The number of bacteria in each bacterial culture is modelled in terms of time t by $N_i: \mathbb{R}_0^+ \rightarrow \mathbb{R}^+, t \mapsto N_i(t)$ with $i \in \{1, 2, \dots, 6\}$ (t in hours).

Task:

Match each of the four statements about the doubling times to the corresponding equation of a function from A to F.

The number of bacteria doubles once an hour.	
The number of bacteria doubles twice an hour.	
The number of bacteria doubles 3 times an hour.	
The number of bacteria doubles 4 times an hour.	

A	$N_1(t) = N_1(0) \cdot 1.5^t$
B	$N_2(t) = N_2(0) \cdot 4^t$
C	$N_3(t) = N_3(0) \cdot 2^t$
D	$N_4(t) = N_4(0) \cdot 16^t$
E	$N_5(t) = N_5(0) \cdot 3^t$
F	$N_6(t) = N_6(0) \cdot 8^t$

[0/1/2/1 p.]

Task 12

Period Length

Let $f: \mathbb{R} \rightarrow \mathbb{R}$ be a function with $f(x) = \sin\left(\frac{\pi}{c} \cdot x\right)$ with $c \in \mathbb{R}^+$.

The (shortest) period length of f is $\frac{3}{2}$.

Task:

Determine c .

[0/1 p.]

Task 13

Bitcoin

Bitcoin is a digital artificial currency. On 17.12.2017, the exchange rate per bitcoin was € 16,198.60.

The table below shows the exchange rate per bitcoin over the course of a year.

date	exchange rate per bitcoin
17.12.2017	€ 16,198.60
17.03.2018	€ 6,422.98
17.06.2018	€ 5,571.62
17.09.2018	€ 5,362.46
17.12.2018	€ 3,145.20

During one of the three-month time periods, the value of the absolute change in the exchange rate was the greatest.

Task:

Determine the relative change of the exchange rate of bitcoin in this time period.

relative change: _____

[0/1 p.]

Task 14

Average Speed

The movement of a particular body is modelled by the distance-time function s with $s(t) = d \cdot t^2$ (t in s, $s(t)$ in m).

The average speed of this body in the time interval $[0 \text{ s}, 2 \text{ s}]$ is 10 m/s.

Task:

Determine d .

[0/1 p.]

Task 15

Antiderivative of a Sine Function

The function $F: \mathbb{R} \rightarrow \mathbb{R}$ with $F(x) = -1.25 \cdot \cos(b \cdot x)$ is an antiderivative of the function $f: \mathbb{R} \rightarrow \mathbb{R}$ with $f(x) = 2 \cdot \sin(b \cdot x)$ with $b \in \mathbb{R} \setminus \{0\}$.

Task:

Determine b .

[0/1 p.]

Task 16

Value of a Definite Integral

The function g is an antiderivative of the polynomial function f . Some pairs of values of the function g are shown below:

x	$g(x)$
-2	3
-1	0
0	-1
1	0
2	3
3	8
4	15

Task:

Write down the value of the integral shown below.

$$\int_0^3 f(x) dx = \underline{\hspace{15em}}$$

[0/1 p.]

Task 17

Properties of a Polynomial Function

A 4th degree polynomial function f has a local maximum at each of the x -coordinates $a \in \mathbb{R}$ and $b \in \mathbb{R}$ with $a < b$. Six statements about $c \in \mathbb{R}$ with $a < c < b$ are shown below.

Task:

Put a cross next to the statement that is definitely true. [1 out of 6]

There is exactly one c for which $f'(c) = 0$ holds.	<input type="checkbox"/>
There is exactly one c for which $f''(c) = 0$ holds.	<input type="checkbox"/>
There is no c for which $f(c) = 0$ holds.	<input type="checkbox"/>
There is no c for which $f'(c) = 0$ holds.	<input type="checkbox"/>
There is exactly one c for which $f(c) = 0$ holds.	<input type="checkbox"/>
There is no c for which $f'''(c) = 0$ holds.	<input type="checkbox"/>

[0/1 p.]

Task 18

Integral and Area

The diagram below shows the graph of the function f , which crosses the x -axis at 0 , a , b and c . The graph of f and the x -axis bound three regions with areas $A_1 = 17$, $A_2 = 50$ and $A_3 = 2$.

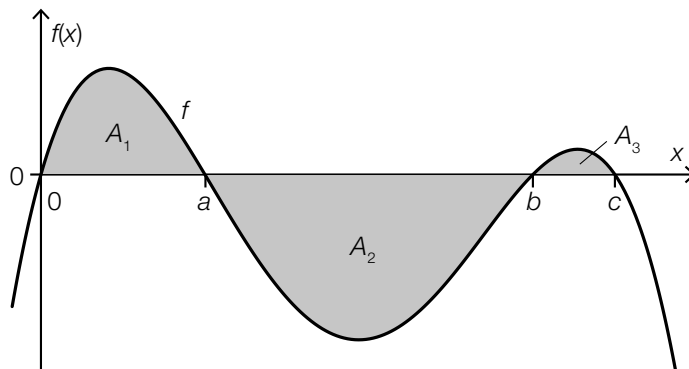

Task:

Match each of the four expressions to the corresponding value from A to F.

$\int_0^c f(x) dx$	
$\int_0^a f(x) dx + \int_a^b f(x) dx$	
$\int_0^a f(x) dx - \int_a^b f(x) dx + \int_b^c f(x) dx$	
$\int_a^c f(x) dx + 100$	

A	-31
B	69
C	-33
D	52
E	67
F	152

[0/1/2/1 p.]

Task 19

List of Data

A list of data with n natural numbers ($n \in \mathbb{N}$, $n \geq 2$) is given.

Task:

Complete the gaps in the following sentence by putting a cross next to one of the given possibilities for each gap so that the sentence becomes a correct statement.

If all the values of the list of data are increased by a ($a \in \mathbb{R}^+$), then _____^① also increases by a , while _____^② remains unchanged.

①	
the range	<input type="checkbox"/>
the median	<input type="checkbox"/>
the variance	<input type="checkbox"/>

②	
the mean	<input type="checkbox"/>
the mode	<input type="checkbox"/>
the standard deviation	<input type="checkbox"/>

[0/1/2/1 p.]

Task 20

Number of Births

The following sentence about a particular region appears in a local newspaper:

“In 2019, the number of births in the region was higher than the average value in the 4-year period from 2015 to 2018.”

Task:

Put a cross next to each of the two statements that are definitely true according to the sentence above. [2 out of 5]

The number of births in 2019 was higher than in each year of the period from 2015 to 2018.	<input type="checkbox"/>
The total number of births in the period from 2015 to 2018 was lower than four times the number of births in 2019.	<input type="checkbox"/>
The number of births in at least one year in the period from 2015 to 2018 was higher than in 2019.	<input type="checkbox"/>
The number of births in at most three years in the period from 2015 to 2018 was higher than in 2019.	<input type="checkbox"/>
The number of births in at least two years in the period from 2015 to 2018 was lower than in 2019.	<input type="checkbox"/>

[0/1 p.]

Task 21

Game

The probability of winning 1 round of a particular game has the value p .

The probability of winning 2 consecutive rounds of this game has the value p_1 .

Consecutive rounds are independent of each other.

Task:

Put a cross next to each of the two statements that are definitely true about the game described above. [2 out of 5]

$p_1 = 2 \cdot p$	<input type="checkbox"/>
$p_1 = (1 - p)^2$	<input type="checkbox"/>
$p_1 = p \cdot (1 - p)$	<input type="checkbox"/>
$p_1 \leq p$	<input type="checkbox"/>
$p_1 = p^2$	<input type="checkbox"/>

[0/1 p.]

Task 22

Ice Cream Parlour

In an ice cream parlour, 24 flavours of ice cream are sold.

Task:

Write down the number of possible ways of choosing 3 different flavours of ice cream out of the 24 flavours sold. (The order of the choices is not to be considered.)

[0/1 p.]

Task 23

Probability of an Event

A random experiment is conducted n times ($n \in \mathbb{N}$ with $n \geq 12$).

The random variable X corresponds to how often a particular event occurs in these n experiments.

The probability that this event occurs at least 10 times is 35 %.

Task:

Put a cross next to each of the two statements that are definitely true. [2 out of 5]

$P(X = 0) = 0$	<input type="checkbox"/>
$P(X \leq 10) = 0.35$	<input type="checkbox"/>
$P(X < 9) \leq 0.65$	<input type="checkbox"/>
$P(X \geq 10) = 0.35$	<input type="checkbox"/>
$P(X > 11) > 0.4$	<input type="checkbox"/>

[0/1 p.]

Task 24

Quality Assurance

As part of the quality assurance in the production of porcelain figures, the figures are checked for faults once they are finished. It is known from experience that 2 % of the porcelain figures are faulty.

A random sample of n porcelain figures is taken ($n \in \mathbb{N}$ with $n \geq 2$). The number of faulty porcelain figures is assumed to be binomially distributed.

The event that at least 1 of the n porcelain figures is faulty is given by E .

Task:

Write down a formula in terms of n that can be used to calculate the probability $P(E)$.

$P(E) =$ _____

[0/1 p.]

Task 1

Linear Equation

An equation in the variable $x \in \mathbb{Z}$ is shown below:

$$2 \cdot x - c = 0 \quad \text{with } c \in \mathbb{R}$$

Task:

Write down all real numbers c for which this equation has a solution in \mathbb{Z} .

[0/1 p.]

Task 2

Donations

Anton donates an amount of a euros to each of 3 research institutes and an amount of $(a + 10)$ euros to each of 5 animal welfare organisations.

Task:

Write down the average amount G (in euros) that Anton has donated in terms of a .

$G =$ _____ euros

[0/1 p.]

Task 3

Force and Acceleration

If a force acts on a body at rest, this body accelerates in the direction of the force. The absolute value of the force is given by $F = m \cdot a$, where m is the mass and a is the acceleration of the body (F in Newtons (N), m in kg, a in m/s^2).

A force of $F_1 = 5 \text{ N}$ acts on a particular sphere at rest. This sphere thus accelerates at a rate of $a_1 = 0.625 \text{ m/s}^2$. A second sphere at rest with the same mass is acted on by a force F_2 so that this sphere accelerates at a rate of $a_2 = 0.5 \text{ m/s}^2$.

Task:

Determine F_2 in N.

[0/1 p.]

Task 4

Position of a Ship

A ship travels with constant velocity along a straight path on a particular day from 8:10 am to 8:30 am.

In a Cartesian coordinate system, the position of this ship at 8:10 am is given by the point $A = (2, 3)$; its position at 8:30 am is given by the point $B = (10, 5)$.

The vector \vec{s} gives the change in the position of this ship in a time period of 5 minutes.

Task:

Write down the components of the vector \vec{s} .

$$\vec{s} = \begin{pmatrix} \square \\ \square \end{pmatrix}$$

[0/1 p.]

Task 5

Parallel Vector

The vector $\vec{a} = \begin{pmatrix} 2 \\ -1 \\ 3 \end{pmatrix}$ is given.

A vector \vec{b} is parallel to the vector \vec{a} and has a greater length than \vec{a} .

Task:

Write down the components of a possible vector \vec{b} .

$$\vec{b} = \begin{pmatrix} \square \\ \square \\ \square \end{pmatrix}$$

[0/1 p.]

Task 6

Sailing Boat

A model of a sailing boat is shown in the diagram below.

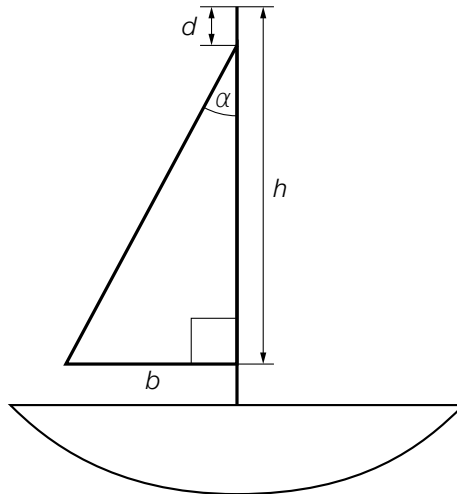

Task:

Write down a formula in terms of h , d and b that can be used to calculate the size of the angle α .

$\alpha =$ _____

[0/1 p.]

Task 7

Monotonicity and Concavity of a Polynomial Function

The graph of a 3rd degree polynomial function f is shown below. All the characteristic points of this graph (intersections with the axes, maxima, minima, points of inflexion) have integer coordinates.

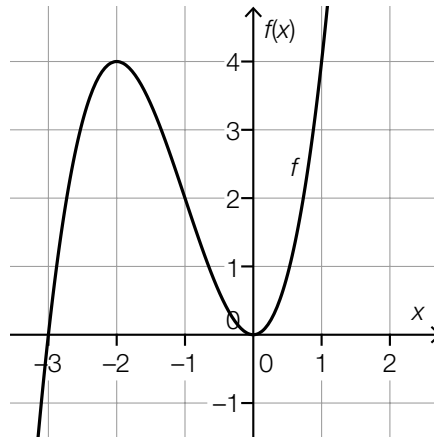

Task:

Complete the gaps in the following sentence by putting a cross next to one of the given possibilities for each gap so that the sentence becomes a correct statement.

The function f is strictly monotonically increasing in the interval $\text{\textcircled{1}}$ and its concavity changes when $\text{\textcircled{2}}$.

\text{\textcircled{1}}	
$(-\infty, -2)$	<input type="checkbox"/>
$(-1, 1)$	<input type="checkbox"/>
$(-2, 0)$	<input type="checkbox"/>

\text{\textcircled{2}}	
$x = -2$	<input type="checkbox"/>
$x = -1$	<input type="checkbox"/>
$x = 0$	<input type="checkbox"/>

[0/1/2/1 p.]

Task 8

Swimming Pool

Water is let out of a swimming pool.

The function $h: [0, 6] \rightarrow \mathbb{R}$ with $h(t) = 180 - 30 \cdot t$ models the height of the surface of the water in terms of the time t (t in h, $h(t)$ in cm).

Task:

Interpret the coefficients 180 and -30 in the given context with the corresponding units.

180: _____

-30 : _____

[0/1/2/1 p.]

Task 9

Graph of a Quadratic Function

The graph of a function $f: \mathbb{R} \rightarrow \mathbb{R}$ of the form $f(x) = a \cdot x^2 + b$ with $a, b \in \mathbb{R}$ is shown below.

For a function $g: \mathbb{R} \rightarrow \mathbb{R}$ of the form $g(x) = c \cdot x^2 + d$ with $c, d \in \mathbb{R}$, the following statements hold: $c < -a$ and $d > b$

Task:

On the diagram below, sketch the graph of one such function g .

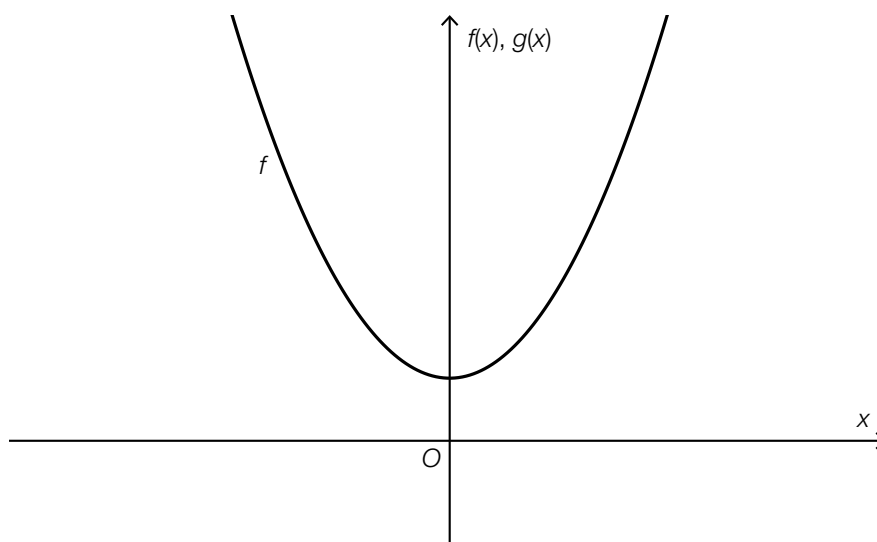

[0/1 p.]

Task 10

Number of Zeros, Maxima, Minima and Points of Inflexion

Let f be a 4th degree polynomial function.

Statements about the exact number of distinct zeros, local extrema (maxima or minima), and points of inflexion are shown below.

Task:

Put a cross next to each of the two statements that could be true about f . [2 out of 5]

The function f can have 0 real zeros, 1 local extremum (maximum or minimum) and 0 points of inflexion.	<input type="checkbox"/>
The function f can have 1 real zero, 3 local extrema (maxima or minima) and 2 points of inflexion.	<input type="checkbox"/>
The function f can have 2 distinct real zeros, 2 local extrema (maxima or minima) and 2 points of inflexion.	<input type="checkbox"/>
The function f can have 3 distinct real zeros, 2 local extrema (maxima or minima) and 0 points of inflexion.	<input type="checkbox"/>
The function f can have 4 distinct real zeros, 3 local extrema (maxima or minima) and 1 point of inflexion.	<input type="checkbox"/>

[0/1 p.]

Task 11

Video Views

A video is uploaded to an internet platform. At the beginning of the observations, the video had 500 views. In the time period $[0, t_1]$, the number of views is described by an exponential function.

The table below shows pairs of values of this exponential function.

time since the beginning of the observations in h	number of views
0	500
1	700
2	980
3	1 372
t_1	10 330

Task:

Determine t_1 .

[0/1 p.]

Task 12

Sine Functions

Four graphs of functions of the form $f(x) = a \cdot \sin(b \cdot x)$ with $a \in \mathbb{R}$ and $b \in \mathbb{R}^+$ are shown in the diagrams below.

Task:

Match each of the four graphs to the corresponding condition for a and b from A to F.

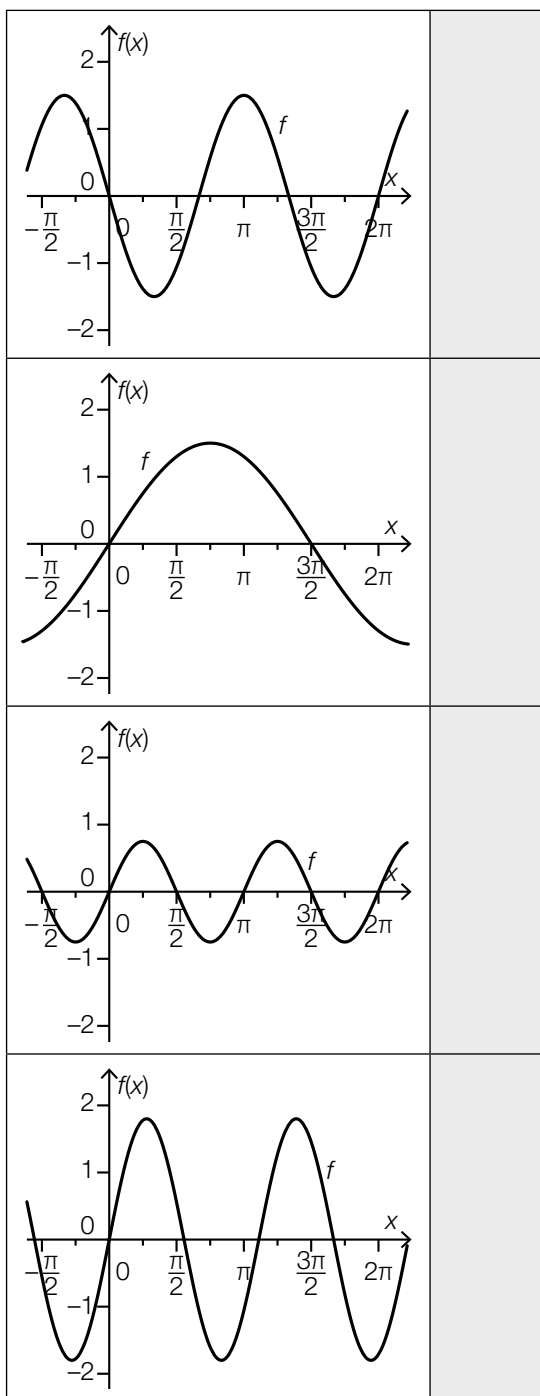

A	$a < 0$ and $b < 1$
B	$a < 0$ and $b > 1$
C	$0 < a < 1$ and $b < 1$
D	$0 < a < 1$ and $b > 1$
E	$a > 1$ and $b < 1$
F	$a > 1$ and $b > 1$

Task 13

Relay Marathon

Every year teams of four people participate in the relay marathon in Linz. Four consecutive sections comprise the marathon (in total around 42.2 km).

A particular team is made up of the people *A*, *B*, *C* and *D*. The table below shows the running times they achieved in the years 2017 and 2018 for each of the sections.

	1 st section	2 nd section	3 rd section	4 th section
year	person <i>A</i>	person <i>B</i>	person <i>C</i>	person <i>D</i>
2017	43 min	1 h 4 min	41 min	1 h 8 min
2018	41 min	58 min	42 min	1 h 2 min

Task:

Write down the person who has seen the greatest percentage change in their running time and calculate this percentage change.

person: _____

percentage change: _____ %

[0/½/1 p.]

Task 14

Graph and Secant Line

The diagram below shows the graph of the differentiable function f as well as the secant line through the points $(a, f(a))$ and $(b, f(b))$.

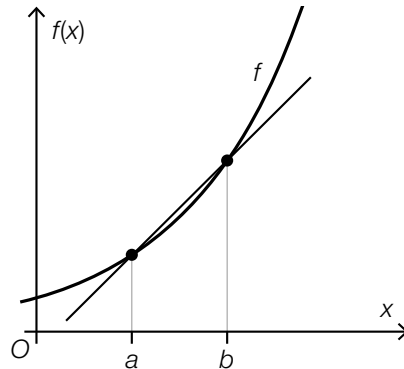

Task:

Complete the gaps in the following sentence by putting a cross next to one of the given possibilities for each gap so that the sentence becomes a correct statement.

The expression $\lim_{a \rightarrow b} \frac{f(b) - f(a)}{b - a}$ is _____ ① _____ and corresponds to the _____ ② _____.

①	
the difference quotient in the interval $[a, b]$	<input type="checkbox"/>
the differential quotient at the point where $x = b$	<input type="checkbox"/>
the average rate of change in the interval $[a, b]$	<input type="checkbox"/>

②	
gradient of the secant line in the interval $[a, b]$	<input type="checkbox"/>
gradient of the tangent at $(a, f(a))$	<input type="checkbox"/>
gradient of the tangent at $(b, f(b))$	<input type="checkbox"/>

[0/1 p.]

Task 15

Air Pressure

Air pressure decreases as the height above sea level becomes greater.

The function $p: \mathbb{R}_0^+ \rightarrow \mathbb{R}^+$ models the air pressure p in terms of the height above sea level h (h in m, $p(h)$ in hectopascals (hPa)).

It is known that $h_1 = 300$ m and $h_2 = 500$ m.

Task:

Interpret the expression $\frac{p(h_2) - p(h_1)}{h_2 - h_1}$ in the given context and write down the corresponding unit.

[0/1 p.]

Task 16

Graph of a Derivative

The graph of the derivative f' of a polynomial function f is shown below. The derivative f' is a 3rd degree polynomial function and has 3 integer zeros.

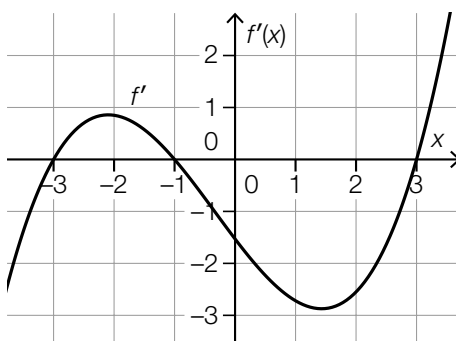

Task:

Put a cross next to each of the two statements that are definitely true about the polynomial function f . [2 out of 5]

f is strictly monotonically increasing in the interval $[2, 3]$.	<input type="checkbox"/>
f is concave up in the interval $[2, 3]$.	<input type="checkbox"/>
The statement $f(-3) \leq f(3)$ holds.	<input type="checkbox"/>
f has exactly 2 points of inflexion.	<input type="checkbox"/>
f has exactly 2 local maxima.	<input type="checkbox"/>

[0/1 p.]

Task 17

Third Degree Polynomial Function

Let f be a 3rd degree polynomial function with $f(x) = a \cdot x^3 + b \cdot x^2 + c \cdot x + d$ with $a, b, c, d \in \mathbb{R}$, $a \neq 0$ and $d \neq 0$.

Task:

Complete the gaps in the following sentence by putting a cross next to one of the given possibilities for each gap so that the sentence becomes a correct statement.

For $b = 0$ and $c \neq 0$ the point where $x = 0$ is definitely a ① and for $c = 0$ and $b \neq 0$ it is definitely a ② .

①	
zero	<input type="checkbox"/>
maximum or minimum	<input type="checkbox"/>
point of inflexion	<input type="checkbox"/>

②	
zero	<input type="checkbox"/>
maximum or minimum	<input type="checkbox"/>
point of inflexion	<input type="checkbox"/>

[0/1/2/1 p.]

Task 18

Marginal Costs and Total Costs

The marginal costs for the production of a particular product are modelled by the function K' . The following statements hold:

$$K'(x) = \frac{1}{100} \cdot \left(x^3 - \frac{x^2}{2} + 3 \cdot x + 4 \right)$$

x ... amount produced in units

$K'(x)$... marginal costs for the amount produced x in euros per unit

The total costs are given in euros.

Task:

Determine the amount by which the total costs rise if 110 units are produced instead of 100 units.

[0/1 p.]

Task 19

Stem-and-Leaf Diagram

Data are displayed below in a stem-and-leaf diagram.

1	2 2 5 5 6
2	2 3 7 7
3	1 1 1 2 2 2 2
4	1 2 7 7 9 9

Task:

Match each of the four values listed below to the corresponding statistical parameter from A to F.

31	
32	
37	
49	

A	median
B	mode
C	mean
D	range
E	standard deviation
F	maximum

[0/1½/1 p.]

Task 20

Sign of Statistical Parameters

The list of data with values $x_1 < \dots < x_n$ with $x_1 < 0$ and $x_n > 0$ is given.

Task:

Put a cross next to the two statistical parameters that are definitely positive for the list of data given above. [2 out of 5]

range	<input type="checkbox"/>
mean	<input type="checkbox"/>
standard deviation	<input type="checkbox"/>
minimum	<input type="checkbox"/>
median	<input type="checkbox"/>

[0/1 p.]

Task 21

Heads or Tails

A coin has a heads side H and a tails side T .

This coin is tossed 3 times. An example of a possible result of this random experiment is THH .

In this string of letters, the 1st letter gives the result of the 1st toss, the 2nd letter the result of the 2nd toss, and the 3rd letter the result of the 3rd toss.

The event that the 2nd toss results in T is given by E .

Task:

Write down the event E as a subset of the corresponding sample space of this random experiment.

$E = \{ \underline{\hspace{15em}} \}$

[0/1 p.]

Task 22

Balls

There are 5 red and n green balls in a container ($n \geq 2$).

3 balls are removed from the container without replacement.

The probability that exactly 2 green balls are removed is given by p .

Task:

Put a cross next to the correct statement. [1 out of 6]

$p = \frac{n}{n+5} \cdot \frac{n-1}{n+5} \cdot \frac{5}{n+5} \cdot 3$	<input type="checkbox"/>
$p = \left(\frac{n}{n+5}\right)^2 \cdot \frac{5}{n+5}$	<input type="checkbox"/>
$p = \frac{n}{n+5} \cdot \frac{n-1}{n+4} \cdot \frac{5}{n+3} \cdot 3$	<input type="checkbox"/>
$p = \frac{5}{n+5} \cdot \left(\frac{n}{n+5}\right)^2 \cdot 3$	<input type="checkbox"/>
$p = \frac{5}{n+5} \cdot \frac{n}{n+4} \cdot \frac{n-1}{n+3}$	<input type="checkbox"/>
$p = \frac{5}{n+5} \cdot \frac{n}{n+5} \cdot \frac{n-1}{n+5}$	<input type="checkbox"/>

[0/1 p.]

Task 23

Penalties

Johanna regularly shoots penalties with her football team.

She has 5 attempts. The random variable X gives the number of goals k scored.

The table below shows the probability distribution of X based on empirical values.

k	0	1	2	3	4	5
$P(X = k)$	0.001	0.008	0.131	0.310	0.372	$P(X = 5)$

Task:

Determine the probability that Johanna scores more than 3 goals in 5 attempts.

$$P(X > 3) = \underline{\hspace{10cm}}$$

[0/1 p.]

Task 24

Therapy

The application of a particular therapy is successful in 90 % of people.

A specialist doctor applies this therapy to 30 people.

The random variable X is assumed to be binomially distributed and gives the number of people for whom the therapy is successful.

Task:

Determine the probability that the number of people for whom the therapy is successful is greater than the expected value $E(X)$.

[0/1 p.]

Task 1

Values of Expressions

Five expressions with $a \in \mathbb{R}$ and $a < 0$ are shown below.

Task:

Put a cross next to both expressions that always have a positive value. [2 out of 5]

$\frac{a-1}{a}$	<input type="checkbox"/>
$\frac{1-2 \cdot a}{a}$	<input type="checkbox"/>
$\frac{a}{1-a}$	<input type="checkbox"/>
$a^2 - 1$	<input type="checkbox"/>
$-a$	<input type="checkbox"/>

[0/1 p.]

Task 2

Quadratic Equation

A quadratic equation in the variable x is shown below.

$$3 \cdot x^2 + a = 2 \cdot x^2 + 6 \cdot x - 4 \quad \text{with } a \in \mathbb{R}$$

Task:

Determine all values of a for which the equation shown above has two distinct solutions in \mathbb{R} .

[0/1 p.]

Task 3

Point on a Line

Let g be a line in \mathbb{R}^3 with $g: X = \begin{pmatrix} 1 \\ 2 \\ -5 \end{pmatrix} + s \cdot \begin{pmatrix} -3 \\ 7 \\ 2 \end{pmatrix}$, $s \in \mathbb{R}$,

and A be a point with $A = \begin{pmatrix} 10 \\ -19 \\ a \end{pmatrix}$, $a \in \mathbb{R}$.

The point A lies on the line g .

Task:

Determine a .

$a =$ _____

[0/1 p.]

Task 4

Perpendicular Vectors

Let $\vec{v} = \begin{pmatrix} 7 \\ -3 \cdot a \end{pmatrix}$ with $a > 1$ be a vector.

Task:

Put a cross next to both vectors that are perpendicular to \vec{v} . [2 out of 5]

$\begin{pmatrix} -3 \cdot a \\ 7 \end{pmatrix}$	<input type="checkbox"/>
$\begin{pmatrix} 1.5 \cdot a \\ 3.5 \end{pmatrix}$	<input type="checkbox"/>
$\begin{pmatrix} -6 \cdot a^2 \\ -14 \cdot a \end{pmatrix}$	<input type="checkbox"/>
$\begin{pmatrix} 1.5 \\ 3.5 \cdot a \end{pmatrix}$	<input type="checkbox"/>
$\begin{pmatrix} 9 \cdot a^2 \\ -21 \cdot a \end{pmatrix}$	<input type="checkbox"/>

[0/1 p.]

Task 5

Calculations for a Triangle

The diagram below shows a triangle that has been divided into two right-angled triangles by the altitude h .

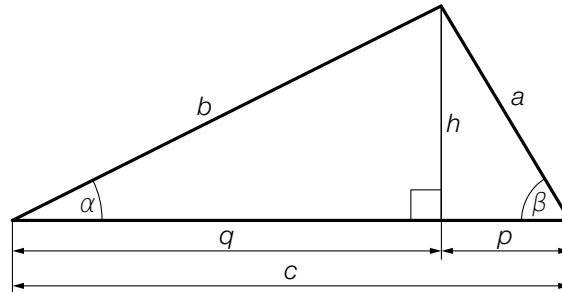

Task:

Match each of the four lengths to the corresponding expression that could be used to calculate that length from A to F.

a	
b	
c	
h	

A	$b \cdot \cos(\alpha)$
B	$\frac{p}{\cos(\beta)}$
C	$\frac{h}{\tan(\beta)}$
D	$q \cdot \tan(\alpha)$
E	$q + \frac{h}{\tan(\beta)}$
F	$\frac{q}{\cos(\alpha)}$

[0/1/2/1 p.]

Task 6

Intervals

Six different intervals are shown below.

For all angles α in one of these intervals, the following statements hold: $\sin(\alpha) \geq 0$ and $\sin(\alpha) \neq 1$.

Task:

Put a cross next to the correct interval. [1 out of 6]

$[270^\circ, 360^\circ)$	<input type="checkbox"/>
$[90^\circ, 180^\circ]$	<input type="checkbox"/>
$(0^\circ, 180^\circ)$	<input type="checkbox"/>
$[0^\circ, 90^\circ)$	<input type="checkbox"/>
$(90^\circ, 270^\circ]$	<input type="checkbox"/>
$[180^\circ, 270^\circ]$	<input type="checkbox"/>

[0/1 p.]

Task 7

Properties of Real Functions

Properties of a real function f are shown below.

Task:

Match each of the four properties to the corresponding statement from A to F.

For all $x \in \mathbb{R}$, $f(x) = f(-x)$.	
For a particular $m \in \mathbb{R}^+$, $f(x + m) = f(x)$ for all $x \in \mathbb{R}$.	
For all $x_1, x_2 \in \mathbb{R}$ with $x_1 < x_2$, $f(x_1) > f(x_2)$.	
For all $x \in \mathbb{R}$, $f(x) \neq 0$.	

A	f is strictly monotonically increasing.
B	The graph of f is symmetrical about the vertical axis.
C	The graph of f has an asymptote.
D	f is strictly monotonically decreasing.
E	f is periodic.
F	The graph of f has no point of intersection with the x -axis.

[0/1/2/1 p.]

Task 8

Linear Function

Let $f: \mathbb{R} \rightarrow \mathbb{R}$ be a linear function with $f(x) = m \cdot x + c$ and $m, c \in \mathbb{R}$.

Task:

Complete the gaps in the following sentence by putting a cross next to one of the given possibilities for each gap so that the sentence becomes a correct statement.

For all $x \in \mathbb{R}$, the following statement holds: _____ ^① = _____ ^② .

①	
$f(x + 1)$	<input type="checkbox"/>
$f(x + 2)$	<input type="checkbox"/>
$f(x + 1) + f(x + 1)$	<input type="checkbox"/>

②	
$f(x) + 2 \cdot m$	<input type="checkbox"/>
$f(x) + c$	<input type="checkbox"/>
$2 \cdot f(x) + 2$	<input type="checkbox"/>

[0/1 p.]

Task 9

Indirect Proportion

Six mappings with $x \in \mathbb{R}^+$ are shown below.

Task:

Put a cross next to the mapping that describes an indirectly proportional relationship. [1 out of 6]

$x \mapsto 3 - x$	<input type="checkbox"/>
$x \mapsto -\frac{x}{3}$	<input type="checkbox"/>
$x \mapsto \frac{3}{x^2}$	<input type="checkbox"/>
$x \mapsto 3 \cdot x^{-1}$	<input type="checkbox"/>
$x \mapsto 3^{-x}$	<input type="checkbox"/>
$x \mapsto x^{-3}$	<input type="checkbox"/>

[0/1 p.]

Task 10

Odd Function

For the function $f: \mathbb{R} \rightarrow \mathbb{R}$ with $f(x) = a \cdot x^n$ ($a \in \mathbb{R}, a \neq 0$) with an odd $n \in \mathbb{N}$, the table of values shown below is given.

x	-2	0	2
$f(x)$	v	0	w

In this table, $v, w \in \mathbb{R}$.

Task:

Write down the relationship between v and w as an equation.

[0/1 p.]

Task 11

Half-Life

The half-life of a particular radioactive substance is T years.

The amount of the radioactive substance that is still present after t years is given by $m(t)$ for which $m(0) > 0$.

Task:

Put a cross next to both correct equations. [2 out of 5]

$m(T) = \frac{1}{2} \cdot m(0)$	<input type="checkbox"/>
$m(2 \cdot T) = 0$	<input type="checkbox"/>
$m(3 \cdot T) = \frac{7}{8} \cdot m(0)$	<input type="checkbox"/>
$m(4 \cdot T) = \frac{1}{4} \cdot m(T)$	<input type="checkbox"/>
$m(5 \cdot T) = \frac{1}{2} \cdot m(4 \cdot T)$	<input type="checkbox"/>

[0/1 p.]

Task 12

Sounds

The functions f , g and h each describe vibrations that create sounds in terms of the time t (in seconds).

For these functions:

$$f(t) = \sin(600 \cdot t)$$

$$g(t) = \frac{5}{4} \cdot \sin(800 \cdot t)$$

$$h(t) = \frac{6}{5} \cdot \sin(500 \cdot t)$$

The volume of a sound is higher the greater the amplitude (maximum displacement) of the corresponding vibration.

The pitch of a sound is higher the greater the frequency (number of vibrations per second) of the corresponding vibration.

Task:

Complete the gaps in the following sentence by putting a cross next to one of the given possibilities for each gap so that the sentence becomes a correct statement.

The vibration of the sound with the highest volume is given by the function _____^①_____;
the vibration of the sound with the lowest pitch is given by the function _____^②_____.

①	
f	<input type="checkbox"/>
g	<input type="checkbox"/>
h	<input type="checkbox"/>

②	
f	<input type="checkbox"/>
g	<input type="checkbox"/>
h	<input type="checkbox"/>

[0/1½/1 p.]

Task 13

Body Weight of a Baby

The body weights of babies in the first 6 weeks of life can be approximated by the function $G: [0, 6] \rightarrow \mathbb{R}$ with $G(t) = G_0 + 190 \cdot t$.

t ... time after the birth in weeks

$G(t)$... body weight of a baby at time t in g

G_0 ... body weight of a baby at birth in g

Nora weighed 3200 g when she was born.

Task:

Using the function G , determine the relative change in Nora's weight from her birth until 6 weeks after birth as a percentage.

_____ %

[0/1 p.]

Task 14

Average Speed

The graph of the distance-time function s of a moving body is shown below. The time t is given in seconds and the distance $s(t)$ is given in metres.

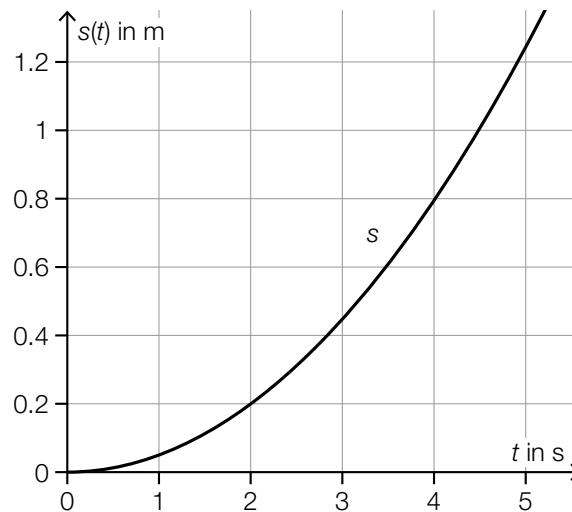

Task:

Determine the time t_1 such that the average speed of the body in the intervals $[0, 4]$ and $[1, t_1]$ is the same.

$t_1 =$ _____ seconds

[0/1 p.]

Task 15

Differentiation Rules

Let f and g be two differentiable functions and a be a positive real number.

Task:

Put a cross next to both functions that definitely correspond to $(a^2 \cdot (f + g))'$. [2 out of 5]

$2 \cdot a \cdot f' + 2 \cdot a \cdot g'$	<input type="checkbox"/>
$a^2 \cdot f' + a^2 \cdot g'$	<input type="checkbox"/>
$2 \cdot a \cdot (f + g)'$	<input type="checkbox"/>
$a^2 \cdot (f + g)'$	<input type="checkbox"/>
$f' + g'$	<input type="checkbox"/>

[0/1 p.]

Task 16

Antiderivative

The diagram below shows the graph of the real function $f: [0, 8] \rightarrow \mathbb{R}$, $x \mapsto f(x)$. The function F with $F(0) = 0$ is an antiderivative of f . The points shown in bold have integer coordinates.

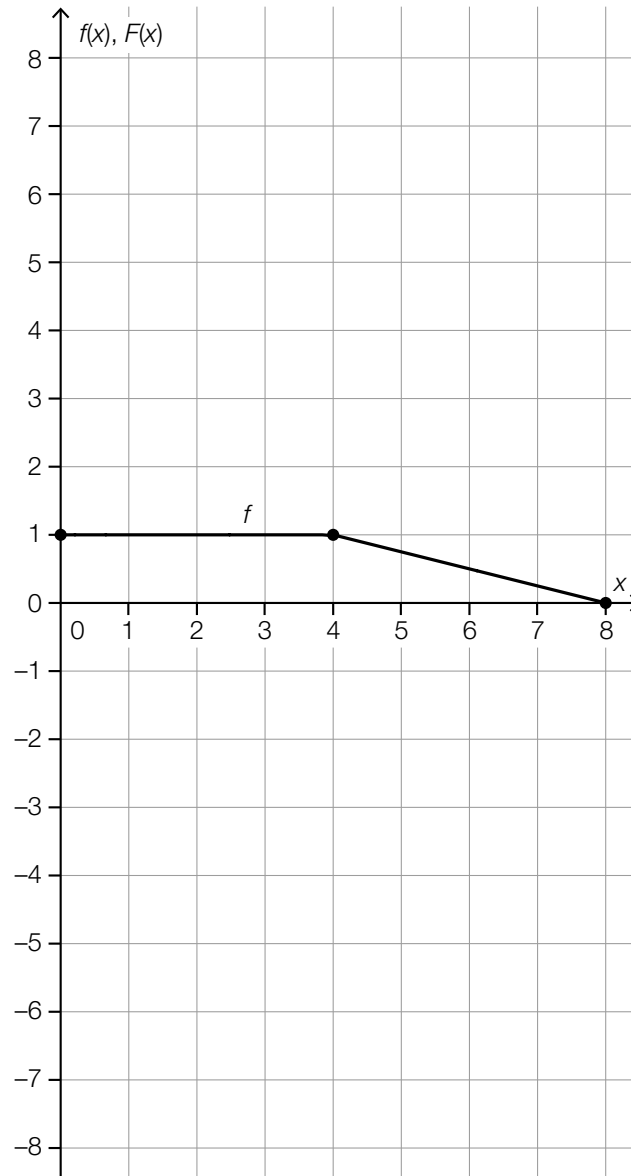

Task:

On the diagram above, sketch the graph of F in the interval $[0, 8]$ using the values of the function $F(0)$, $F(4)$ and $F(8)$.

[0/1½/1 p.]

Task 17

Third Degree Polynomial Function

The minimum $T = (-1, 2)$ and the maximum $H = (1, 4)$ of the graph of a third degree polynomial function f are known.

Task:

Put a cross next to both true statements. [2 out of 5]

The function f is strictly monotonically decreasing in the interval $(1, 3)$.	<input type="checkbox"/>
The function f changes monotonicity in the interval $(-1, 1)$.	<input type="checkbox"/>
The function f is strictly monotonically decreasing in the interval $(-3, 1)$.	<input type="checkbox"/>
The function f is always concave down in the interval $(-1, 1)$.	<input type="checkbox"/>
The function f changes monotonicity in the interval $(0, 2)$.	<input type="checkbox"/>

[0/1 p.]

Task 18

Garden Pond

The function f models the instantaneous rate of change of the water level of a particular garden pond in terms of the time t .

t ... time in days

$f(t)$... instantaneous rate of change of the water level at time t in mm/day

The function F is an antiderivative of f .

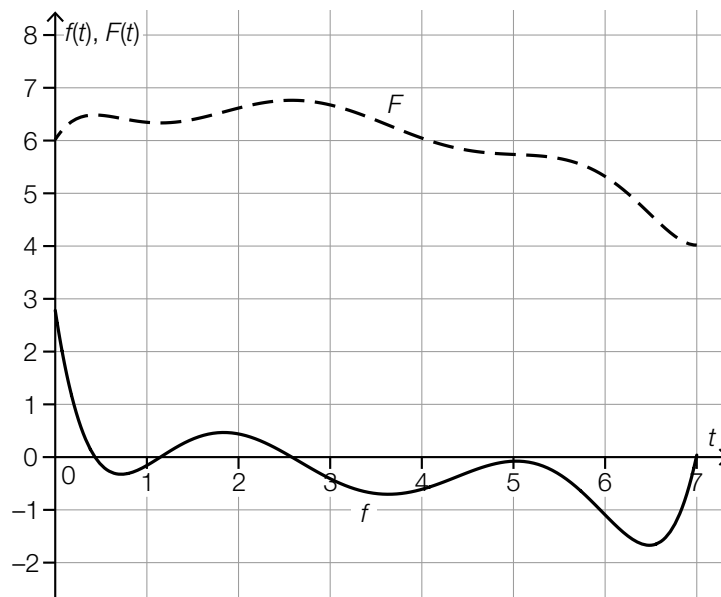

Task:

Complete the gaps in the following sentence by putting a cross next to one of the given possibilities for each gap so that the sentence becomes a correct statement.

The integral $\int_0^7 f(t) dt$ has the value ① , and gives the ② of the water level in the time interval $[0, 7]$.

①	
2	<input type="checkbox"/>
-2	<input type="checkbox"/>
0	<input type="checkbox"/>

②	
average rate of change	<input type="checkbox"/>
relative change	<input type="checkbox"/>
absolute change	<input type="checkbox"/>

[0/½/1 p.]

Task 19

Wealth Distribution

The diagram below shows the relative proportion of the Austrian net wealth held by the richest members of the population in the year 2017.

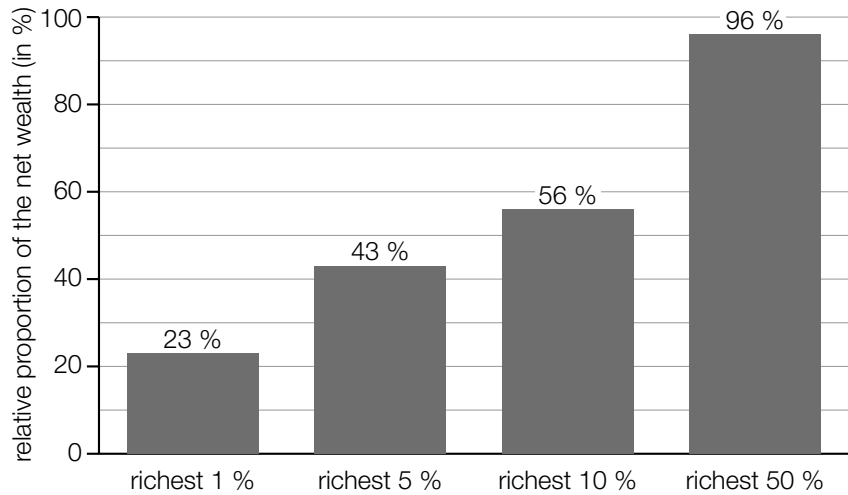

Data sources: <https://awblog.at/vermoegensverteilung-oesterreich/> [04/05/2020],
<https://www.vienna.at/vermoegensverteilung-in-oesterreich-arm-und-reich-wird-meist-ererbt/6468838> [30/05/2020].

Task:

Complete the gaps in the following sentence by putting a cross next to one of the given possibilities for each gap so that the sentence becomes a correct statement.

In the year 2017, the ① of the population held in total ② of the Austrian net wealth.

①	
poorest 50 %	<input type="checkbox"/>
richest 6 %	<input type="checkbox"/>
poorest 95 %	<input type="checkbox"/>

②	
43 %	<input type="checkbox"/>
more than 60 %	<input type="checkbox"/>
4 %	<input type="checkbox"/>

[0/1 p.]

Task 20

Average Income

Of all the employees of a particular company, 40 % work in sales and 52 % in production. The remaining employees work in administration.

The table below shows information about the average net annual incomes in the year 2018.

	average net annual income in the year 2018 per person (in euros)
sales	26376
production	28511
administration	23427

Task:

For this company, determine the average net annual income per person in the year 2018.

[0/1 p.]

Task 21

Newborns

The table below shows the number of newborns in Austria with respect to their birth weights (weight immediately after birth) for the year 2018.

birth weight	number of newborns
less than 2 500 g	5 282
at least 2 500 g and less than 3 500 g	47 152
at least 3 500 g	32 370

Data source: https://www.statistik.at/wcm/idc/idcplg?IdcService=GET_PDF_FILE&RevisionSelectionMethod=LatestReleased&dDocName=110630 [10/04/2020].

If a newborn weighs less than 2 500 g, they are classified as “underweight”.

Task:

For the year 2018, determine the relative proportion of newborns in Austria who were classified as “underweight”.

[0/1 p.]

Task 22

Sports Competition

20 people participated in a sports competition. These people were divided into groups.

Task:

Interpret $\binom{20}{4} = 4845$ in the given context.

[0/1 p.]

Task 23

Probability Distribution of a Random Variable

Let X be a random variable that can only take the values 1, 2, 3, or 4.

It is known that $P(X = 2)$ is twice as large as $P(X = 1)$.

Task:

In the diagram below, draw the missing values $P(X = 2)$ and $P(X = 3)$ in the probability distribution of X .

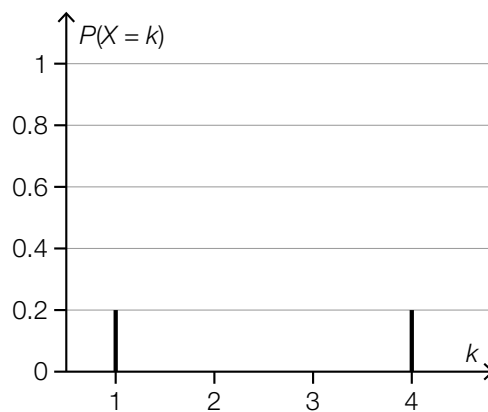

[0/1 p.]

Task 24

Binomially Distributed Random Variable

A particular random experiment either results in “success” or “failure”. This random experiment is conducted 30 times. The binomially distributed random variable X gives the number of times “success” occurs. The expectation value is $E(X) = 12$.

Task:

Determine the probability $P(18 \leq X \leq 20)$.

$P(18 \leq X \leq 20) =$ _____

[0/1 p.]

Task 1

Sets of Numbers

Statements about sets of numbers are shown below.

Task:

Put a cross next to each of the two correct statements. *[2 out of 5]*

The set of integers is a subset of the set of natural numbers.	<input type="checkbox"/>
The set of rational numbers contains all integers.	<input type="checkbox"/>
The set of rational numbers contains all real numbers.	<input type="checkbox"/>
The set of complex numbers is a subset of the set of real numbers.	<input type="checkbox"/>
All irrational numbers are contained within the set of real numbers.	<input type="checkbox"/>

[0/1 p.]

Task 2

Museum Visits

The entrance fees for a particular museum are determined as follows:

The entrance fee for an adult is x euros. For students, this entrance fee is reduced by p %.

Children and youths pay nothing to enter.

On a particular weekend, E people pay the entrance fee for adults and S people pay the entrance fee for students. In addition, K children and J youths visit the museum on this weekend.

The total income of the museum from entrance fees on this weekend is given by G .

Task:

Write down a formula that can be used to calculate G .

$G =$ _____

[0/1 p.]

Task 3

Changing Schools

At a particular academic secondary school (AHS), k pupils decide to attend the upper secondary school at this school at the end of the 8th class. All of the remaining m pupils decide to change to a college for higher vocational education (BHS).

The following statements hold:

- A third of the pupils of this 8th class change to a BHS.
- The number of pupils who will attend the upper secondary school at this school is 47 greater than the number of pupils who will change to a BHS.

Task:

Put a cross next to each of the two correct equations. [2 out of 5]

$k + m = 3 \cdot m$	<input type="checkbox"/>
$k = 2 \cdot m - 47$	<input type="checkbox"/>
$m = k - 47$	<input type="checkbox"/>
$k = 3 \cdot m$	<input type="checkbox"/>
$3 \cdot k - m = 47$	<input type="checkbox"/>

[0/1 p.]

Task 4

Points and Vectors

Three points A , B and C as well as three vectors \vec{r} , \vec{v} and \vec{w} are shown in the coordinate system below.

The points have integer coordinates, and the vectors have integer components.

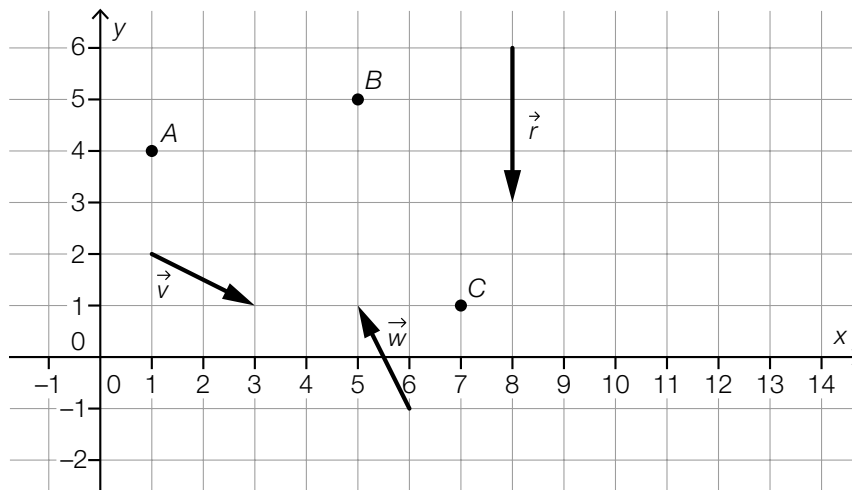

Task:

Put a cross next to each of the two correct statements. [2 out of 5]

$A = B + t \cdot \vec{r}$ for a $t \in \mathbb{R}$	<input type="checkbox"/>
$B = C + t \cdot \vec{v}$ for a $t \in \mathbb{R}$	<input type="checkbox"/>
$C = B + t \cdot \vec{w}$ for a $t \in \mathbb{R}$	<input type="checkbox"/>
$B = A + t \cdot \vec{w}$ for a $t \in \mathbb{R}$	<input type="checkbox"/>
$C = A + t \cdot \vec{v}$ for a $t \in \mathbb{R}$	<input type="checkbox"/>

[0/1 p.]

Task 5

Vectors in a Rectangle

A rectangle with vertices A , B , C and D is shown below. The point of intersection of the two diagonals is given by M .

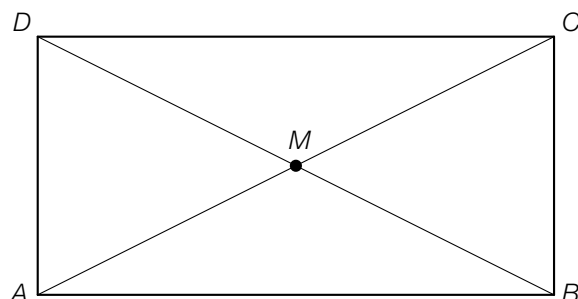

Task:

Put a cross next to each of the two correct statements. [2 out of 5]

$\vec{AD} = \frac{1}{2} \cdot \vec{AC} + \frac{1}{2} \cdot \vec{BD}$	<input type="checkbox"/>
$\vec{MA} = \frac{1}{2} \cdot \vec{CM}$	<input type="checkbox"/>
$\frac{3}{5} \cdot \vec{CD} = -\frac{2}{5} \cdot \vec{AB}$	<input type="checkbox"/>
$\vec{DC} = \vec{BD} - \vec{AD}$	<input type="checkbox"/>
$\frac{1}{2} \cdot \vec{AD} = -\frac{1}{2} \cdot \vec{CB}$	<input type="checkbox"/>

[0/1 p.]

Task 6

Perpendicular Lines

The vector equation of the line g is given by:

$$g: X = \begin{pmatrix} -2 \\ 0 \\ 7 \end{pmatrix} + s \cdot \begin{pmatrix} 4 \\ -4 \\ 2 \end{pmatrix} \text{ with } s \in \mathbb{R}$$

For a line n , the following statements hold:

- n is perpendicular to g .
- n intersects with g at the point $P = (2, -4, 9)$.

Task:

Write down a vector equation of one such line n .

$$n: X = \underline{\hspace{15cm}}$$

[0/1 p.]

Task 7

Centripetal Force

When a body moves along a circular path of radius r at constant velocity v , the absolute value of the centripetal force F is a function of the mass m of this body.

The following equation holds: $F(m) = \frac{m \cdot v^2}{r}$

Task:

On the diagram below, sketch the graph of F so that it goes through the point A.

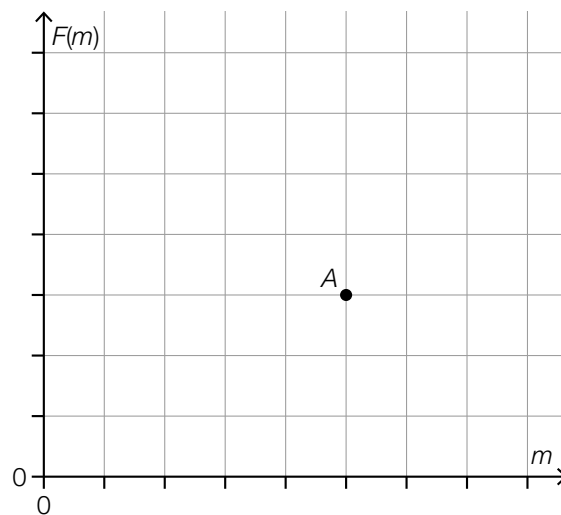

[0/1 p.]

Task 8

Graphs of Functions

Four types of functions as well as characteristic sections of six graphs of functions are shown below.

Task:

Match each of the four types of functions to its corresponding graph from A to F.

exponential function	
linear function	
2 nd degree polynomial function	
sine function	

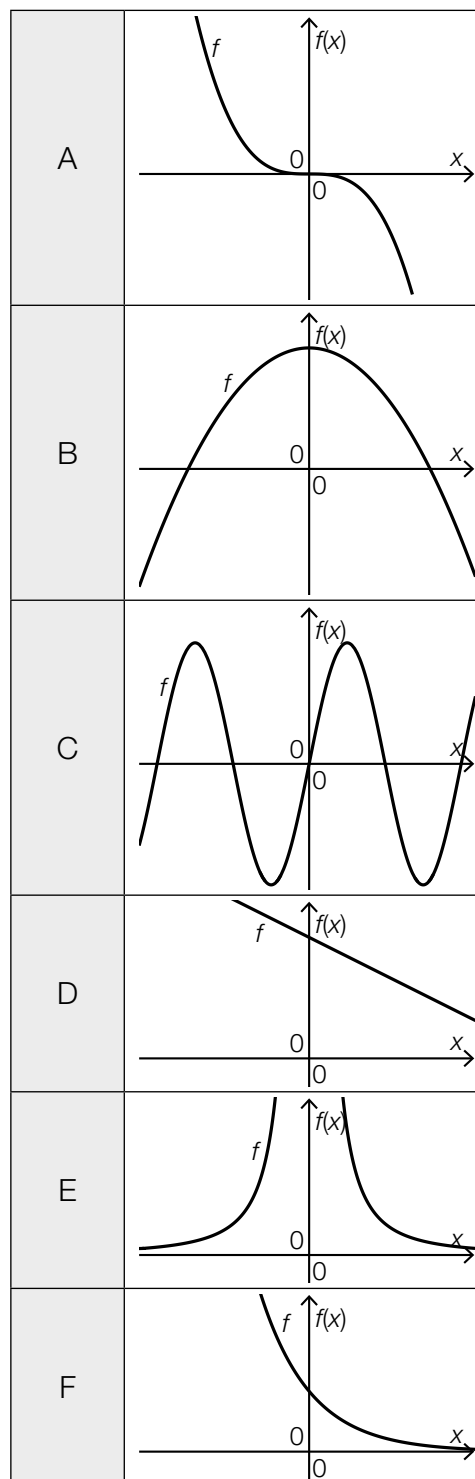

Task 9

Revenue and Profit

The diagram below shows the graph of the linear revenue function $E: x \mapsto E(x)$ and the graph of the linear profit function $G: x \mapsto G(x)$ (x in kg, $E(x)$ and $G(x)$ in €).

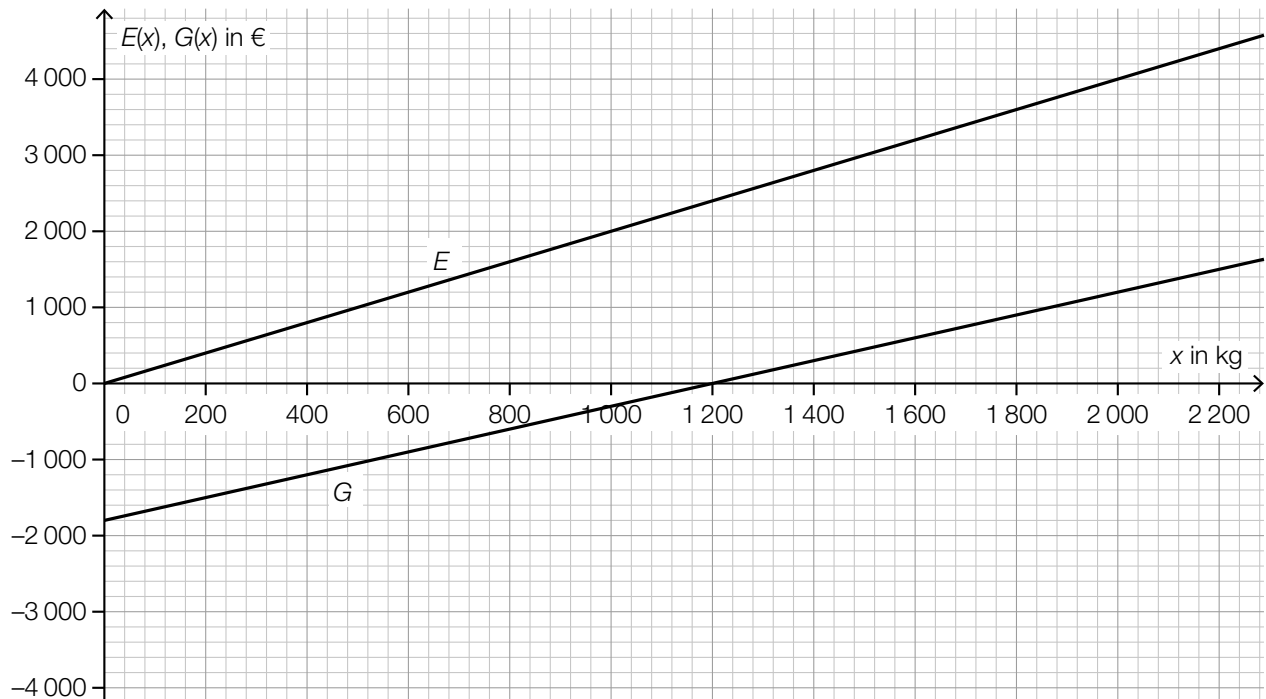

Task:

Write down the sales price and the fixed costs.

sales price: _____ €/kg

fixed costs: € _____

[0/½/1 p.]

Task 10

Filling Machines

If four equally fast filling machines are used simultaneously, they require 24 minutes to fill 6000 bottles of mineral water.

The function f assigns a number n of such simultaneously working filling machines to the time $f(n)$ required to fill 6000 bottles ($n \in \mathbb{N} \setminus \{0\}$ and $f(n)$ in minutes).

Task:

Write down an equation of the function f .

$f(n) =$ _____

[0/1 p.]

Task 11

Flu Infections

On the evening of the 10th February 2019, 2 000 people were infected with flu in a particular country; on the evening of the 21st February 2019, 4 000 people were infected. It can be assumed that the number of people infected with flu rose by the same percentage each day in this country in February 2019.

Task:

Determine this percentage.

[0/1 p.]

Task 12

Properties of a Sine Function

Let $f: \mathbb{R} \rightarrow \mathbb{R}$ be a function with $f(x) = a \cdot \sin(b \cdot x)$ with $a, b \in \mathbb{R}^+$.

Task:

Put a cross next to each of the two statements that are true about the function f . [2 out of 5]

The greater the value of b , the greater the length of the (shortest) period is.	<input type="checkbox"/>
The smaller the value of a , the greater the length of the (shortest) period is.	<input type="checkbox"/>
The smaller the value of a , the smaller the number of zeros in the interval $[0, 2 \cdot \pi]$ is.	<input type="checkbox"/>
The greater the value of a , the greater the difference between the greatest and lowest value of the function is.	<input type="checkbox"/>
The greater the value of b , the smaller the distance between two consecutive zeros is.	<input type="checkbox"/>

[0/1 p.]

Task 13

Relative Change of a Polynomial Function

The graph of the polynomial function f is shown below.

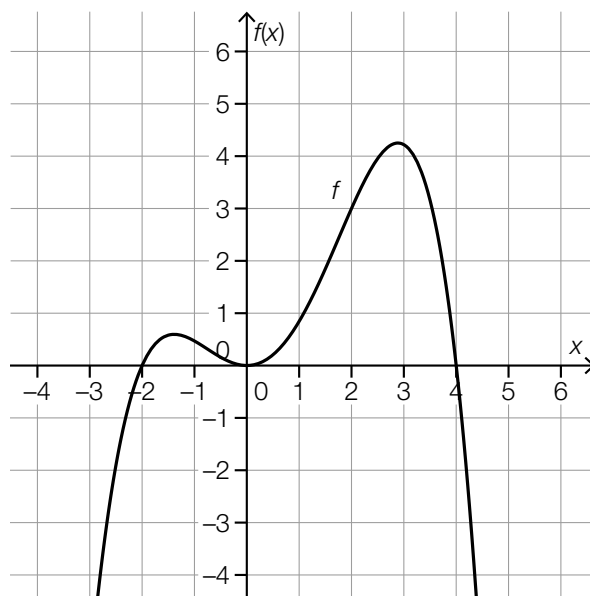

Task:

Determine the relative change of f in the interval $[2, 4]$.

[0/1 p.]

Task 14

Decline of a Population

The number $f(t)$ of individuals in a population during an observation period of 100 weeks is modelled by a function f . The time t is given in weeks.

Task:

Put a cross next to the statement that correctly describes the relationship $\frac{f(100) - f(0)}{100} = -35$ in the given context. [1 out of 6]

The number of individuals reduced by 35 per week during the observation period.	<input type="checkbox"/>
At the beginning of the observation period, there were 35 % more individuals than at the end of this time period.	<input type="checkbox"/>
The number of individuals reduced by an average of 35 per week during the observation period.	<input type="checkbox"/>
The number of individuals reduced to 35 % of the original population during the observation period.	<input type="checkbox"/>
The number of individuals reduced by 35 % per week during the observation period.	<input type="checkbox"/>
The number of individuals reduced by a total of 35 during the observation period.	<input type="checkbox"/>

[0/1 p.]

Task 15

First Derivative

Let $f: \mathbb{R} \rightarrow \mathbb{R}$, $x \mapsto f(x)$ be a differentiable function.

The following statement holds: $f'(0) = 2$

Let $g: \mathbb{R} \rightarrow \mathbb{R}$ be a function with $g(x) = a \cdot f(k \cdot x)$ for two numbers $a, k \in \mathbb{R}$.

Task:

Write down a formula that can be used to calculate $g'(0)$ in terms of a and k .

$g'(0) =$ _____

[0/1 p.]

Task 16

Derivative and Antiderivative

The diagram below shows the graph of the 3rd degree polynomial function f . All local maxima and minima and the point of inflexion of f have integer coordinates.

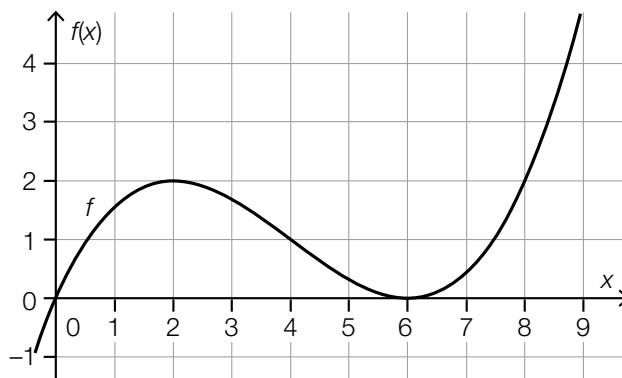

Task:

Complete the gaps in the following sentence by putting a cross next to one of the given possibilities for each gap so that the sentence becomes a correct statement.

The graph of the 1st derivative of f _____ ① _____ and the graphs of all antiderivatives of f _____ ② _____.

①	
crosses the x -axis when $x = 4$	<input type="checkbox"/>
is strictly monotonically decreasing in the interval $(-\infty, 4)$	<input type="checkbox"/>
is concave down in the interval $(-\infty, 4)$	<input type="checkbox"/>

②	
have a point of inflexion with a horizontal tangent when $x = 6$	<input type="checkbox"/>
cross the x -axis when $x = 6$	<input type="checkbox"/>
are strictly monotonically decreasing in the interval $(2, 6)$	<input type="checkbox"/>

[0/1/2/1 p.]

Task 17

Derivative of a Third-Degree Polynomial Function

A 3rd degree polynomial function f has a local maximum at $x_1 = -2$ and a local minimum at $x_2 = 2$.

The function has the 1st derivative f' .

Task:

Put a cross next to each of the two correct statements. [2 out of 5]

f' is positive over the whole interval $(-2, 2)$.	<input type="checkbox"/>
f' has the same value at x_1 as at x_2 .	<input type="checkbox"/>
f' is negative over the whole interval $(-3, -2)$.	<input type="checkbox"/>
f' has a positive value at $x = 4$.	<input type="checkbox"/>
f' has the value 0 at $x = 0$.	<input type="checkbox"/>

[0/1 p.]

Task 18

Fungal Spores

Fungi reproduce using spores.

In an experiment, the spores of a particular fungus cover an area of $5 \mu\text{m}^2$ at time $t = 0$.

The function f models the speed at which the covered area increases in terms of the time t .

t ... time in h

$f(t)$... speed at which the covered area increases at time t in $\mu\text{m}^2/\text{h}$

Task:

Interpret $5 + \int_0^3 f(t) dt$ in the given context.

[0/1 p.]

Task 19

Speed Check

On a section of motorway the speeds of vehicles are measured, and then the histogram shown below is created. The area of a rectangle corresponds to the absolute frequency of the speeds in each class.

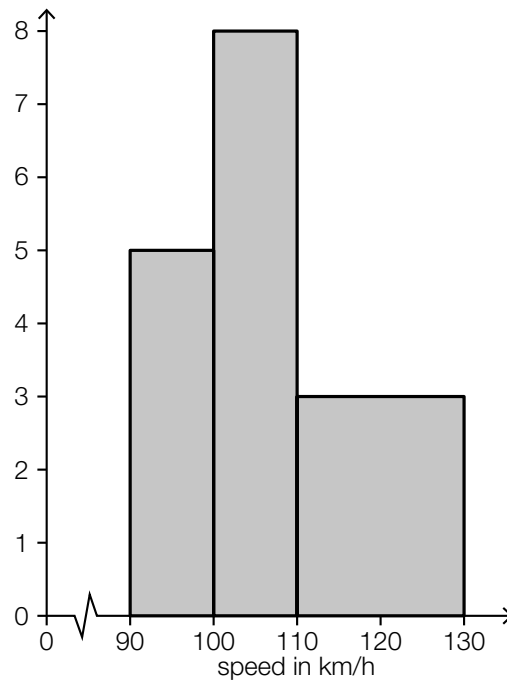

Task:

Determine the number of vehicles that were included in the creation of the histogram.

[0/1 p.]

Task 20

Points on a Test

In the lower secondary school, Sophie took 16 mathematics tests. In each of these mathematics tests, 48 points were available. The mean of the total number of points achieved by Sophie was 38.5 points.

In the first two mathematics tests in the upper secondary school, Sophie scored 41 points and 47 points respectively out of a maximum of 48 available points.

Task:

Determine the mean \bar{x} of the number of points achieved by Sophie across all 18 mathematics tests.

[0/1 p.]

Task 21

Median and Mean

For a particular group of 11 people, the following statements hold: the mean of their gross salaries is € 5,690; the median of their gross salaries is € 3,200.

Task:

Put a cross next to the two statements that are always true. [2 out of 5]

At least 1 person in this group has a gross salary of exactly € 3,200.	<input type="checkbox"/>
At least 1 person in this group has a gross salary of exactly € 5,690.	<input type="checkbox"/>
At least 6 people in this group have a gross salary of at most € 3,200.	<input type="checkbox"/>
At most 1 person in this group has a gross salary of more than € 5,690.	<input type="checkbox"/>
At least 5 people in this group have a gross salary of more than € 5,690.	<input type="checkbox"/>

[0/1 p.]

Task 22

Christmas Presents

According to a survey, 87 % of the Austrian population buy Christmas presents. Out of this section of the population, 3 % are “last-minute shoppers”, who only start buying presents a few days before Christmas.

Data source: <https://ooe.orf.at/stories/3020487/> [07.11.2019].

Task:

Using the data from this survey, determine the proportion p of “last-minute shoppers” of the Austrian population as a percentage.

$p =$ _____ %

[0/1 p.]

Task 23

Binomial Coefficients

Let a and b be two natural numbers with $0 \leq a < b \leq 9$.

For two binomial coefficients, the following statement holds:

$$\binom{9}{a} = \binom{9}{b}$$

Task:

Write down an expression for a in terms of b .

$a =$ _____

[0/1 p.]

Task 24

Expected Values and Standard Deviations

Let X and Y be two random variables, which can each take exactly 7 integer values with a positive probability. The probability distributions for X and Y are shown below.

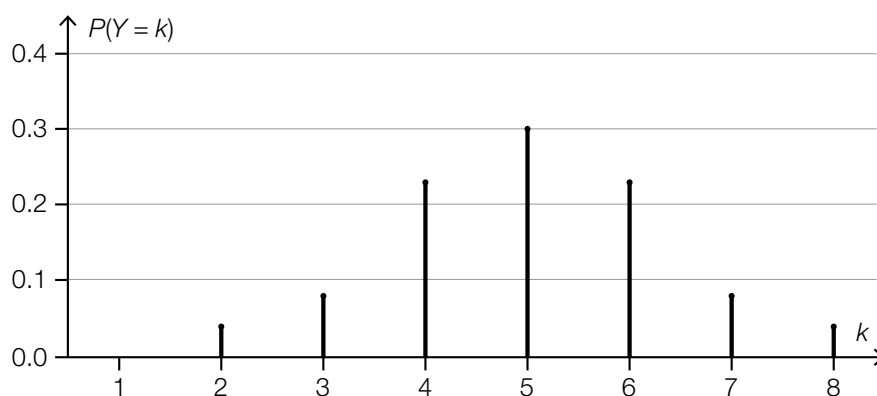
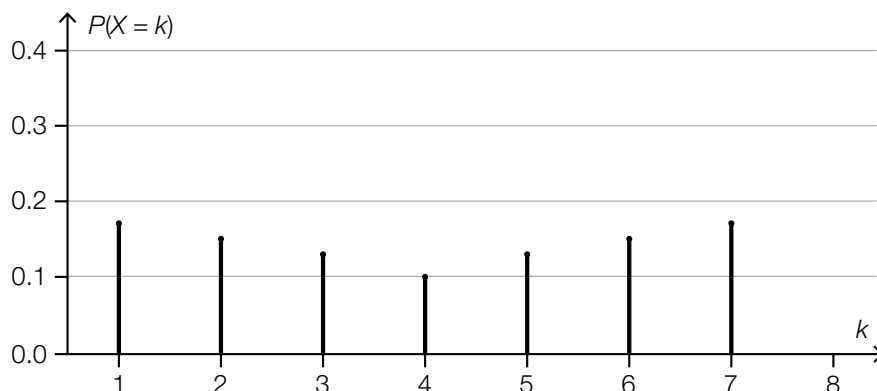

Task:

Complete the gaps in the following sentence by putting a cross next to one of the given possibilities for each gap so that the sentence becomes a correct statement.

For the expected values $E(X)$ and $E(Y)$, the statement _____ ① _____ holds;
 for the standard deviations $\sigma(X)$ and $\sigma(Y)$, the statement _____ ② _____ holds.

①	
$E(X) < E(Y)$	<input type="checkbox"/>
$E(X) = E(Y)$	<input type="checkbox"/>
$E(X) > E(Y)$	<input type="checkbox"/>

②	
$\sigma(X) < \sigma(Y)$	<input type="checkbox"/>
$\sigma(X) = \sigma(Y)$	<input type="checkbox"/>
$\sigma(X) > \sigma(Y)$	<input type="checkbox"/>

Task 1

Sum and Product of Two Numbers

Let a and b be two numbers with $a, b \in \mathbb{R}$ such that $a + b = a \cdot b$

Task:

Justify in general why it is not possible for both a and b to be negative under this condition.

[0/1 p.]

Task 2

Pure Water

Pure water consists solely of water molecules. It can be assumed that one water molecule has a mass of $3 \cdot 10^{-23}$ g.

Task:

Determine the number of water molecules in 3 kg of pure water.

[0/1 p.]

Task 3

Rental Properties

Alexander rents out four apartments.

The table below shows the gross rents and the running costs for a particular year.

	gross rent (in €)	running costs (in €)
apartment 1	4800	1200
apartment 2	5500	1400
apartment 3	6000	1800
apartment 4	7000	1900

The columns of the table can be written as vectors. The vector B gives the gross rents, and the vector K gives the running costs.

The gross rents are the sum of the net rents and the running costs. The profit (after tax) is 60 % of the net rents.

Task:

Determine the vector G , whose components give Alexander's profits from renting the four apartments.

[0/1 p.]

Task 4

Point on the Side of a Rectangle

A rectangle with vertices A , B , C and D is shown below. The point T divides the line segment CD in a ratio of 3 : 1 (see diagram below).

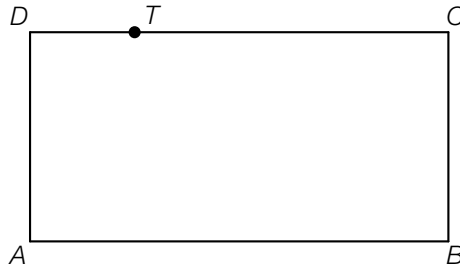

For the point T , the following statement holds:

$$T = A + r \cdot \overrightarrow{AB} + s \cdot \overrightarrow{DA} \text{ with } r, s \in \mathbb{R}$$

Task:

Determine r and s .

$$r = \underline{\hspace{10cm}}$$

$$s = \underline{\hspace{10cm}}$$

[0/1½/1 p.]

Task 5

Two Lines in Three-Dimensional Space

Let g and h be two lines in \mathbb{R}^3 .

- $g: X = A + t \cdot \vec{a}$ with $t \in \mathbb{R}$
- $h: X = B + s \cdot \vec{b}$ with $s \in \mathbb{R}$

Task:

Complete the gaps in the following sentence by putting a cross next to one of the given possibilities for each gap so that the sentence becomes a correct statement.

If _____ ① _____ holds, then the lines g and h must _____ ② _____.

①	
$A \notin h$ and $\vec{a} = \vec{b}$	<input type="checkbox"/>
$B \in g$ and $\vec{a} \cdot \vec{b} = 0$	<input type="checkbox"/>
$\vec{a} = r \cdot \vec{b}$ with $r \in \mathbb{R} \setminus \{0\}$ and $B \notin g$	<input type="checkbox"/>

②	
intersect	<input type="checkbox"/>
be identical	<input type="checkbox"/>
be skew	<input type="checkbox"/>

[0/1 p.]

Task 6

Quadrilateral

The diagram below shows a quadrilateral.

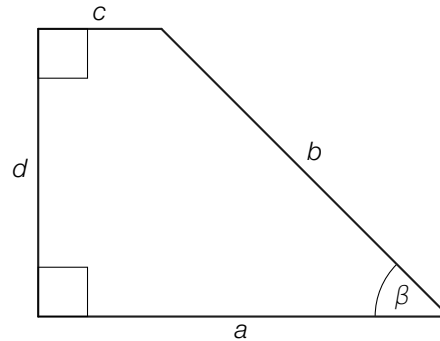

Task:

Using the required side lengths, write down a formula that can be used to calculate $\tan(\beta)$.

$\tan(\beta) =$ _____

[0/1 p.]

Task 7

Containers

Cylindrical containers are produced that all have the same volume V_0 .

The function h describes the height of one such container in terms of the area G of its base (G in cm^2 , $h(G)$ in cm). The graph of the function h is shown in the diagram below.

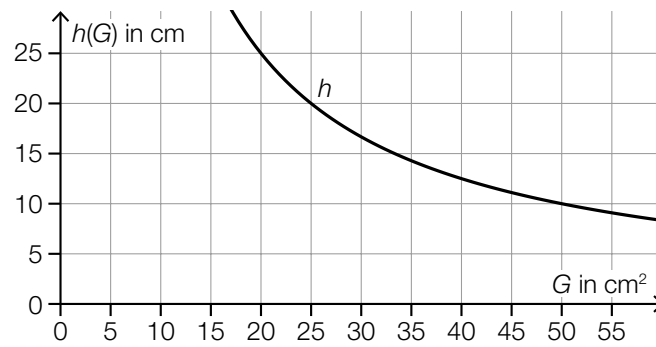

Task:

Determine V_0 .

[0/1 p.]

Task 8

Properties of Functions

Real functions including the parameters $a \in \mathbb{R}^+$ and $b \in (0, 1)$ are shown below.

Task:

Match each of the four equations of functions shown below to the corresponding property from A to F.

$f(x) = a \cdot x + b$	
$f(x) = a \cdot x^2 + b$	
$f(x) = a \cdot b^x$	
$f(x) = a \cdot \sin(b \cdot x)$	

A	$f(x) = f(-x)$ for all $x \in \mathbb{R}$ holds.
B	$f(x) = -f(-x)$ for all $x \in \mathbb{R}$ holds.
C	f is strictly monotonically decreasing in \mathbb{R} .
D	f has exactly two zeros.
E	f is concave down for all $x \in \mathbb{R}$.
F	f has exactly one zero.

[0/½/1 p.]

Task 9

Falling Ball

A ball falls from a viewing platform. The function h models the height of the falling ball above the ground in terms of the time t .

The following statement holds: $h: \mathbb{R}_0^+ \rightarrow \mathbb{R}$, $h(t) = 30 - 4.9 \cdot t^2$ (t in s, $h(t)$ in m).

Task:

Determine the point in time at which the ball is 4 m above the ground.

[0/1 p.]

Task 10

Costs of a Business

The function K with $K(x) = 100 \cdot x^3 - 1800 \cdot x^2 + 11200 \cdot x + 20000$ gives the total cost in euros to a company when it produces x (in tonnes) of a particular product.

Task:

Determine the production amount (in tonnes) for which the total cost is € 48,000 higher than the fixed costs.

[0/1 p.]

Task 11

Height of a Tree

The height of a particular tree can be modelled by an exponential function for the first 15 years after planting.

This tree has a height of 2.2 m 10 years after planting and a height of 2.7 m 15 years after planting.

Task:

Determine the height of this tree at the time of planting.

[0/1 p.]

Task 12

Graph of a Sine Function

The diagram below shows the graph of the sine function f with $f(x) = a \cdot \sin(b \cdot x)$ with $a, b \in \mathbb{R}^+$.

The graph of f goes through the points $P_1 = (3\pi, 3)$ and $P_2 = (4\pi, 0)$.

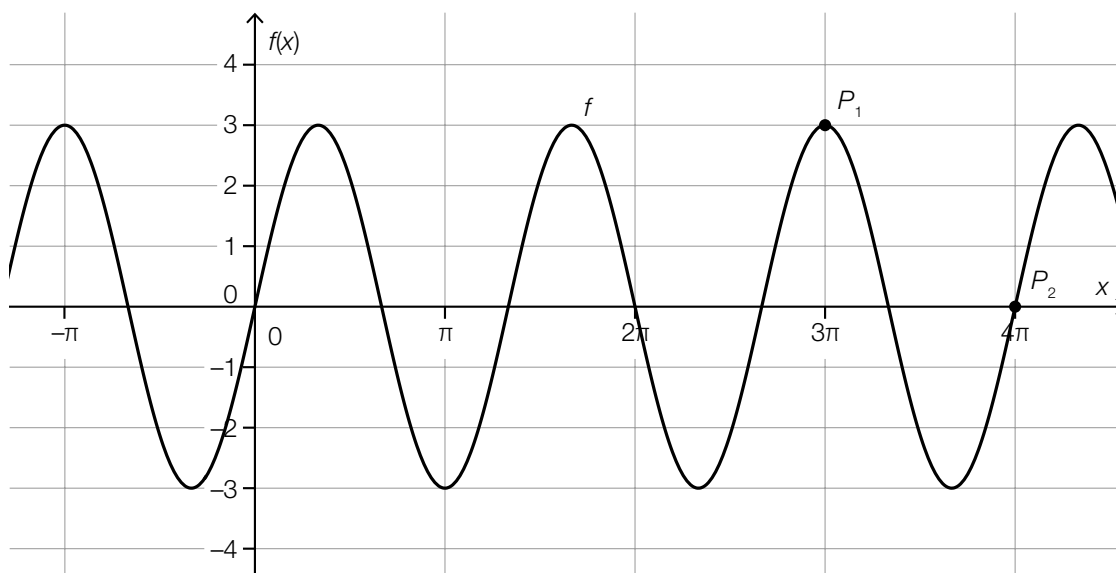

Task:

Write down the values of a and b .

$a =$ _____

$b =$ _____

[0/1/2/1 p.]

Task 13

Population Growth

In a particular country, the population has increased rapidly since 1960.
 $B(t)$ gives the population of this country in year t .

Task:

Interpret $\frac{B(2017) - B(1960)}{B(1960)} = 3.23$ in the given context.

[0/1 p.]

Task 14

Fuel Consumption

The function V describes the amount of fuel in the tank of a car in terms of the distance x covered. After a journey of x kilometres, there are $V(x)$ litres of fuel in the tank.

The car has completed a journey of 180 km without refuelling.

Task:

Using the function V , write down an expression that can be used to calculate the average fuel consumption (in litres per kilometre) for this journey.

[0/1 p.]

Task 15

Differentiation Rules

Let $g: \mathbb{R} \rightarrow \mathbb{R}$ and $h: \mathbb{R} \rightarrow \mathbb{R}$ be differentiable functions and $k \in \mathbb{R}$.

Task:

Put a cross next to each of the two statements that are always true. [2 out of 5]

For the real function f with $f(x) = g(x) - h(x)$ the statement $f'(x) = g'(x) - h'(x)$ holds.	<input type="checkbox"/>
For the real function f with $f(x) = h(k \cdot x)$ the statement $f'(x) = h'(k \cdot x)$ holds.	<input type="checkbox"/>
For the real function f with $f(x) = k \cdot g(x)$ the statement $f'(x) = k \cdot g'(x)$ holds.	<input type="checkbox"/>
For the real function f with $f(x) = g(x) + k$ the statement $f'(x) = g'(x) + k \cdot x$ holds.	<input type="checkbox"/>
For the real function f with $f(x) = g(x) + h(x)$ the statement $f'(x) = g'(x) \cdot h'(x)$ holds.	<input type="checkbox"/>

[0/1 p.]

Task 16

Overtaking

The acceleration of a particular vehicle whilst it is overtaking is described by the function a .

The following statement holds:

$$a(t) = -t^3 + 3 \cdot t^2 \quad \text{with} \quad 0 \leq t \leq 3$$

t ... time since the vehicle starts to overtake in s

$a(t)$... acceleration of the vehicle at time t in m/s^2

The function v assigns each time t to the velocity of the vehicle $v(t)$ (in m/s).

When the vehicle starts to overtake, the vehicle's velocity is $v(0) = 20 \text{ m/s}$.

Task:

Write down an equation of the function v .

[0/1 p.]

Task 17

Second Derivative

The diagram below shows the graph of the 2nd derivative f'' of a 3rd degree polynomial function f . The graph of f'' is a straight line that goes through the origin.

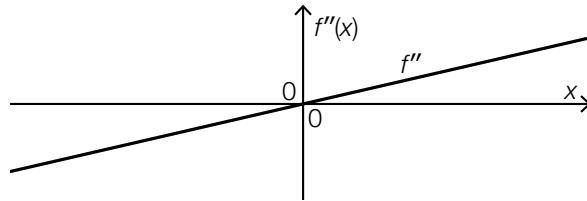

Task:

Put a cross next to each of the two diagrams that could represent the graph of a polynomial function f as described above. [2 out of 5]

	<input type="checkbox"/>
	<input type="checkbox"/>
	<input type="checkbox"/>
	<input type="checkbox"/>
	<input type="checkbox"/>

[0/1 p.]

Task 18

Definite Integral

Each of the four diagrams below shows the graph of the quadratic function f . The graph of f crosses the x -axis at $x = -1$ and $x = 2$. The local minimum of f is at $x = 0.5$.

Task:

Match each of the areas shaded in grey in the four diagrams to the corresponding expression that can be used to calculate the size of the area from A to F.

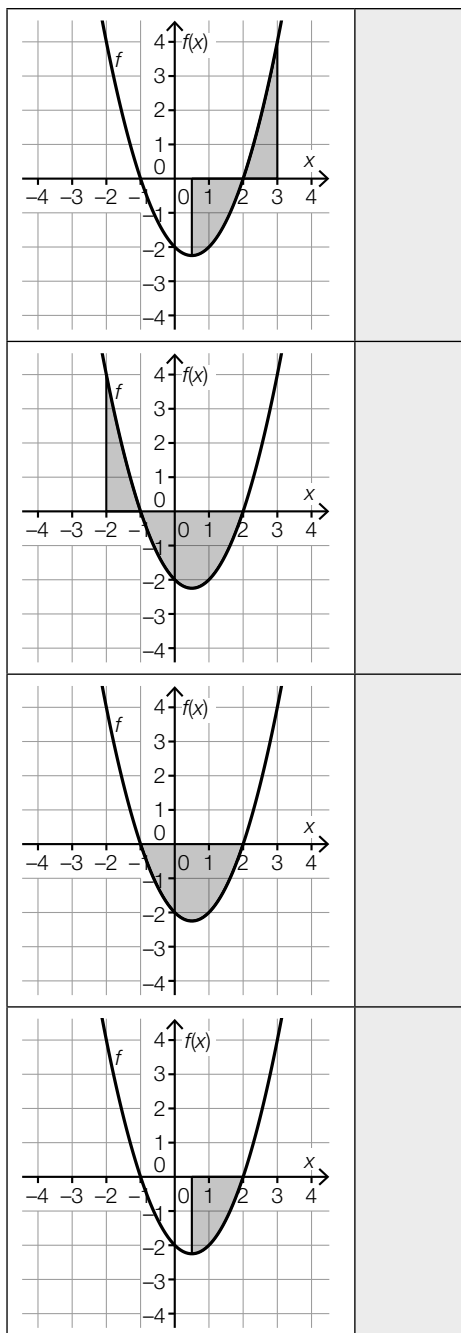

A	$-\int_{0.5}^2 f(x) dx$
B	$-\int_{0.5}^2 f(x) dx + \int_2^3 f(x) dx$
C	$\int_{-2}^{-1} f(x) dx + \int_{-1}^2 f(x) dx$
D	$\int_{-2}^{-1} f(x) dx - \int_{-1}^2 f(x) dx$
E	$\int_{-2}^{0.5} f(x) dx$
F	$-2 \cdot \int_{0.5}^2 f(x) dx$

Task 19

Course Participation

In the time period from 2015 to 2020, a particular course was offered every year in an educational institution. The table below shows the number of course participants for each year in this time period. The number of course participants in 2016 is given by x .

year	number of course participants
2015	12
2016	x
2017	11
2018	12
2019	12
2020	15

The mean number of course participants in the time period from 2015 to 2020 is 12.

Task:

Determine x .

[0/1 p.]

Task 20

Success and Failure

A particular random experiment comprises n independent trials ($n \in \mathbb{N} \setminus \{0\}$). Each trial results in “success” with a probability of p ; otherwise the trial results in “failure”.

Task:

Describe a possible event E for this random experiment that occurs with probability $1 - (1 - p)^n$.

[0/1 p.]

Task 21

Coin Toss

A random experiment involves tossing a coin many times. After each toss, the coin shows either “heads” or “tails”. The probability that the coin shows “heads” is equal to the probability that it shows “tails” after each toss. The results of the tosses are independent of each other. The coin is tossed as many times as it takes until the second “heads” or the second “tails” appears.

The random variable X describes the number of required tosses.

Task:

Determine the probability $P(X = 3)$.

[0/1 p.]

Task 22

Binomial Coefficient

$\binom{10}{2}$ is a binomial coefficient.

Task:

Put a cross next to each of the two amounts that correspond to the binomial coefficient $\binom{10}{2}$.
[2 out of 5]

the amount of two-element subsets of a set with ten elements	<input type="checkbox"/>
the amount of numbers that can be created with two digits	<input type="checkbox"/>
the amount of possible ways of selecting two people from a group of ten people	<input type="checkbox"/>
the amount of possible results when a coin is tossed ten times	<input type="checkbox"/>
the amount of possible results when two ten-sided dice each with the numbers from 1 to 10 on their faces are rolled	<input type="checkbox"/>

[0/1 p.]

Task 23

Probability Distribution

The diagram below shows the probability distribution for the random variable X .

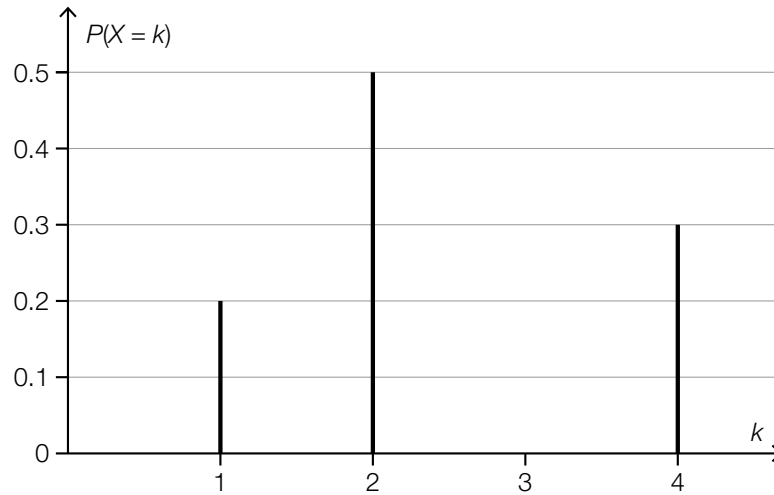

The random variable X only takes the values 1, 2 and 4 with a positive probability.

Task:

Determine the expected value $E(X)$.

[0/1 p.]

Task 24

Wheel of Fortune

A wheel of fortune with 24 equally sized sectors is spun. Two of the sectors are green; all the others are red.

For each spin:

- The pointer lands in each sector with equal probability.
- If the pointer lands in a green sector, a prize is won.
- If the pointer lands in a red sector, no prize is won.

The wheel of fortune is spun n times. The results of the spins are independent of each other.

Task:

Write down the expected value for the number of prizes won in terms of n .

[0/1 p.]

Task 1

Rational Numbers

Statements about rational numbers are shown below.

Task:

Put a cross next to each of the two correct statements. [2 out of 5]

The statement $a + b \geq 0$ holds for all rational numbers a and b .	<input type="checkbox"/>
For each rational number a , there exists a rational number b such that the statement $a + b = 0$ holds.	<input type="checkbox"/>
There are rational numbers a and b for which $a \cdot b < b$ holds.	<input type="checkbox"/>
If exactly one of the two rational numbers a and b , $b \neq 0$, is positive, then the quotient $\frac{a}{b}$ is always positive.	<input type="checkbox"/>
If at least one of the two rational numbers a and b is negative, then the product $a \cdot b$ is always negative.	<input type="checkbox"/>

[0/1 p.]

Task 2

Item of Clothing

The price of a particular item of clothing was € 49.90 at the end of the year 2017. At this point in time, it was 17.8 % more expensive than it had been at the beginning of the year 2017.

Task:

Determine the price increase in euros of the item of clothing over the course of the year 2017.

[0/1 p.]

Task 3

School Sport Week

For a school sport week, a school books x rooms with four beds and y rooms with six beds at a youth hostel. All of the rooms that are booked will be fully occupied.

The booking can be described by the system of equations shown below.

$$\text{I: } 4 \cdot x + 6 \cdot y = 56$$

$$\text{II: } x + y = 12$$

Task:

Put a cross next to each of the two correct statements. [2 out of 5]

Exactly 4 rooms with four beds and exactly 6 rooms with six beds are booked.	<input type="checkbox"/>
Fewer rooms with four beds are booked than rooms with six beds.	<input type="checkbox"/>
Exactly 12 rooms are booked.	<input type="checkbox"/>
Beds for exactly 56 people are booked.	<input type="checkbox"/>
Exactly 10 rooms are booked.	<input type="checkbox"/>

[0/1 p.]

Task 4

Vector Equations of Lines

The diagram below shows the two lines g and h . Three points are shown on each of the lines:

$A, B, P \in g$ and $B, C, Q \in h$.

In addition to this, a direction vector for each of the lines is shown.

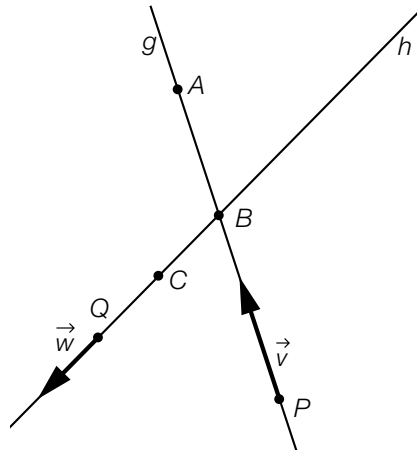

Task:

Put a cross next to each of the two statements for which $s, t \in \mathbb{R}$ with $s \neq 0$ and $t \neq 0$ can be chosen such that the corresponding statement is true. [2 out of 5]

$A = C + s \cdot \vec{v} + t \cdot \vec{w}$	<input type="checkbox"/>
$B = C + s \cdot \vec{v}$	<input type="checkbox"/>
$B = Q + t \cdot \vec{w}$	<input type="checkbox"/>
$A = P + s \cdot \vec{v} + t \cdot \vec{w}$	<input type="checkbox"/>
$C = P + t \cdot \vec{w}$	<input type="checkbox"/>

[0/1 p.]

Task 5

Square

A square has vertices A , B , C and D . The vertex $C = (5, -3)$ and the point of intersection of the diagonals $M = (3, 1)$ are given. The vertices A , B , C and D of the square are labelled in an anti-clockwise direction.

Task:

Determine the coordinates of the vertices A and B .

$A =$ _____

$B =$ _____

[0/1/2/1 p.]

Task 6

Ramp

A ramp with a (sloped) length of d metres has been designed to overcome a vertical rise of h metres ($d > 0, h > 0$). The angle of elevation of the ramp is given by α .

Task:

Put a cross next to each of the two equations that correctly describe the situation. [2 out of 5]

$d = \frac{h}{\sin(\alpha)}$	<input type="checkbox"/>
$d = h \cdot \cos(\alpha)$	<input type="checkbox"/>
$d = \frac{h}{\cos(90^\circ - \alpha)}$	<input type="checkbox"/>
$d = h \cdot \sin(90^\circ - \alpha)$	<input type="checkbox"/>
$d = h \cdot \tan(\alpha)$	<input type="checkbox"/>

[0/1 p.]

Task 7

Ideal Gas

The equation $p \cdot V = n \cdot R \cdot T$ models the relationship between the pressure p , the volume V , the amount of substance n and the absolute temperature T of an ideal gas, whereby R is a constant ($V, n, R \in \mathbb{R}^+$ and $p, T \in \mathbb{R}_0^+$).

The function p models the pressure $p(T)$ in terms of the temperature T when the other quantities given in the equation remain constant.

Task:

In the coordinate system shown below, sketch the graph of one such function p .

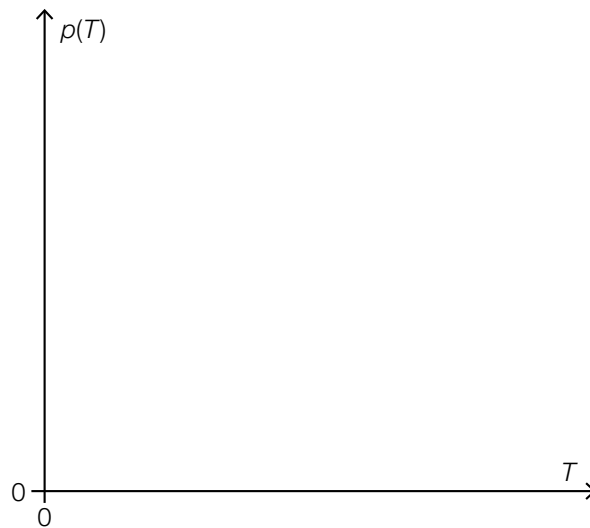

[0/1 p.]

Task 8

Types of Functions

Four types of functions as well as six tables of values of the functions f_1 to f_6 , which each correspond to a particular type of function, are shown below. The values of the function f_1 are rounded to two decimal places.

Task:

Match each of the four types of function shown below to the corresponding table of values (from A to F).

linear function	
quadratic function	
exponential function	
sine function	

A	x	$f_1(x)$
	-2	-0.91
	-1	-0.84
	0	0
	1	0.84
B	x	$f_2(x)$
	-2	8
	-1	2
	0	0
	1	2
C	x	$f_3(x)$
	-2	-7
	-1	-1
	0	0
	1	1
D	x	$f_4(x)$
	-2	0.25
	-1	0.5
	0	1
	1	2
E	x	$f_5(x)$
	-2	-3
	-1	-1
	0	1
	1	3
F	x	$f_6(x)$
	-2	-0.5
	-1	-1
	0	undefined
	1	1
	2	0.5

Task 9

Direct Proportion

The graph of a linear function $f: \mathbb{R} \rightarrow \mathbb{R}$ with $f(x) = m \cdot x + c$ with $m, c \in \mathbb{R}$ goes through the points $A = (x_A, 6)$ and $B = (12, 16)$.

Task:

Determine the coordinate x_A of the point A such that the function f describes a directly proportional relationship.

$x_A =$ _____

[0/1 p.]

Task 10

Quadratic Functions

The diagram below shows the graphs of the two real functions f and g . The following statements hold:

$$f(x) = a \cdot x^2 + b \text{ with } a, b \in \mathbb{R}$$

$$g(x) = c \cdot x^2 + d \text{ with } c, d \in \mathbb{R}$$

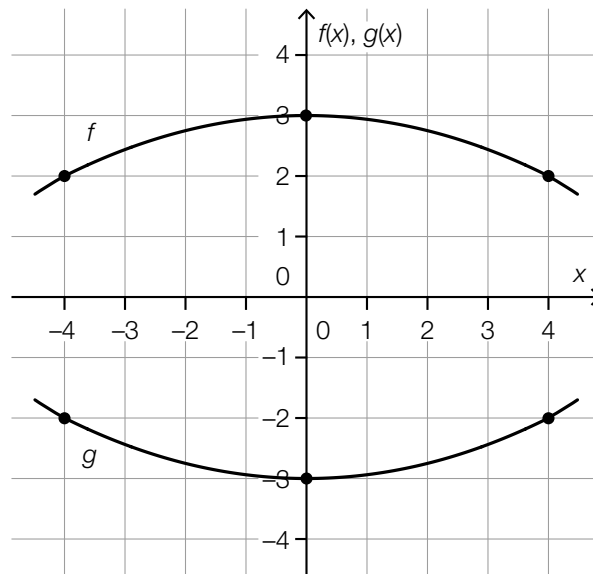

The points shown in bold have integer coordinates.

Task:

Put a cross next to each of the two correct statements. [2 out of 5]

$d = f(0)$	<input type="checkbox"/>
$b = d$	<input type="checkbox"/>
$a = -c$	<input type="checkbox"/>
$-f(x) = g(x)$ for all $x \in \mathbb{R}$	<input type="checkbox"/>
$f(2) = g(2)$	<input type="checkbox"/>

[0/1 p.]

Task 11

Half-Lives of Decay Processes

The three exponential functions N_1 , N_2 and N_3 each describe a decay process with the corresponding half-lives τ_1 , τ_2 and τ_3 .

Sections of the graphs of these three functions are shown below.

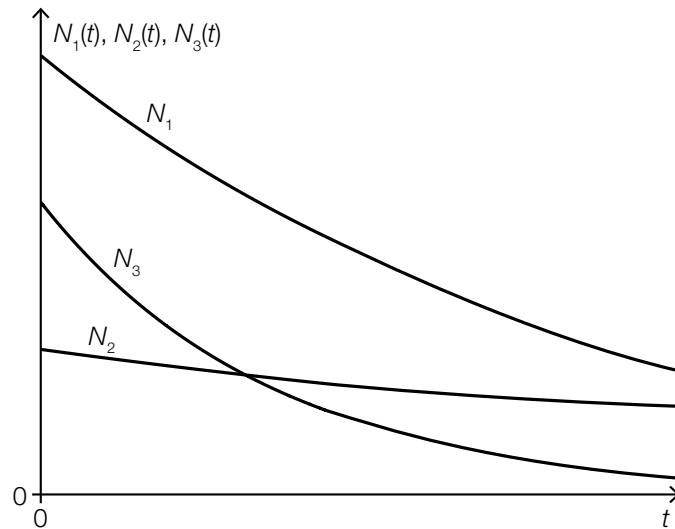

Task:

Write down the half-lives τ_1 , τ_2 and τ_3 in increasing order of magnitude. Start with the shortest half-life.

_____ < _____ < _____

[0/1 p.]

Task 12

Equation of a Function

The following information is known about a real function $f: \mathbb{R} \rightarrow \mathbb{R}^+$:

- $f(1) = 3$
- For all real numbers x , $f(x + 1)$ is 50 % greater than $f(x)$.

Task:

Write down the equation of one such function f .

$f(x) =$ _____

[0/1 p.]

Task 13

Diet

Hannes went on a diet that lasted ten weeks. At the start of each week and at the end of the diet, he recorded his body mass (in kg). These values are shown in the diagram below.

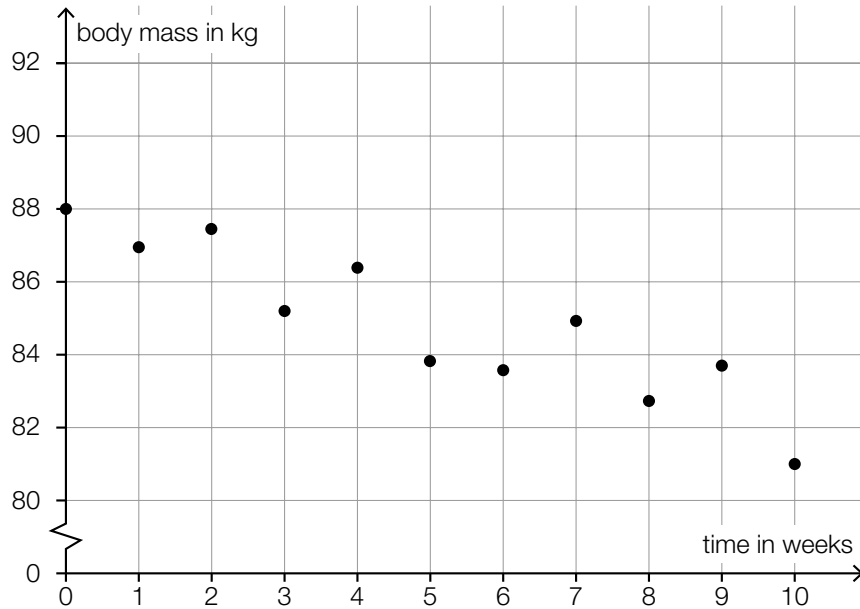

Task:

Write down the absolute change (in kg) and the relative change (in %) of Hannes's body mass from the beginning to the end of the diet.

absolute change: _____ kg

relative change: _____ %

[0/½/1 p.]

Task 14

Rates of Change of a Polynomial Function

The diagram below shows the graph of a polynomial function f and the point $A = (x_1, f(x_1))$ on the graph of f .

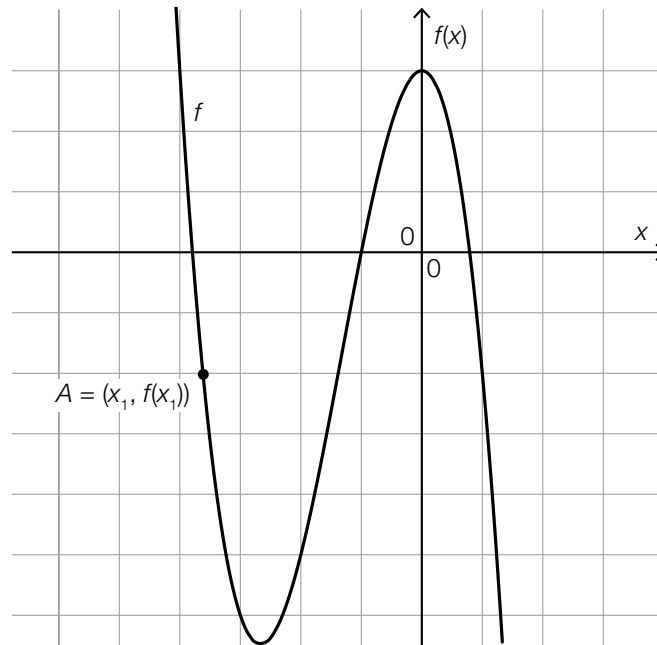

For an x_2 on the diagram above with $x_2 > x_1$, the following conditions hold:

- The differential quotient of f at x_2 is negative.
- The difference quotient of f in the interval $[x_1, x_2]$ is zero.

Task:

In the diagram above, label the point $P = (x_2, f(x_2))$ for which both of the conditions given above are fulfilled.

[0/1 p.]

Task 15

Carp

The number of carp in a pond should be restricted to 800 carp. For modelling purposes, it is assumed that the number of carp increases each year by 7 % of the difference from the maximum number of 800 carp.

The number of carp after n years is given by $F(n)$ and $F(0) = 500$ holds.

Task:

Put a cross next to the difference equation that correctly describes the development of the number of carp. [1 out of 6]

$F(n + 1) = F(n) + 0.07 \cdot (800 - F(n))$	<input type="checkbox"/>
$F(n) = F(n + 1) + 0.07 \cdot (800 - F(n + 1))$	<input type="checkbox"/>
$F(n + 1) = F(n) + 1.07 \cdot (800 - F(n))$	<input type="checkbox"/>
$F(n + 1) = F(n) + 0.07 \cdot (F(n) - 800)$	<input type="checkbox"/>
$F(n + 1) = 800 - 0.07 \cdot F(n)$	<input type="checkbox"/>
$F(n) = 800 - 0.07 \cdot F(n + 1)$	<input type="checkbox"/>

[0/1 p.]

Task 16

Definite Integral

The function F is an antiderivative of the polynomial function f .

Task:

Put a cross next to the expression that definitely corresponds to $\int_2^5 f(x) dx$. [1 out of 6]

$\frac{F(5) - F(2)}{5 - 2}$	<input type="checkbox"/>
$\frac{F(5) - F(2)}{F(2)}$	<input type="checkbox"/>
$F(5) - F(2)$	<input type="checkbox"/>
$F(5) + F(2)$	<input type="checkbox"/>
$\frac{F(2) + F(5)}{2}$	<input type="checkbox"/>
$\frac{F(5)}{F(2)}$	<input type="checkbox"/>

[0/1 p.]

Task 17

Properties of a Function

The diagram below shows the graph of the first derivative f' of a polynomial function f .

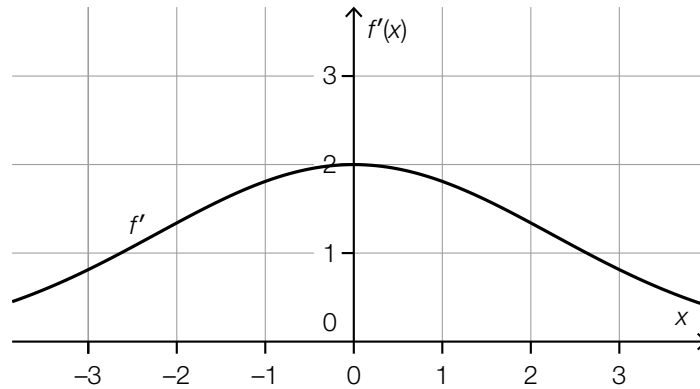

Task:

Put a cross next to each of the two statements that are definitely true about the function f .

[2 out of 5]

In the interval $[-3, 3]$ the function f is strictly monotonically increasing.	<input type="checkbox"/>
The graph of f is symmetrical about the vertical axis in the interval $[-3, 3]$.	<input type="checkbox"/>
The function f has at least one point of inflexion in the interval $[-3, 3]$.	<input type="checkbox"/>
In the interval $[-3, 3]$ all values of the function f are positive.	<input type="checkbox"/>
The function f has at least one local maximum or minimum in the interval $[-3, 3]$.	<input type="checkbox"/>

[0/1 p.]

Task 18

Water Inflow

A container is filled with water for 6 minutes.

The inflow rate gives the number of litres of water that flow into the container per minute.

The inflow rate $Z(t)$ decreases linearly in terms of the time t .

The diagram below shows the graph of the function Z (t in minutes, $Z(t)$ in litres per minute). The points shown in bold have integer coordinates.

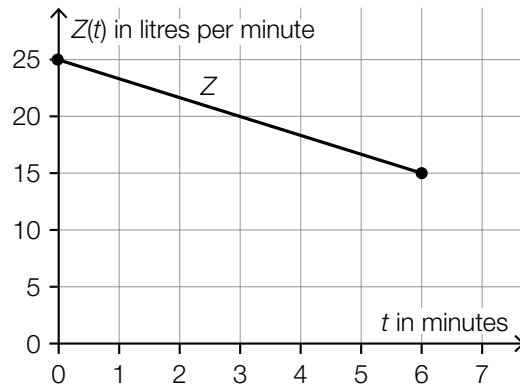

Task:

Determine the number of litres of water that flow into this container in these 6 minutes.

_____ litres

[0/1 p.]

Task 19

Entrance Exam

For a particular entrance exam, the maximum score is 10 points. The bar chart shown below gives the relative frequencies of the points scored as a percentage.

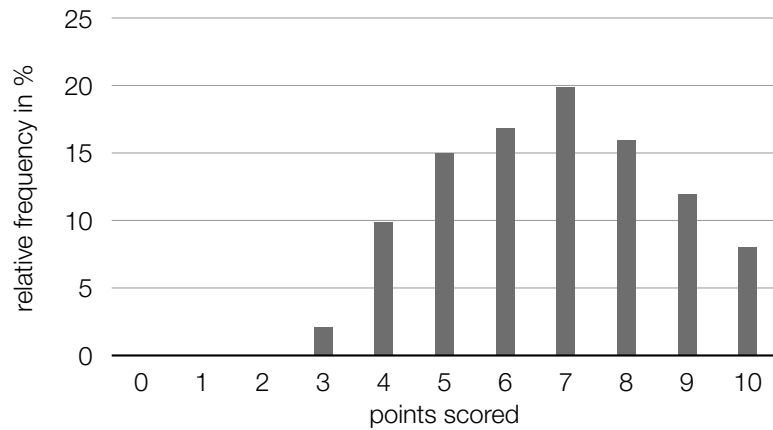

The points scored in the entrance exam are shown in the box plot below.

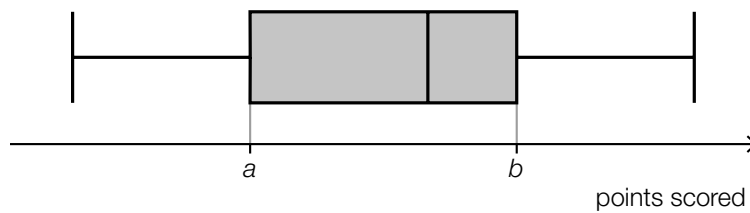

Task:

Determine a and b .

$a =$ _____

$b =$ _____

[0/½/1 p.]

Task 20

Salaries

Seven people work at a small company. Their monthly salaries are given as follows:
€ 1 500, € 2 300, € 1 500, € 1 400, € 4 500, € 2 200, € 1 300.

One more person is to be employed, but the median salary value will not change.

Task:

Based on the information given above, write down the largest possible salary of this additional person.

[0/1 p.]

Task 21

Tossing a Coin

After being tossed, a coin shows either “heads” or “tails”. The probability of the coin showing “heads” is exactly the same as the probability of the coin showing “tails” for each toss. The results of the tosses are independent of each other.

In a random experiment, the coin is tossed 4 times.

Task:

Determine the probability of “heads” occurring more often than “tails” in this random experiment.

[0/1 p.]

Task 22

Probabilities of a Random Variable

A particular random variable X can only take the value -4 , the value 0 or the value 2 .

For the probabilities, the following statements hold:

$$P(X = -4) = 0.3$$

$$P(X = 0) = a$$

$$P(X = 2) = b$$

a and b are positive real numbers.

The expectation value of X is zero i. e. $E(X) = 0$.

Task:

Write down the values of a and b .

$$a = \underline{\hspace{15em}}$$

$$b = \underline{\hspace{15em}}$$

[0/1/2/1 p.]

Task 23

Smoking Behaviour

According to a study, 34 % of all smokers want to quit smoking.

Task:

Interpret the expression shown below in the given context.

$$\binom{200}{57} \cdot 0.34^{57} \cdot 0.66^{143}$$

[0/1 p.]

Task 24

Corked Wine

The flavour of wine can be impaired by a particular substance that can get into the wine from the cork. If this happens, the wine is said to be “corked”.

In a winery, all wine bottles from a particular vintage are sealed with corks from the same production batch. During a later check of 200 wine bottles from this vintage, it is found that the wine in 12 of these bottles is corked.

The relative proportion of corked wine bottles from a sample is given by h .

Task:

For this winery and this vintage, write down a 95 % confidence interval that is symmetrical about h for the unknown relative proportion of wine bottles in which the wine is corked.

[0/1 p.]

Task 1

Difference between Two Natural Numbers

The following statement holds for two natural numbers n and m : $n \neq m$.

For the difference $n - m$ to be a natural number, a particular mathematical relationship between n and m must hold.

Task:

Write down this mathematical relationship.

[0/1 p.]

Task 2

Quadratic Equation

Let $x^2 - 6 \cdot x + c = 0$ with $c \in \mathbb{R}$ be a quadratic equation.

Task:

Determine all $c \in \mathbb{R}$ such that the equation has no real solution.

[0/1 p.]

Task 3

Height

The components of the vector K_1 give the heights of the children of a particular school class (in cm) at the beginning of a school year.

The components of the vector K_2 give the heights of these children (in cm) n months later ($n \in \mathbb{N} \setminus \{0\}$). (The heights given in both vectors K_1 and K_2 are ordered alphabetically by the names of the children.)

Task:

Interpret the vector $\frac{1}{n} \cdot (K_2 - K_1)$ in the given context.

[0/1 p.]

Task 4

Cube and Vector

The diagram below shows a cube whose base $ABCD$ lies in the xy -plane.

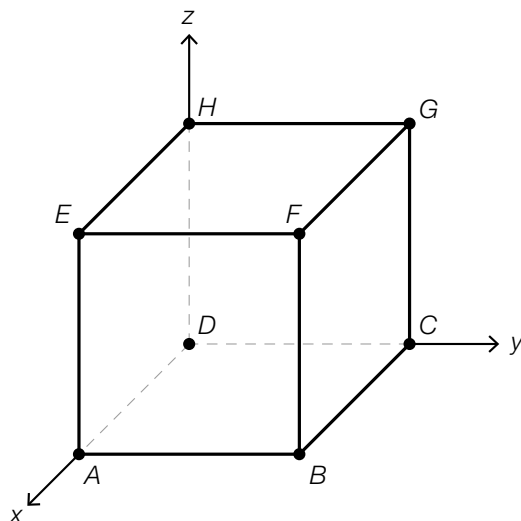

Two vertices of this cube constitute a particular vector that goes in the direction of the vector $\vec{v} = \begin{pmatrix} 1 \\ -1 \\ -1 \end{pmatrix}$.

Task:

Put a cross next to this vector. [1 out of 6]

\vec{EC}	<input type="checkbox"/>
\vec{FD}	<input type="checkbox"/>
\vec{GA}	<input type="checkbox"/>
\vec{GD}	<input type="checkbox"/>
\vec{HA}	<input type="checkbox"/>
\vec{HB}	<input type="checkbox"/>

Task 5

Vectors

The vectors \vec{a} and \vec{c} are shown in the coordinate system below.
The following statement holds: $\vec{c} = 2 \cdot \vec{a} + \vec{b}$.

Task:

Draw the vector \vec{b} into the coordinate system below.

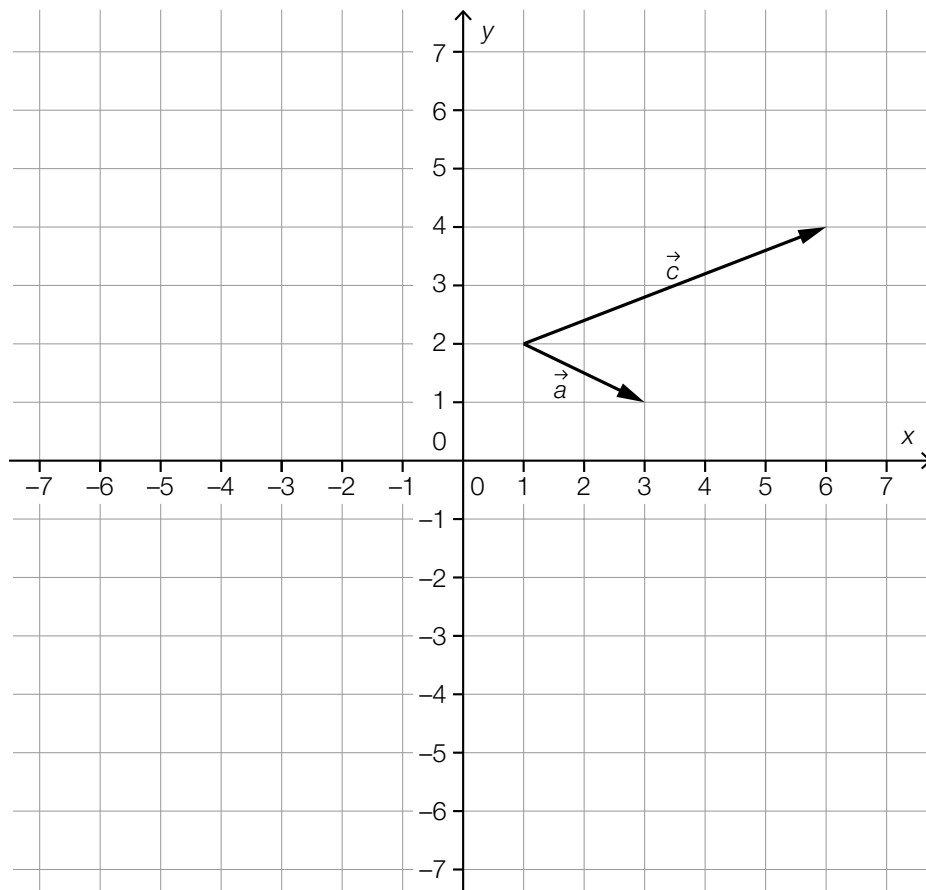

[0/1 p.]

Task 6

Angles and Sides of Right-Angled Triangles

For particular right-angled triangles, the following statements hold:

The angles α , β and γ are opposite the sides a , b and c in this order.

The angles are measured in degrees and the side lengths are measured in centimetres.

Furthermore, $\cos(\alpha) = \frac{3}{5}$ and $\cos(\gamma) = 0$ hold.

Task:

Put a cross next to each of the two statements that are true for every one of these triangles.

[2 out of 5]

$c = 5 \text{ cm}$	<input type="checkbox"/>
$\beta < 90^\circ$	<input type="checkbox"/>
$\sin(\beta) = \frac{3}{5}$	<input type="checkbox"/>
$a < b < c$	<input type="checkbox"/>
$\tan(\alpha) = 0.75$	<input type="checkbox"/>

[0/1 p.]

Task 7

Shirts

A company produces and sells shirts.

The linear function K describes the costs $K(x)$ in euros in terms of the number x of items produced.

The linear function E describes the revenue $E(x)$ in euros in terms of the number x of items sold.

The diagram below shows the graph of the function K and the graph of the function E .

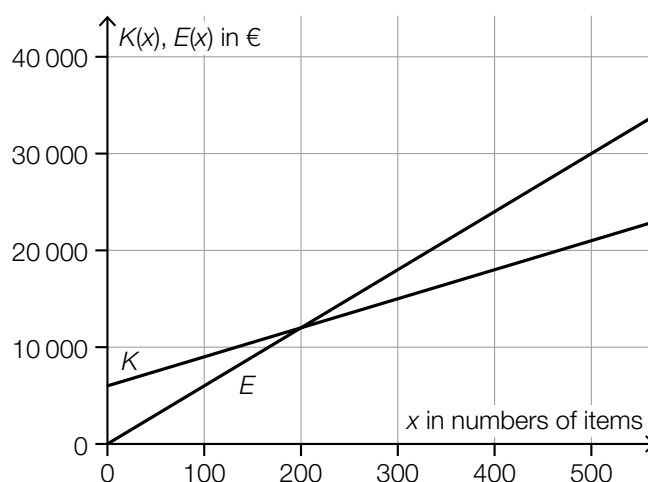

The point of intersection of K and E has coordinates $(200, 12000)$ and $K(0) = 6000$ holds.

Task:

Put a cross next to each of the two true statements. [2 out of 5]

The sales price of a shirt is € 60.	<input type="checkbox"/>
The production cost of a shirt is € 25.	<input type="checkbox"/>
If the company produces and sells 400 shirts, a profit of € 6000 will be made.	<input type="checkbox"/>
There are no fixed costs in the production.	<input type="checkbox"/>
If the company produces and sells fewer than 200 shirts, a profit will be made.	<input type="checkbox"/>

[0/1 p.]

Task 8

Revenue Function

For a particular product, the relationship between the amount in demand x and the demand price $p(x)$ can be modelled by the linear function p shown below.

x ... amount in demand in units of quantity, $0 \leq x \leq 12$

$p(x)$... demand price for the amount x in monetary units per unit of quantity (GE/ME)

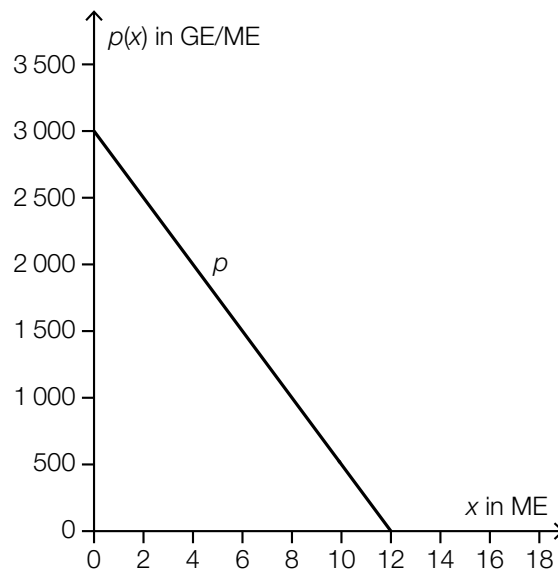

For the revenue function E , the following statement holds: $E(x) = p(x) \cdot x$.

Task:

Write down an equation of the function E .

$E(x) =$ _____

[0/1 p.]

Task 9

Expansion of a Bridge

The length of a particular bridge is dependent on its temperature.

At a temperature of the bridge of $-14\text{ }^{\circ}\text{C}$, it is 300 m long.

When the bridge warms up by $25\text{ }^{\circ}\text{C}$, it expands by 0.1 m.

The linear function l models the length of the bridge in terms of its temperature T . Each temperature $T \in [-20\text{ }^{\circ}\text{C}, 40\text{ }^{\circ}\text{C}]$ is associated with the length of the bridge $l(T)$ (T in $^{\circ}\text{C}$, $l(T)$ in m).

Task:

Write down an equation of the function l .

$l(T) =$ _____

[0/1 p.]

Task 10

Two Quadratic Functions

A particular cross-section is bounded by the graphs of the quadratic functions f_1 and f_2 as well as the lines $x = -4$ and $x = 4$.

The following statements hold:

$$f_1: [-4, 4] \rightarrow \mathbb{R}, x \mapsto a \cdot x^2 + b \text{ with } a, b \in \mathbb{R}$$

$$f_2: [-4, 4] \rightarrow \mathbb{R}, x \mapsto c \cdot x^2 + d \text{ with } c, d \in \mathbb{R}$$

The situation is represented in the diagram below.

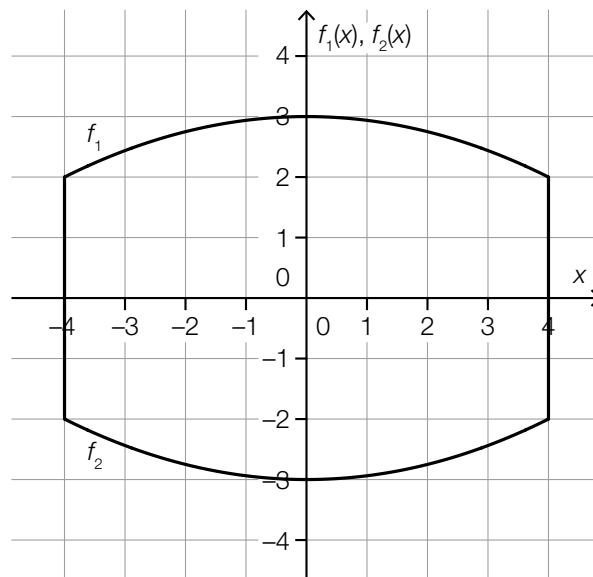

Task:

Complete the statements (1) and (2) below by choosing from the symbols " $<$ ", " $=$ " or " $>$ " so that each sentence becomes a correct statement.

(1) a _____ c

(2) b _____ d

[0/1½/1 p.]

Task 11

Medication

The pain-relieving active ingredient of a medication reduces in the body of a particular patient approximately exponentially. The amount of active ingredient decreases by 8 % per hour. At time $t = 0$ the amount of active ingredient is 700 micrograms.

Task:

Determine after which period of time (in h) the active ingredient in the body of the patient has reduced to 100 micrograms.

[0/1 p.]

Task 12

Half-Life

The diagram below shows a model of the development of the radiation intensity of a particular radioactive substance in terms of time.

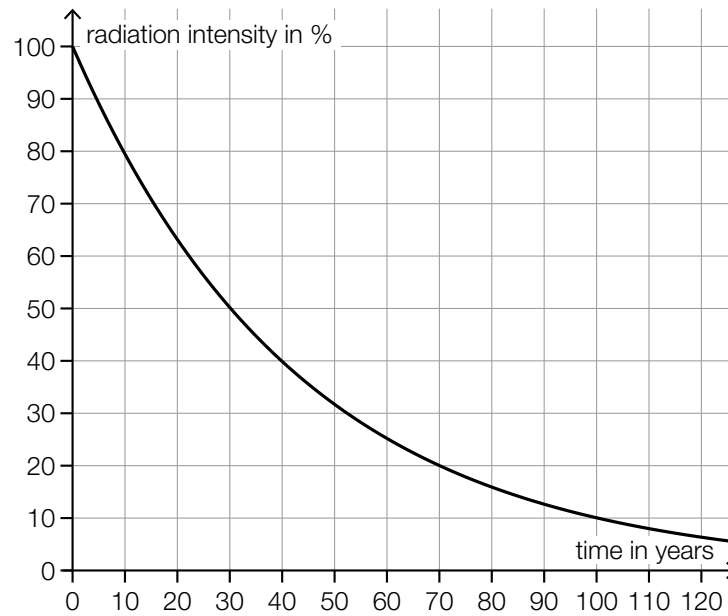

Task:

Write down the half-life T of the radioactive intensity of this radioactive substance.

$T =$ _____ years

[0/1 p.]

Task 13

Cooling

The differentiable function T assigns the time $t \geq 0$ to the temperature $T(t)$ of a body (t in h, $T(t)$ in °C).

The diagram below shows the graph of this function T .

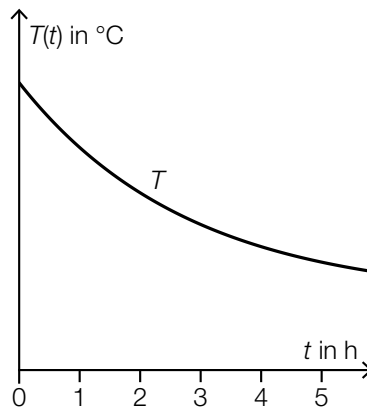

The following statement holds: $T'(1) = -15$.

Task:

Put a cross next to each of the two true statements. [2 out of 5]

At the time $t = 2$, the instantaneous rate of change of the temperature of the body is smaller than -15 °C/h.	<input type="checkbox"/>
The temperature of the body one hour after the start of the cooling process is 15 °C lower than at the time $t = 0$.	<input type="checkbox"/>
At the time $t = 1$, the instantaneous rate of change of the temperature of the body is -15 °C/h.	<input type="checkbox"/>
The following statement holds: $\frac{T(3) - T(1)}{2} > -15$.	<input type="checkbox"/>
Over the course of the first hour, the average speed of cooling of the body is 15 °C/h.	<input type="checkbox"/>

[0/1 p.]

Task 14

Difference Equation

Let $x_{n+1} = 1.2 \cdot x_n - 2$ with $n \in \mathbb{N}$ be a difference equation with the starting value $x_0 \in \mathbb{R}$.

Task:

Write down a formula that could be used to calculate x_2 in terms of x_0 .

[0/1 p.]

Task 15

Derivative and Antiderivative

The polynomial function f has the derivative f' and the antiderivative F .

Task:

Put a cross next to each of the two statements that are true in all cases. [2 out of 5]

The expression $F(a)$ gives the gradient of f at the point $(a, f(a))$ for all $a \in \mathbb{R}$.	<input type="checkbox"/>
The antiderivative F is unique. There exist no other antiderivatives of f .	<input type="checkbox"/>
The derivative f' is unique. There exist no other derivatives of f .	<input type="checkbox"/>
The expression $F'(0)$ gives the gradient of the function f at the point $(0, f(0))$.	<input type="checkbox"/>
The following statement holds: $F'(a) = f(a)$ for all $a \in \mathbb{R}$.	<input type="checkbox"/>

[0/1 p.]

Task 16

Derivatives

The graph of the 3rd degree polynomial function f is shown below. The points marked in bold (the minimum T , the point of inflexion W and the maximum H) have integer coordinates.

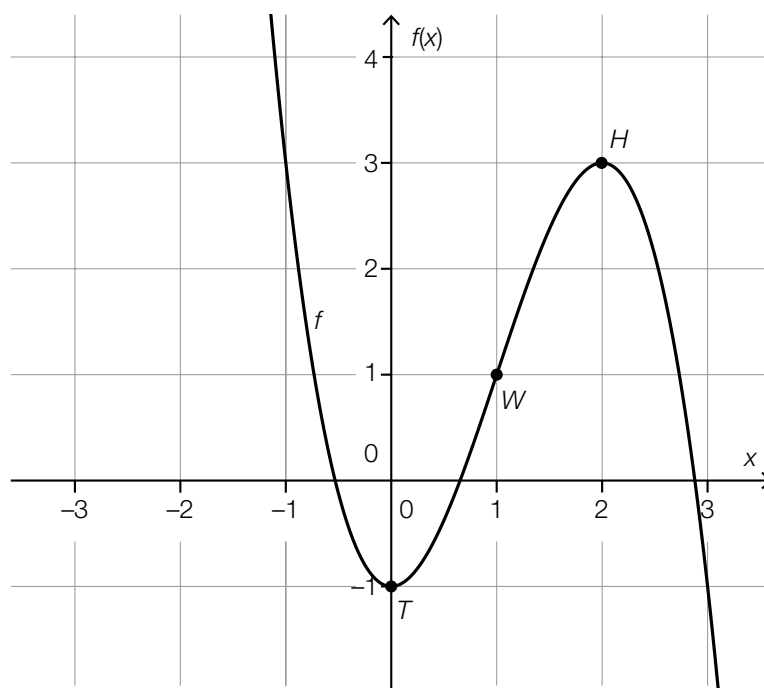

Various statements about the 1st and 2nd derivatives of f are shown below.

Task:

Put a cross next to each of the two true statements. [2 out of 5]

$f'(0) > 0$	<input type="checkbox"/>
$f''(0) > 0$	<input type="checkbox"/>
$f'(1) > 0$	<input type="checkbox"/>
$f'(2) > 0$	<input type="checkbox"/>
$f''(2) > 0$	<input type="checkbox"/>

[0/1 p.]

Task 17

Petrol Consumption on a Journey on a Country Road

Maria drives her car on a country road for a distance of 10 km.

The function b gives the instantaneous petrol consumption $b(s)$ (in L/km) in terms of the distance covered s (in km) from the start of the journey (see diagram below).

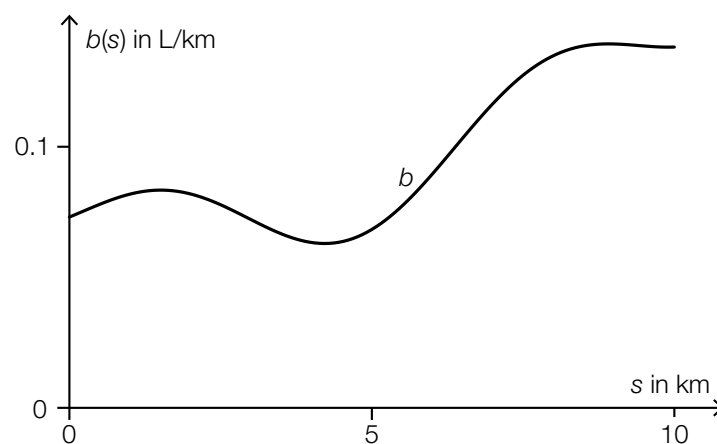

The expression V has units L/km and can be calculated using the formula shown below.

$$V = \frac{1}{10} \cdot \int_0^{10} b(s) ds$$

Task:

Interpret V in the given context.

[0/1 p.]

Task 18

Statements about Definite Integrals

The diagram below shows the graph of the function f in the interval $[0, 6]$.

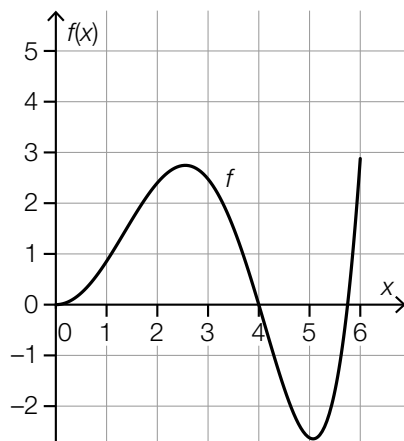

Various statements about definite integrals of the function f are shown below.

Task:

Put a cross next to each of the two true statements. [2 out of 5]

$\int_0^4 f(x) dx > \int_0^5 f(x) dx$	<input type="checkbox"/>
$\int_3^4 f(x) dx > \int_4^5 f(x) dx$	<input type="checkbox"/>
$\int_0^6 f(x) dx > \int_0^4 f(x) dx$	<input type="checkbox"/>
$\int_0^4 f(x) dx = 0$	<input type="checkbox"/>
$\int_4^6 f(x) dx > 0$	<input type="checkbox"/>

[0/1 p.]

Task 19

Results of a Mathematics Examination

For a particular mathematics examination, in which 30 pupils participated, the maximum possible score was 48 points.

The results of this mathematics examination are represented below in a boxplot and a stem and leaf diagram.

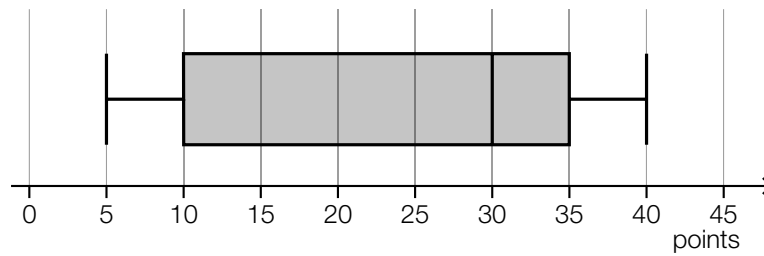

tens digit	units digit
0	$a, 6, 6, 7, 7, 8, 8$
1	$0, 1, 5, 5, 9$
2	$1, 5, 8$
3	$b, 3, 3, 3, 3, 4, 4, 5, 5, 7, 8, 8, 9$
4	$0, 0$

Task:

Write down the values of a and b .

$a =$ _____

$b =$ _____

[0/1½/1 p.]

Task 20

Changing Numbers

A particular list of data comprises 100 numbers x_1, x_2, \dots, x_{100} . The mean of the list of data is 86, the minimum value is 29, and the maximum value is 103.

A second list of data also comprises 100 numbers. This list is generated by subtracting 20 from each number in the original list of data.

Task:

Write down the mean and the range of the second list of data.

mean: _____

range: _____

[0/1/2/1 p.]

Task 21

Two-Step Random Experiment

A random experiment can either result in a “success” with a probability of p or a “failure” with a probability of $1 - p$.

This random experiment is conducted twice. Each experiment is independent of the other. The probability that at least one of these experiments results in a “success” is 0.36.

Task:

Determine the probability p .

[0/1 p.]

Task 22

Selection Possibilities

In a particular competition, annual passes for the zoo can be won.

In this competition, 1 000 people have each participated 1 time.

To determine the winners, two people are selected at random.

Task:

Write down the number of possibilities of randomly selecting these 2 people from the 1 000 participants.

The number of selection possibilities is: _____

[0/1 p.]

Task 23

Short-Sightedness

The approximately normally distributed random variable X gives the number of short-sighted people in a sample. The function f is the density function of the random variable X and takes its maximum value when $x = 2000$. The graph of f is shown in the diagram below.

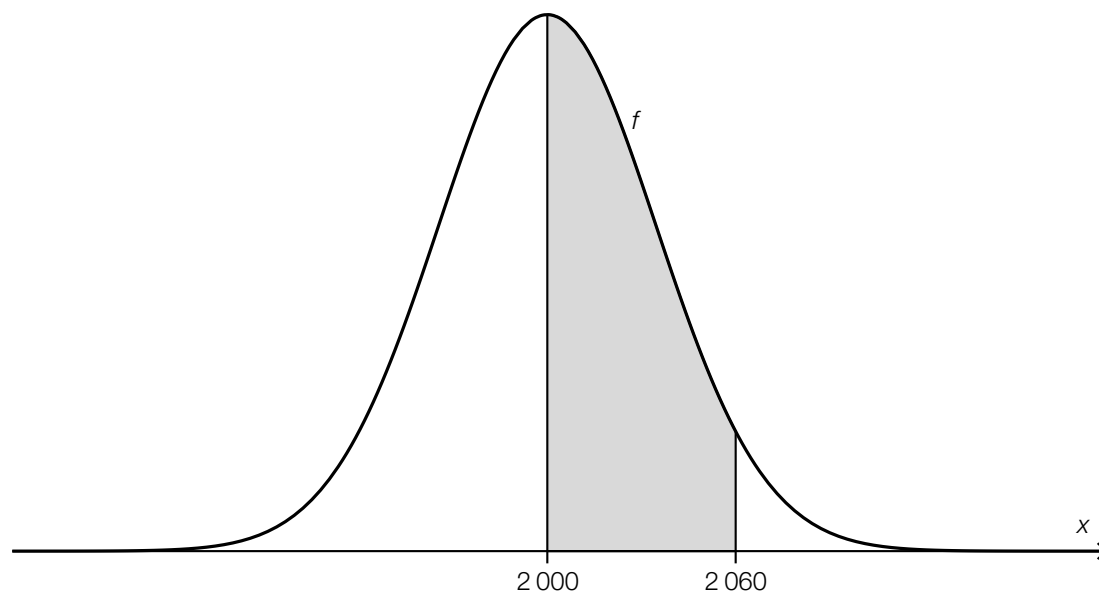

The area of the region shaded in grey is 0.46.

Task:

Write down the probability that there are at least 2060 short-sighted people in this sample.

$P(\text{"at least 2060 short-sighted people"}) =$ _____

[0/1 p.]

Task 24

Binomially Distributed Random Variable

A particular random experiment with an unknown probability of success p is conducted 400 times. The binomially distributed random variable X gives the number of successes. For the expectation value the following statement holds: $\mu = 80$.

Task:

Determine the probability of success p as well as the standard deviation σ of the random variable X .

$$p = \underline{\hspace{10cm}}$$

$$\sigma = \underline{\hspace{10cm}}$$

[0/1/2/1 p.]

Task 1

Representations of Numbers

There are various ways of representing numbers. For example, $\frac{1}{2} = 0.5$ can be represented as a terminating decimal number, or $\frac{1}{6} = 0.1\dot{6}$ can be represented as a recurring decimal number.

Statements about the possible representations of various numbers are shown below.

Task:

Put a cross next to each of the two correct statements. [2 out of 5]

Every rational number can be represented as a terminating decimal number or a recurring decimal number.	<input type="checkbox"/>
Every real number can be represented as a fraction of two integers.	<input type="checkbox"/>
Every fraction of two integers can be represented as a terminating decimal number.	<input type="checkbox"/>
There are rational numbers that cannot be represented as a fraction of two integers.	<input type="checkbox"/>
There are square roots of natural numbers that cannot be represented as a fraction of two integers.	<input type="checkbox"/>

[0/1 p.]

Task 2

Braking

A car travels at a velocity of 30 m/s. The driver applies the brakes until the car comes to a complete stop such that the velocity of the car decreases by b m/s per second.

The time period from when the driver begins to apply the brakes until the car comes to a complete stop is given by t (t in s).

Task:

Write down an equation that describes the relationship between t and b .

[0/1 p.]

Task 3

Parameter of a Quadratic Equation

Let $x^2 + k \cdot x + 4 \cdot k = 0$ be a quadratic equation with parameter $k \in \mathbb{R}$.

Task:

Determine two distinct values k_1 and k_2 of k for which the equation above has exactly one solution.

$$k_1 = \underline{\hspace{10cm}}$$

$$k_2 = \underline{\hspace{10cm}}$$

[0/1/2/1 p.]

Task 4

System of Equations

Equation I of a system of linear equations with two equations in the two variables x and y is shown below.

$$\text{I: } 2 \cdot x + y = 1$$

The system of equations has no solutions.

Task:

Write down an appropriate equation II in x and y .

II: _____

[0/1 p.]

Task 5

Point on a Line

The line g goes through the points A and B and can be described by the equation $g: X = A + t \cdot \overrightarrow{AB}$ with $t \in \mathbb{R}$.

For the point $C \in g$, it is known that $t = -1.5$.

Task:

Plot the point C on the diagram below.

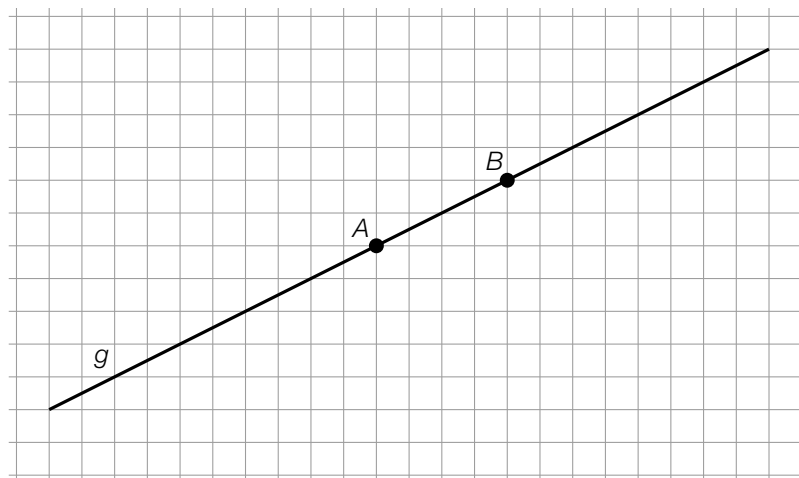

[0/1 p.]

Task 6

Staircase

The diagram below shows a staircase with step height h (in cm), step length l (in cm) and angle of elevation φ .

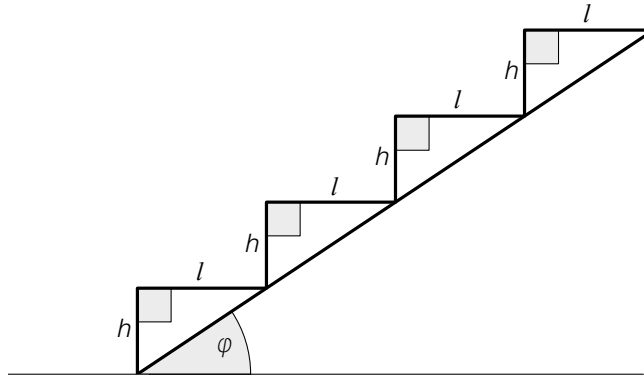

The following conditions must be satisfied:

- $2 \cdot h + l = 63$
- The step length l lies in the interval $[21 \text{ cm}, 36.5 \text{ cm}]$.

Task:

Determine the smallest and largest possible angles of elevation φ (in $^\circ$) such that the conditions stated above are satisfied.

smallest possible angle of elevation φ : _____ $^\circ$

largest possible angle of elevation φ : _____ $^\circ$

[0/1/2/1 p.]

Task 7

Pairs of Values

The diagram below shows the graph of a quadratic function f . The points shown in bold have integer coordinates.

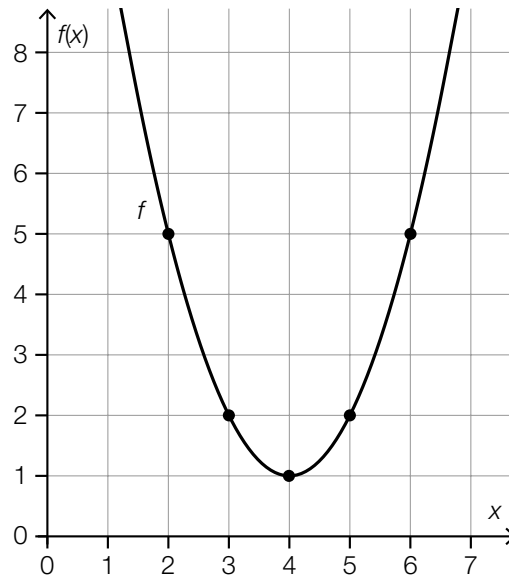

Task:

Complete the following sentence below by putting a cross next to one of the given possibilities for each gap so that the sentence becomes a correct statement.

For _____ ① _____ it holds that $f(x) \leq 5$; for $x \in [3, 5]$, it holds that _____ ② _____.

①	
$x \in [1, 5]$	<input type="checkbox"/>
$x \in [2, 6]$	<input type="checkbox"/>
$x \in [3, 7]$	<input type="checkbox"/>

②	
$f(x) \in [1, 2]$	<input type="checkbox"/>
$f(x) \in [0, 1]$	<input type="checkbox"/>
$f(x) \in [2, 5]$	<input type="checkbox"/>

[0/1½/1 p.]

Task 8

Point of Intersection of a Line with the x -axis

Every equation of the form $y = m \cdot x + c$ with $m, c \in \mathbb{R}$ describes a line in two-dimensional space.

Task:

Write down the conditions that must be satisfied by the parameters m and c of a line such that this line has no point of intersection with the x -axis.

condition for m : _____

condition for c : _____

[0/1/2/1 p.]

Task 9

Areas of Rectangles

The function f assigns the width x (with $x > 0$) of a rectangle with an area of 26 cm^2 to the length $f(x)$ ($x, f(x)$ in cm).

Task:

Write down an equation of the function f .

$f(x) =$ _____

[0/1 p.]

Task 10

Degree of a Polynomial Function

The graph of the polynomial function f is shown below. Outside of the section of the graph shown, f has no zeros, maxima, minima, or points of inflexion.

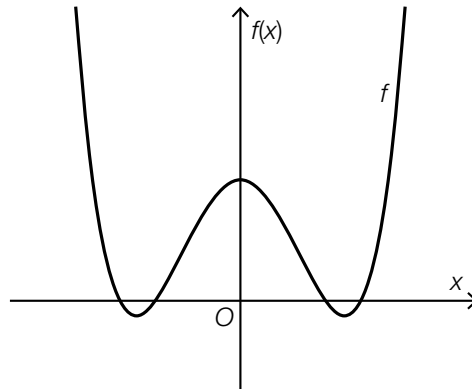

Task:

Justify why the degree of f must be at least 4.

[0/1 p.]

Task 11

Physical Performance

As part of a study, the physical performance of a particular group of people is investigated. The result is given in points. It can be assumed that this point score decreases exponentially as a person ages.

Lena is one of these people. Her scores are shown in the following data set:

age in years	55	60
number of points	1 800	1 650

Task:

Using an exponential model, determine the age from which the model predicts Lena will score at most 1 200 points.

[0/1 p.]

Task 12

Number of Inhabitants

It has been recorded how the number of inhabitants in various cities has changed in the last five years.

Two of the situations given below can be described as exponential growth of the corresponding number of inhabitants.

Task:

Put a cross next to each of the two situations that can be appropriately described with an exponential function. *[2 out of 5]*

The number of inhabitants increased each year by $\frac{1}{10}$ of the number of inhabitants of the previous year.	<input type="checkbox"/>
The number of inhabitants increased by 10 000 in the first year, by 20 000 in the second year, by 30 000 in the third year, by 40 000 in the fourth year and by 50 000 in the last year.	<input type="checkbox"/>
The number of inhabitants was always 5 % greater than in the previous year.	<input type="checkbox"/>
The number of inhabitants was always 20 000 greater than in the previous year.	<input type="checkbox"/>
The number of inhabitants was 5 % greater than in each of the previous years for the first two years and then 15 % greater than in each previous year in subsequent years.	<input type="checkbox"/>

[0/1 p.]

Task 13

Boundary of an Interval

Let f be a function with equation $f(x) = -x^2 + 3 \cdot x + 2$.

In the interval $[0, b]$ (with $b > 0$), the average rate of change of f is exactly zero.

Task:

Determine the boundary of the interval b .

$b =$ _____

[0/1 p.]

Task 14

Grape Juice

A particular container is filled with grape juice. The function f describes how full the container is with grape juice in terms of the time t . The following conditions hold:

- The container is filled without interruption.
- The increase of the liquid in the container slows down continuously (i. e. strictly monotonically).

t ... time since the container began to be filled in s

$f(t)$... how full the container is with grape juice at time t in cm

t_1, t_2 ... two particular times during which the container is being filled with $t_1 < t_2$

Task:

Put a cross next to each of the two true statements. [2 out of 5]

The 1 st derivative of f is positive at time t_1 .	<input type="checkbox"/>
The 1 st derivative of f is negative at time t_2 .	<input type="checkbox"/>
The 1 st derivative of f at time t_1 has the same value as the 1 st derivative of f at time t_2 .	<input type="checkbox"/>
The 2 nd derivative of f is positive at time t_1 .	<input type="checkbox"/>
The 2 nd derivative of f is negative at time t_2 .	<input type="checkbox"/>

[0/1 p.]

Task 15

Velocity-Time Function

The function $v(t)$ gives the velocity of a particular body at time t (t in s, $v(t)$ in m/s). The graph of v is shown in the diagram below.

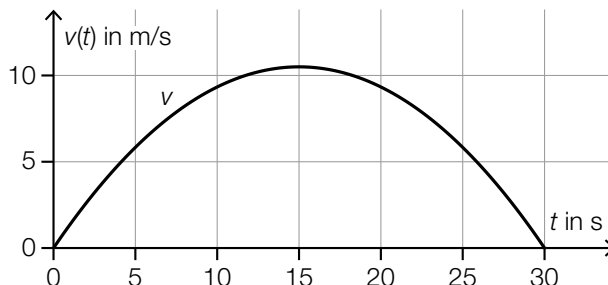

Statements about the distance-time function s and the acceleration-time function a for this movement are shown below (t in s, $s(t)$ in m, $a(t)$ in m/s^2).

Task:

Put a cross next to each of the two true statements. [2 out of 5]

The statement $s(10) < 10$ holds.	<input type="checkbox"/>
There exists a time $t_0 \in [0, 30]$ with $a(t_0) = 0$.	<input type="checkbox"/>
At the time $t = 15$, the acceleration is maximal.	<input type="checkbox"/>
The statement $s(30) - s(0) > 300$ holds.	<input type="checkbox"/>
For all $t_1, t_2 \in [0, 30]$ with $t_2 > t_1$, the statement $s(t_2) > s(t_1)$ holds.	<input type="checkbox"/>

[0/1 p.]

Task 16

Monotonicity and Concavity

Let f be a polynomial function with two x -values x_1 and x_2 where $x_1 < x_2$.
For the first derivative f' of f , the statements $f'(x_1) < 0$ and $f'(x_2) > 0$ hold.

Task:

Put a cross next to each of the two statements that are definitely true. [2 out of 5]

In the interval (x_1, x_2) , there is at least one x -value x_0 for which $f'(x_0) = 0$.	<input type="checkbox"/>
The function f has a local maximum in the interval (x_1, x_2) .	<input type="checkbox"/>
The function f has a point of inflexion in the interval (x_1, x_2) .	<input type="checkbox"/>
The graph of f crosses the x -axis at least once in the interval (x_1, x_2) .	<input type="checkbox"/>
The concavity of f changes in the interval (x_1, x_2) .	<input type="checkbox"/>

[0/1 p.]

Task 17

Definite Integral

The polynomial function $f: \mathbb{R} \rightarrow \mathbb{R}$ has a particular antiderivative F . Pairs of values for this antiderivative F are shown below.

x	$F(x)$
0	0
1	1
2	3
3	6
4	10
5	15

The function $g: \mathbb{R} \rightarrow \mathbb{R}$ with $g(x) = f(x) + 2$ is also given.

Task:

Determine $\int_1^4 g(x) dx$.

[0/1 p.]

Task 18

Inflow and Outflow

The amount of liquid in a particular container changes due to inflow and outflow.

The real function r assigns each point in time $t \in [0, 6]$ to the instantaneous rate of change $r(t)$ of the amount of liquid in this container (t in h, $r(t)$ in l/h).

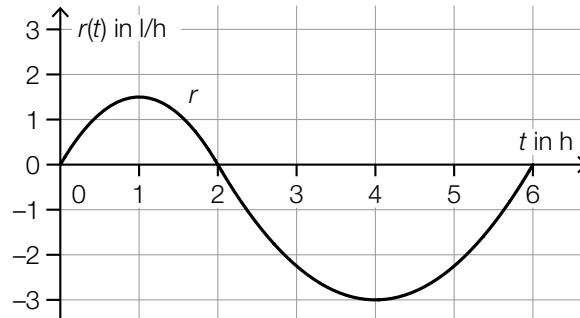

The following statements hold:

$$\int_0^2 r(t) dt = 2 \quad \text{and} \quad \int_2^6 r(t) dt = -8$$

Task:

Put a cross next to each of the two true statements. [2 out of 5]

It is possible that at time $t = 0$ there are exactly 5 l of liquid in the container.	<input type="checkbox"/>
At time $t = 2$, there are exactly 2 l of liquid in the container.	<input type="checkbox"/>
At time $t = 2$, there is the greatest amount of liquid in the container.	<input type="checkbox"/>
At time $t = 4$, there is less liquid in the container than at time $t = 6$.	<input type="checkbox"/>
At time $t = 6$, there are 6 l less liquid in the container than at time $t = 0$.	<input type="checkbox"/>

[0/1 p.]

Task 19

Vocabulary Test

In a test, 16 school pupils are asked to translate 10 words.
The bar chart on the right shows the result of this test.

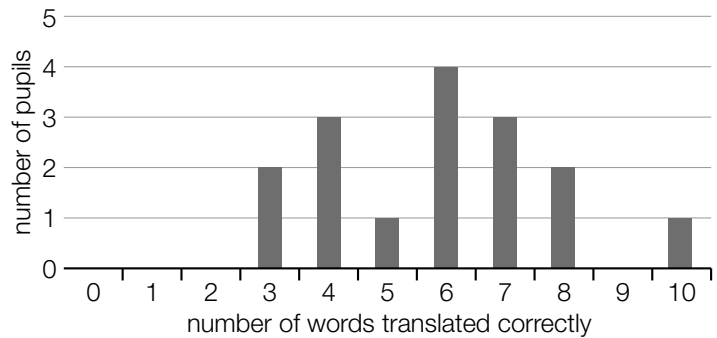

Task:

Put a cross next to the boxplot that correctly displays the data from the bar chart. [1 out of 6]

<p>number of words translated correctly</p>	<input type="checkbox"/>
<p>number of words translated correctly</p>	<input type="checkbox"/>
<p>number of words translated correctly</p>	<input type="checkbox"/>
<p>number of words translated correctly</p>	<input type="checkbox"/>
<p>number of words translated correctly</p>	<input type="checkbox"/>
<p>number of words translated correctly</p>	<input type="checkbox"/>

Task 20

Supplementing a List of Data

A list of data contains the following values:

17, 20, 22, 25, 27, 28, 30, 31

Task:

Supplement the list of data by adding two integer values a and b to the list, so that the median $m = 26$ and the mean $\bar{x} = 25$ remain the same.

$a =$ _____

$b =$ _____

[0/1 p.]

Task 21

Fire Service Call-Outs

The fire services in Lower Austria published the following data about the number of call-outs in the year 2017.

total	65 270
in which the following were mentioned specifically:	
rescue	2 395
fire	4 026
fire safety monitoring	12 708
false alarms	5 283

Data source: <https://www.noen.at/niederoesterreich/chronik-gericht/bilanz-noe-feuerwehren-mussten-im-vorjahr-65-000-mal-ausruecken-bilanz-feuerwehr-noe-feuerwehreinsaetze-79417723> [23.09.2019].

Task:

Using the data provided above, write down the relative frequency h of call-outs that were for a fire.

$h =$ _____

[0/1 p.]

Task 22

Sectors of a Wheel of Fortune

A particular wheel of fortune has three sectors of different sizes. One of these sectors is coloured green, one is coloured red and one is coloured yellow.

The probability that the pointer on the wheel of fortune lands on the yellow sector after being spun takes a constant value p for every spin of the wheel of fortune (independent of the previous spins).

Task:

Describe a possible event in the context described above whose probability can be calculated by $(1 - p)^3$.

[0/1 p.]

Task 23

Competition

A code for a competition is printed on the label of a bottle of drink.

- The probability of winning € 10 with this code is 1 %.
- The probability of winning € 2 with this code is 4 %.

There are no other amounts that can be won.

The random variable X gives the amount of money (in €) won for a code.

Task:

Determine the expectation value $E(X)$.

[0/1 p.]

Task 24

Approximation with the Normal Distribution

A binomially distributed random variable is approximated by the normally distributed random variable X with expectation value μ and standard deviation σ .

Task:

Put a cross next to each of the two expressions whose value is at least 66 %. [2 out of 5]

$P(0 \leq X \leq \mu)$	<input type="checkbox"/>
$P(\mu \leq X)$	<input type="checkbox"/>
$P(X \leq \mu - \sigma)$	<input type="checkbox"/>
$P(\mu - \sigma \leq X \leq \mu + \sigma)$	<input type="checkbox"/>
$P(\mu - 2 \cdot \sigma \leq X)$	<input type="checkbox"/>

[0/1 p.]

Task 1

Numbers and Sets of Numbers

Five statements about numbers and sets of numbers are given.

Task:

Put a cross next to each of the two correct statements.

$\sqrt{\frac{9}{2}}$ is a rational number.	<input type="checkbox"/>
$-\sqrt{100}$ is an integer.	<input type="checkbox"/>
$\sqrt{15}$ has a terminating decimal representation.	<input type="checkbox"/>
$\sqrt{2}$ is a rational number.	<input type="checkbox"/>
-4 is not the square of a real number.	<input type="checkbox"/>

[0/1 point]

Task 2

Prize Distribution

A team consisting of three players wins € 10,000. The prize is divided up as follows: player *B* receives 50 % more than player *A*, player *C* receives 20 % less than player *B*.

The variable x represents the amount of money that player *A* receives (x in €).

Task:

Write down an equation that can be used to calculate x .

[0/1 point]

Task 3

Delegation

A delegation is to be formed from a large group of youths and adults.

The following three rules should apply:

1. The delegation should consist of at least 8 members.
2. The delegation should consist of no more than 12 members.
3. The delegation should consist of at least twice as many youths as adults.

Two of the three rules have been described by inequalities below. The number of youths in the delegation is described by J and the number of adults in the delegation is described by E .

Task:

Put a cross next to each of the two correct inequalities.

$J + E \leq 12$	<input type="checkbox"/>
$J \geq 2 \cdot E$	<input type="checkbox"/>
$J + E \leq 8$	<input type="checkbox"/>
$J - 2 \cdot E < 0$	<input type="checkbox"/>
$E \geq 2 \cdot J$	<input type="checkbox"/>

[0/1 point]

Task 4

Directions on a Compass

The illustration below shows a symmetric wind rose showing the compass points.

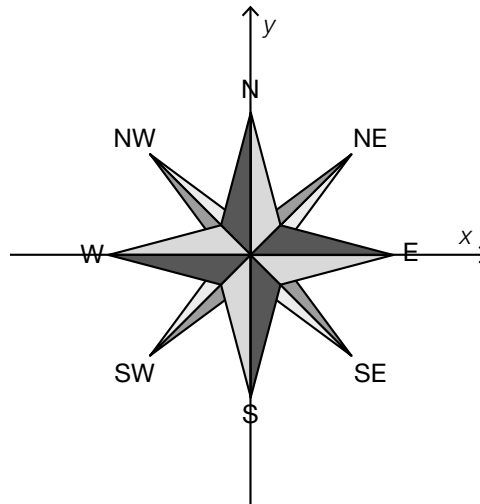

The velocity of a ship travelling in a north-west (NW) direction is described by the vector $\vec{u} = \begin{pmatrix} -a \\ a \end{pmatrix}$ with $a \in \mathbb{R}^+$.

Task:

Write down a vector \vec{v} that describes the velocity of a ship travelling in a north-east (NE) direction.

$\vec{v} =$ _____

[0/1 point]

Task 5

Scaling Coordinate Axes

The following coordinate system with axes in different scales shows a straight line g . a has been marked on the x -axis and b has been marked on the y -axis. Both a and b are integers.

The line g is described by $y = -2 \cdot x + 4$.

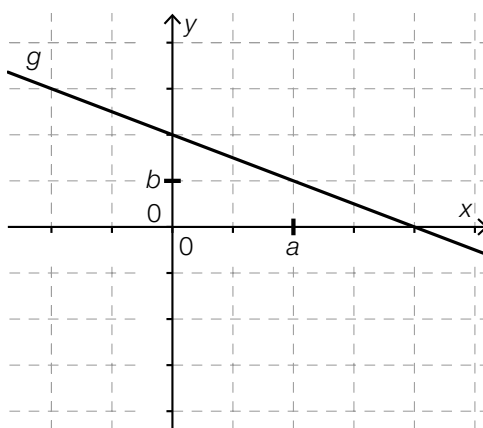

Task:

Determine a and b .

$a =$ _____

$b =$ _____

[0/½/1 point]

Task 6

Train Track

The slope of a straight train track is measured in per mille (‰). For example an altitude change of 1 m per 1 000 m distance travelled horizontally translates to a slope of 1 ‰.

Task:

Write down an equation with which one can exactly calculate the angle of the slope α ($\alpha > 0$) of a straight train track with a slope of 30 ‰.

[0/1 point]

Task 7

Cost Function

The total costs that accumulate while producing a product can be modelled using the differentiable cost function K . In this function, K assigns the cost $K(x)$ (x in quantity units (QU), $K(x)$ in monetary units (MU)) to the production volume x .

The following conditions apply for the cost function $K: [0, x_2] \rightarrow \mathbb{R}$ and x_1 with $0 < x_1 < x_2$:

- K is strictly monotonically increasing in the interval $[0, x_2]$.
- The fixed costs are 10 MU.
- The cost function is digressive in the interval $[0, x_1)$, which means the costs rise more slowly as the production volume increases.
- The point of cost reversal lies at a production volume of x_1 . The point of cost reversal of K is the point from which the costs rise more and more.

Task:

Sketch the shape of the graph of one such cost function K into the coordinate system below.

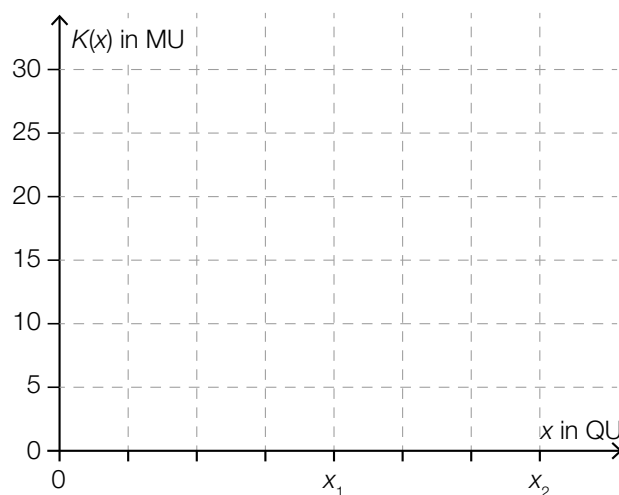

[0/1 point]

Task 8

Train

A train moves forward at a constant speed until the time $t = 0$. After the time $t = 0$, the train increases its speed.

The function v assigns the point in time t with $0 \leq t \leq 60$ to the speed $v(t) = a \cdot t + b$ (t in s, $v(t)$ in m/s, $a, b \in \mathbb{R}$).

Task:

Complete the following sentence by putting a cross next to one of the given possibilities for each gap so that the sentence becomes a correct statement.

For parameter a _____ ① _____ holds and for parameter b _____ ② _____ holds.

①	
$a < 0$	<input type="checkbox"/>
$a = 0$	<input type="checkbox"/>
$a > 0$	<input type="checkbox"/>

②	
$b < 0$	<input type="checkbox"/>
$b = 0$	<input type="checkbox"/>
$b > 0$	<input type="checkbox"/>

[0/½/1 point]

Task 9

Linear Function

A linear function $f: \mathbb{R} \rightarrow \mathbb{R}$ with $f(x) = k \cdot x + d$ with $k, d \in \mathbb{R}$ and $k \neq 0$ is given.

$$\frac{f(5) - f(a)}{2} = k \text{ for } a \in \mathbb{R} \text{ holds.}$$

Task:

Determine a .

$a =$ _____

[0/1 point]

Task 10

Grape Harvest

The grape harvest in a vineyard progresses faster the more people are involved. The function f models the indirectly proportional relationship between the time needed to harvest the grapes and the number of people involved. $f(n)$ describes the time needed to harvest the grapes when n people are involved ($n \in \mathbb{N} \setminus \{0\}$, $f(n)$ in hours).

Task:

Write down $f(n)$, if it is known that the time needed to harvest the grapes when 8 people are working is 6 hours.

$f(n) =$ _____ with $n \in \mathbb{N} \setminus \{0\}$

[0/1 point]

Task 11

Number of Animals

It can be assumed that the number of animals of a specific species of animals on earth increases by 1.8 % each year.

Task:

Determine the time period in years that it takes for the number of animals of this species to double on earth.

Duration: approximately _____ years

[0/1 point]

Task 12

Movement on a Circle

A point P moves counter-clockwise along a circle with centre $M = (0,0)$ at constant speed. At the beginning of the motion (at time $t = 0$), the point P lies on the positive x -axis, as shown in the following illustration.

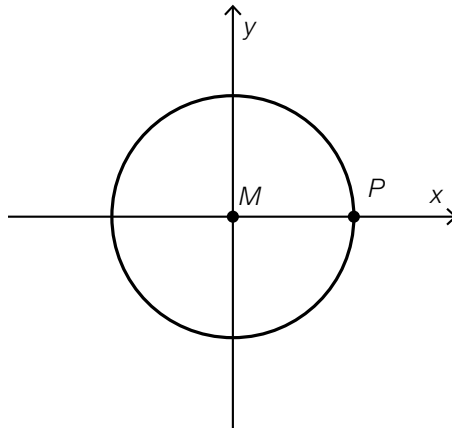

The function f assigns the time t to the second coordinate $f(t) = a \cdot \sin(b \cdot t)$ of the point P at the time t (t in s, $f(t)$ in dm, $a, b \in \mathbb{R}^+$). The following illustration shows the graph of f , which goes through the point H , whereby $f'(1.5) = 0$ holds.

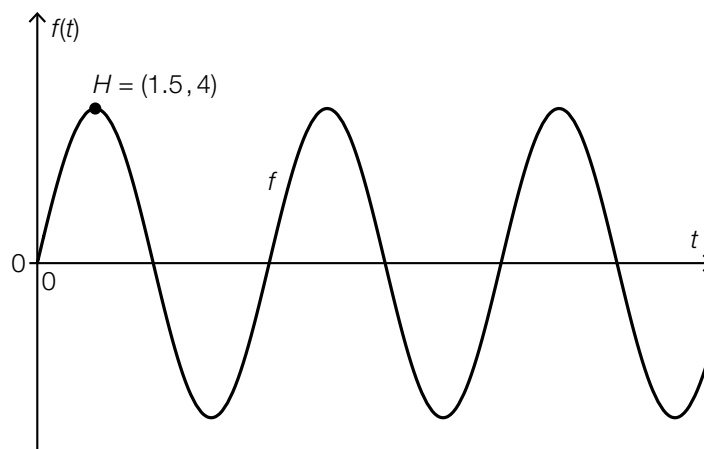

Task:

Determine the radius of the circle and the period of the point P (the time required for one revolution).

Radius of the circle: _____ dm

Period: _____ s

[0/1/2/1 point]

Task 13

Absolute and Relative Change of a Function

The absolute change of a function $f: \mathbb{R} \rightarrow \mathbb{R}$ in an interval $[a, b]$, is described by A . The relative change of f in an interval $[a, b]$ is described by R , whereby $f(a) \neq 0$ and $a < b$ hold.

Task:

Write down an equation that shows the relationship between A and R .

[0/1 point]

Task 14

Price of Oil

The following diagram shows the price trend for crude oil in the period from 8.6.2012 until 8.9.2012.

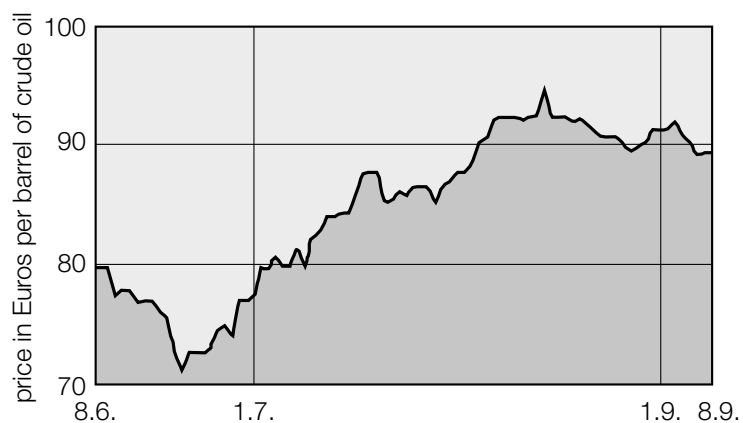

Source: <http://www.heizoel24.at/charts/rohoel> [14.12.2012] (adapted).

Task:

Determine the average rate of change of the price per barrel of crude oil per month during the period from 1.7.2012 until 1.9.2012.

average rate of change: _____ Euros per barrel of crude oil per month

[0/1 point]

Task 15

Population

The number of deer in a forest at the end of the year i ($i = 1, 2, 3$) is described by R_i . By the end of the first year, there are 60 deer in this forest.

The following equation describes the development of the population of the deer.

$$R_{i+1} = 1.2 \cdot R_i - 2 \text{ for } i = 1, 2$$

Task:

Determine the number of deer in this forest at the end of the third year.

The number of deer at the end of the third year is _____.

[0/1 point]

Task 16

Growth of a Plant

At the beginning of a three week long observation process, a certain plant is 15 cm tall. The instantaneous rate of change of the height of this plant is modelled by the function v in terms of the time t .

The following holds:

$$v(t) = 3 - 0.3 \cdot t^2 \text{ with } t \in [0, 3] \text{ in weeks and } v(t) \text{ in cm/week}$$

The function h assigns each time $t \in [0, 3]$ to the height $h(t)$ of the plant (t in weeks, $h(t)$ in cm).

Task:

Write down $h(t)$.

$$h(t) = \underline{\hspace{15em}}$$

[0/1 point]

Task 17

Graphs of Curves

The four graphs given below on the left each show a tangent t to a polynomial function f at a point $P = (x_p, f(x_p))$. The point P is the only common point between the graph of f and the tangent t . In the table given below on the right, there are six statements about $f'(x_p)$ and $f''(x_p)$.

Task:

Match each of the four graphs to the corresponding statement (from A to F).

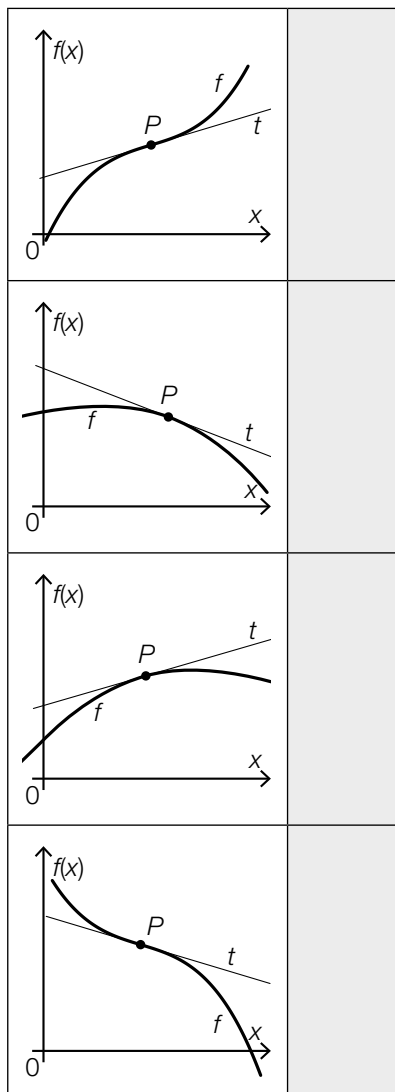

A	$f'(x_p) > 0$ and $f''(x_p) > 0$
B	$f'(x_p) > 0$ and $f''(x_p) < 0$
C	$f'(x_p) < 0$ and $f''(x_p) > 0$
D	$f'(x_p) < 0$ and $f''(x_p) < 0$
E	$f'(x_p) > 0$ and $f''(x_p) = 0$
F	$f'(x_p) < 0$ and $f''(x_p) = 0$

[0/1/2/1 point]

Task 18

Comparison of Definite Integrals

Five graphs of polynomial functions are illustrated below.

Task:

Put a cross next to the two graphs for which $\int_{-5}^{-1} f(x) dx > \int_{-5}^{+1} f(x) dx$ holds.

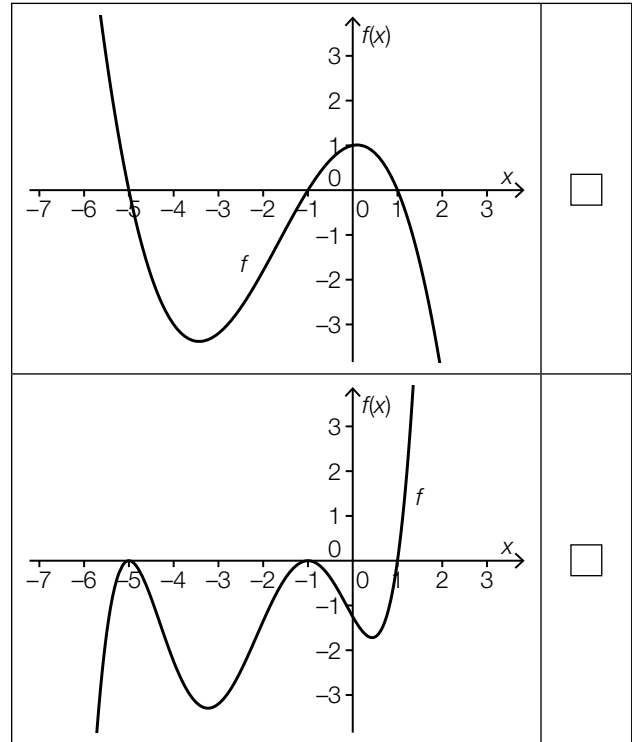
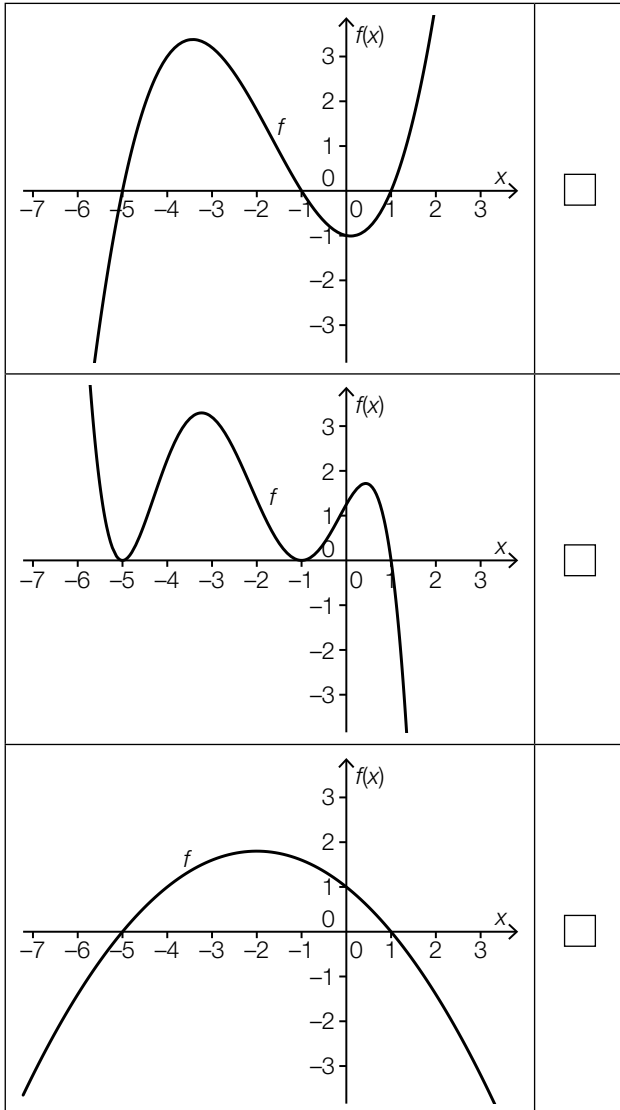

[0/1 point]

Task 19

GDP 2018

The gross domestic product (GDP) of Austria in the year 2018 amounted to 385.71 billion Euros.

Source: <https://de.statista.com/statistik/daten/studie/14390/umfrage/bruttoinlandsprodukt-in-oesterreich/> [21.11.2019].

If the revenue generated from exports exceeds the expenditures from imports then there is an account surplus. Otherwise there is an account deficit. The following illustration shows the account surpluses and deficits, respectively, for certain countries as account balances given as a percentage of each GDP for the year 2018.

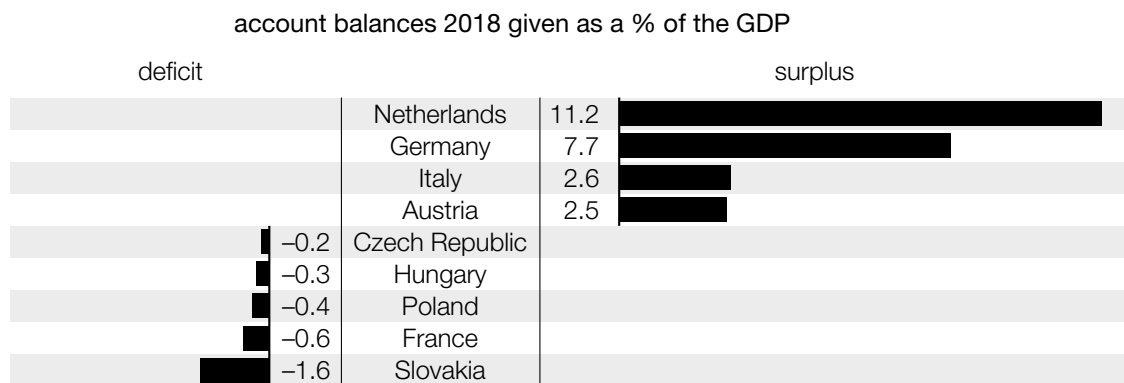

Source: <https://www.oenb.at/isaweb/report.do?report=10.18> [21.11.2019].

Task:

Calculate the account surplus (in billions of Euros) for Austria in the year 2018.

account surplus: _____ billion Euros

[0/1 point]

Task 20

List of Numbers

A list of numbers $x_1, x_2, x_3, \dots, x_{40}$, for which $x_1 < x_2 < \dots < x_{40}$ holds, is given.

Task:

Put a cross next to the number that can be added to the list of numbers above so that the median of the given list does not change.

$\frac{x_1 + x_{20}}{2}$	<input type="checkbox"/>
$\frac{x_1 + x_{40}}{2}$	<input type="checkbox"/>
$\frac{x_{20} + x_{21}}{2}$	<input type="checkbox"/>
$\frac{x_{20} + x_{40}}{2}$	<input type="checkbox"/>
x_{20}	<input type="checkbox"/>
x_{21}	<input type="checkbox"/>

[0/1 point]

Task 21

Favourite Subject

All children attending the first or second grade of a school were asked what their favourite subject was. Each child was allowed to choose exactly one subject. The following table shows the gathered data.

	favourite subject math	other favourite subject
first graders	47	241
second graders	33	287
total	80	528

A child attending the first grade is randomly selected. (The probability of selecting any child from the first grade is the same for all first graders.)

Task:

Calculate the probability that this child chose math as his or her favourite subject.

[0/1 point]

Task 22

Probability Distribution

An urn holds only white and black balls. Three balls are selected without replacement. The random variable X describes the number of white balls drawn from the urn.

The following table shows the probability distribution of the random variable X .

x	1	2	3
$P(X = x)$	0.3	0.6	0.1

Task:

Put a cross next to each of the two correct statements.

The probability of selecting no more than two white balls is 0.9.	<input type="checkbox"/>
The probability of selecting at least one white ball is 0.3.	<input type="checkbox"/>
The probability of selecting more than one white ball is 0.6.	<input type="checkbox"/>
The probability of selecting exactly two black balls and one white ball is 0.1.	<input type="checkbox"/>
The probability of selecting at least one black ball is 0.9.	<input type="checkbox"/>

[0/1 point]

Task 23

Room Booking

A hotel manager assumes, due to years of experience, that every room booking made independently from another room booking is cancelled with a probability of 10 %. For a specific date, he accepts 40 independent room bookings.

Task:

Calculate the probability that no more than 5 % of the 40 room bookings on that specific date are cancelled.

[0/1 point]

Task 24

Conditioning Experiment

During a conditioning experiment, German shepherds learn to operate a mechanism to receive feed. After a training phase in which 50 German shepherds participate, 40 of them can operate the mechanism.

The relative proportion of these German shepherds that can operate the mechanism after the training phase is described by h .

Out of this data, a confidence interval $[a, 0.91]$ symmetrical to h with $a \in \mathbb{R}$ for the unknown proportion p of all German shepherds that can operate the mechanism after such a training phase is determined.

Task:

Determine the lower boundary a of the confidence interval.

[0/1 point]

Task 1

Calculation Operations

Let a and b be two natural numbers for which $b \neq 0$ holds.

Task:

Put a cross next to each of the two expressions that always result in a natural number.

$a + b$	<input type="checkbox"/>
$a - b$	<input type="checkbox"/>
$\frac{a}{b}$	<input type="checkbox"/>
$a \cdot b$	<input type="checkbox"/>
$\sqrt[a]{b}$	<input type="checkbox"/>

[0/1 point]

Task 2

Active Ingredient

A particular medication is consumed in liquid form. Per millilitre of liquid, there are 30 milligrams of the active ingredient. Martin consumes 85 millilitres of this medication. 10 % of the active ingredient reaches his bloodstream.

Task:

Write down how many milligrams of this active ingredient reach Martin's bloodstream.

_____ milligrams of the active ingredient reach Martin's bloodstream.

[0/1 point]

Task 3

Movement of a Body

A body moves in a straight line with a constant velocity of 8 m/s and covers 100 m.

Task:

Interpret the solution to the equation $8 \cdot x - 100 = 0$ in the given context.

[0/1 point]

Task 4

Vectors

The diagram below shows four points P , Q , R and S as well as two vectors \vec{u} and \vec{v} .

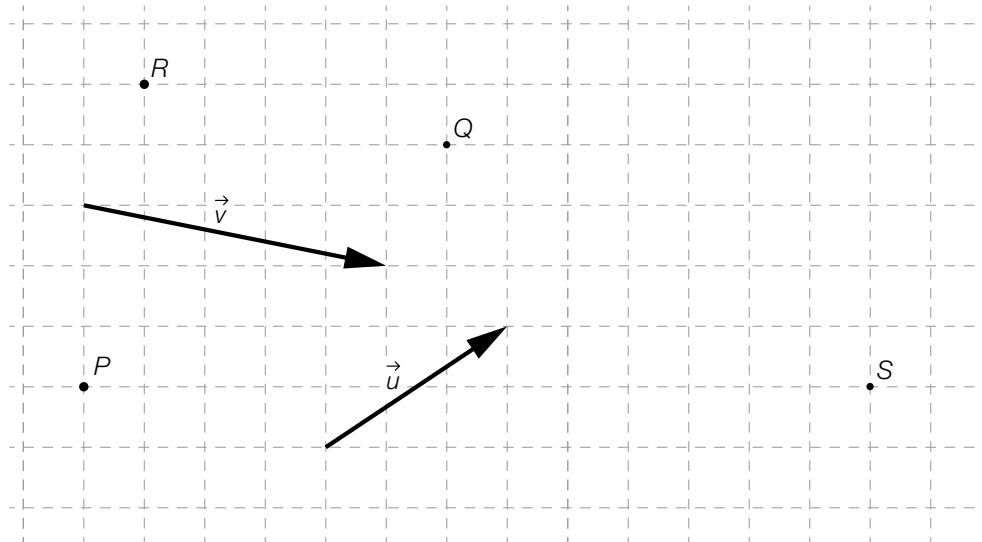

Task:

Match each of the four vectors to the corresponding expression (from A to F).

\vec{PQ}	
\vec{PR}	
\vec{QR}	
\vec{PS}	

A	$2 \cdot \vec{u} - \vec{v}$
B	$2 \cdot \vec{v} - \vec{u}$
C	$-\vec{v}$
D	$2 \cdot \vec{v} + \vec{u}$
E	$2 \cdot \vec{u}$
F	$2 \cdot \vec{u} + 2 \cdot \vec{v}$

[0/½/1 point]

Task 5

Lines in \mathbb{R}^2

For two lines g and h in \mathbb{R}^2 , the following statements hold:

- The line g with direction vector \vec{g} has the normal vector \vec{n}_g .
- The line h with direction vector \vec{h} has the normal vector \vec{n}_h .
- The lines g and h are perpendicular to each other.

Task:

Put a cross next to each of the two statements that are always true.

$\vec{n}_g \cdot \vec{h} = 0$	<input type="checkbox"/>
$\vec{n}_g \cdot \vec{n}_h = 0$	<input type="checkbox"/>
$\vec{g} = r \cdot \vec{h}$ with $r \in \mathbb{R} \setminus \{0\}$	<input type="checkbox"/>
$\vec{g} = r \cdot \vec{n}_h$ with $r \in \mathbb{R} \setminus \{0\}$	<input type="checkbox"/>
$\vec{g} \cdot \vec{n}_h = 0$	<input type="checkbox"/>

[0/1 point]

Task 6

Ladder

A 4 m long straight ladder is placed on a horizontal surface and is leaned against the vertical wall of a house.

The ladder must make an angle of between 65° and 75° with the floor in order to avoid either toppling over or slipping.

Task:

Determine the minimum distance and the maximum distance between the lower end of the ladder and the wall of the house.

minimum distance from the wall of the house: _____ m

maximum distance from the wall of the house: _____ m

[0/½/1 point]

Task 7

Graph of a Polynomial Function

A polynomial function $f: [-3, 3] \rightarrow \mathbb{R}, x \mapsto f(x)$ has the following properties:

- The graph of f is symmetrical about the vertical axis.
- The function f has a local minimum at the point $(2, 1)$.
- The graph of f crosses the vertical axis at the point $(0, 3)$.

Task:

Sketch the graph of one such function f in the coordinate system shown below over the interval $[-3, 3]$.

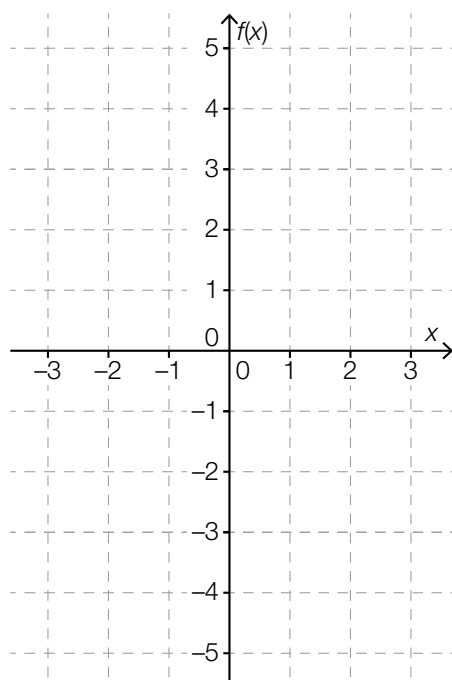

[0/1 point]

Task 8

Feed Requirement

Horses are kept in a stable for t days. The daily feed requirement for each of these horses is assumed to be constant and is represented by c .

The function f describes the total feed requirement $f(p)$ for t days in terms of the number p of horses in this stable.

Task:

Put a cross next to the correct equation.

$f(p) = p + t + c$	<input type="checkbox"/>
$f(p) = c + p \cdot t$	<input type="checkbox"/>
$f(p) = c \cdot \frac{t}{p}$	<input type="checkbox"/>
$f(p) = \frac{c}{p \cdot t}$	<input type="checkbox"/>
$f(p) = c \cdot p \cdot t$	<input type="checkbox"/>
$f(p) = \frac{p \cdot t}{c}$	<input type="checkbox"/>

[0/1 point]

Task 9

Power Function

Let $f: \mathbb{R} \setminus \{0\} \rightarrow \mathbb{R}$ with $f(x) = \frac{a}{x^2}$ with $a \in \mathbb{R} \setminus \{0\}$ be a power function.

Task:

Put a cross next to each of the two statements that are always true about the function f .

$f\left(\frac{1}{a}\right) = 1$	<input type="checkbox"/>
$f(x + 1) = \frac{a}{x^2 - 2 \cdot x + 1}$	<input type="checkbox"/>
$f(2 \cdot x) = \frac{a}{4 \cdot x^2}$	<input type="checkbox"/>
$f(2 \cdot a) = \frac{1}{2 \cdot a}$	<input type="checkbox"/>
$f(-x) = f(x)$	<input type="checkbox"/>

[0/1 point]

Task 10

Pressure and Volume of an Ideal Gas

When the temperature remains constant, the pressure and the volume of an ideal gas are indirectly proportional to each other. The function p assigns the pressure $p(V)$ to the volume V (V in m^3 , $p(V)$ in pascals).

Task:

Write down $p(V)$ where $V \in \mathbb{R}^+$ if the volume is 4 m^3 at a pressure of $50\,000$ pascals.

$p(V) =$ _____

[0/1 point]

Task 11

Half-Life

The function f with $f(t) = 80 \cdot b^t$ with $b \in \mathbb{R}^+$ describes the mass $f(t)$ of a radioactive substance in terms of the time t (t in h, $f(t)$ in mg). The half-life of the radioactive substance is 4 h. The substance is observed from time $t = 0$.

Task:

Determine the mass (in mg) of the radioactive substance that remains after the first 3 half-lives.

[0/1 point]

Task 12

Alternating Current

For sinusoidal alternating current, the value of the current changes periodically.

The diagram below shows the current $I(t)$ in terms of the time t for a sinusoidal alternating current (t in s, $I(t)$ in A).

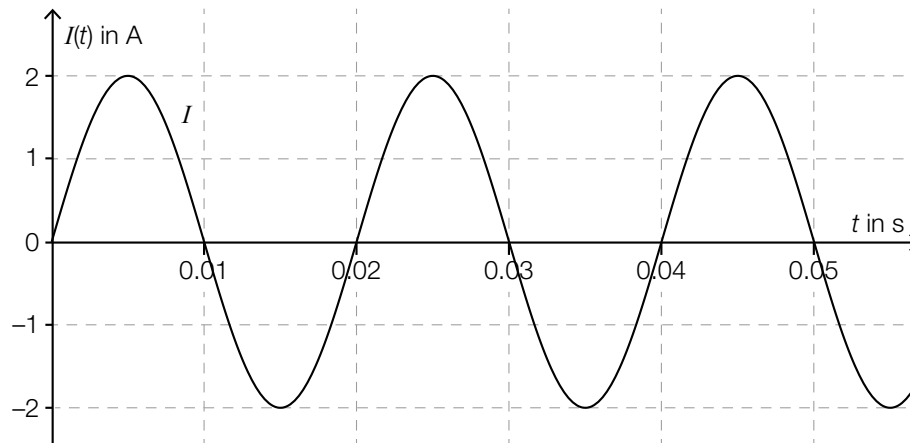

Task:

Write down the maximum value of the current and the length of one period.

maximum value: _____ A

length of one period: _____ s

[0/½/1 point]

Task 13

Difference Quotient and Differential Quotient

The diagram below shows the graph of a third degree polynomial function f .

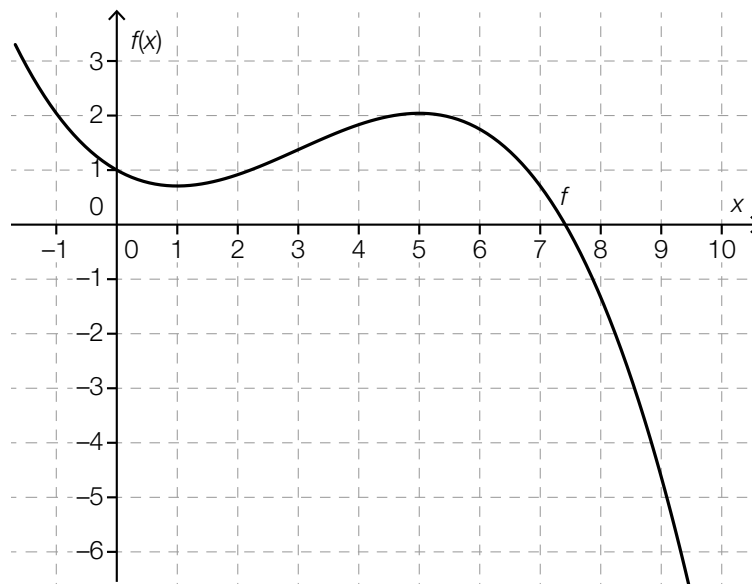

Task:

Put a cross next to each of the two correct statements.

In the interval $(0, 2)$, there is a point a such that the following holds: $\frac{f(a) - f(0)}{a - 0} = f'(0)$	<input type="checkbox"/>
In the interval $(4, 6)$, there is a point a such that the following holds: $\frac{f(a) - f(0)}{a - 0} = f'(0)$	<input type="checkbox"/>
For all $a \in (0, 1)$ the following statement holds: The smaller a is, the less $\frac{f(a) - f(0)}{a - 0}$ differs from $f'(0)$.	<input type="checkbox"/>
For all $a \in (2, 5)$ the following statement holds: The larger a is, the less $\frac{f(a) - f(0)}{a - 0}$ differs from $f'(0)$.	<input type="checkbox"/>
For all $a \in (2, 3)$ the following holds: $\frac{f(a) - f(0)}{a - 0} > f'(0)$	<input type="checkbox"/>

[0/1 point]

Task 14

Rates of Change

The diagram below shows the graph of a function f over the interval $[1, 7]$.

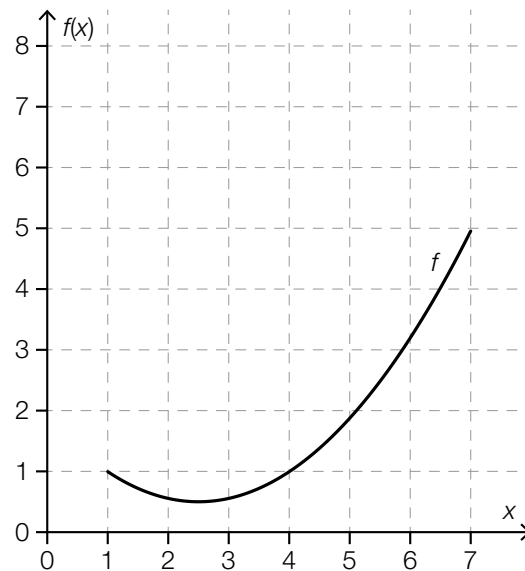

Task:

On the diagram above, draw the point P on the graph of f for which the differential quotient of the function f corresponds to the difference quotient over the interval $[1, 7]$.

[0/1 point]

Task 15

Bacterial Culture

The number of bacteria in a bacterial culture in terms of the time t is investigated. The number of bacteria in this bacterial culture increases each minute by the same percentage.

In the equations shown below, $N(t)$ is the number of bacteria in this bacterial culture at time t (in minutes) and $k \in (0, 1)$ is a real number.

Task:

Put a cross next to each of the two correct equations.

$N(t + 1) - N(t) = -k \cdot N(t)$	<input type="checkbox"/>
$N(t + 1) - N(t) = k$	<input type="checkbox"/>
$N(t + 1) - N(t) = k \cdot N(t)$	<input type="checkbox"/>
$N(t + 1) = k \cdot N(t)$	<input type="checkbox"/>
$N(t + 1) = N(t) \cdot (1 + k)$	<input type="checkbox"/>

[0/1 point]

Task 16

Antiderivative

Let $f: \mathbb{R} \rightarrow \mathbb{R}$, $x \mapsto f(x)$ be a function.

The function $g: \mathbb{R} \rightarrow \mathbb{R}$, $x \mapsto g(x)$ is an antiderivative of f .

For a function $h: \mathbb{R} \rightarrow \mathbb{R}$, $x \mapsto h(x)$ and $c \in \mathbb{R} \setminus \{0\}$ the statement $h(x) = g(x) + c$ holds.

Task:

Write down whether h is also an antiderivative of f and justify your answer.

[0/1 point]

Task 17

Polynomial Function

The diagram below shows the graph of a fourth degree polynomial function $f: x \mapsto f(x)$. The x -axis has not been included in the diagram.

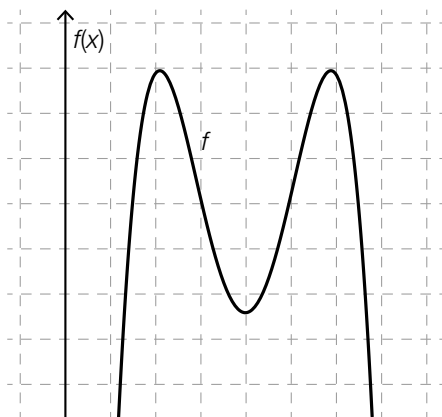

Task:

Put a cross next to each of the two statements that are true for the polynomial function f shown above regardless of the position of the x -axis.

There are exactly two x -values x_1 and x_2 for which $f(x_1) = 0$ and $f(x_2) = 0$.	<input type="checkbox"/>
There are exactly two x -values x_1 and x_2 for which $f'(x_1) = 0$ and $f'(x_2) = 0$.	<input type="checkbox"/>
There is exactly one x -value x_1 for which $f''(x_1) = 0$.	<input type="checkbox"/>
There is exactly one x -value x_1 for which $f'(x_1) = 0$ and $f''(x_1) > 0$.	<input type="checkbox"/>
There is exactly one x -value x_1 for which $f'(x_1) > 0$ and $f''(x_1) = 0$.	<input type="checkbox"/>

[0/1 point]

Task 18

Velocity Function

The function v with $v(t) = 0.5 \cdot t + 2$ assigns each point in time t to the velocity $v(t)$ of a body (t in s, $v(t)$ in m/s).

The following calculation is carried out:

$$\int_1^5 (0.5 \cdot t + 2) dt = 14$$

Task:

With regard to the movement of the body, write down a question that can be answered with the calculation shown above.

[0/1 point]

Task 19

Boxplots of Heights

The boxplots below show the distributions of the heights of the pupils in two classes (4A and 4B). There is the same number of pupils in both classes.

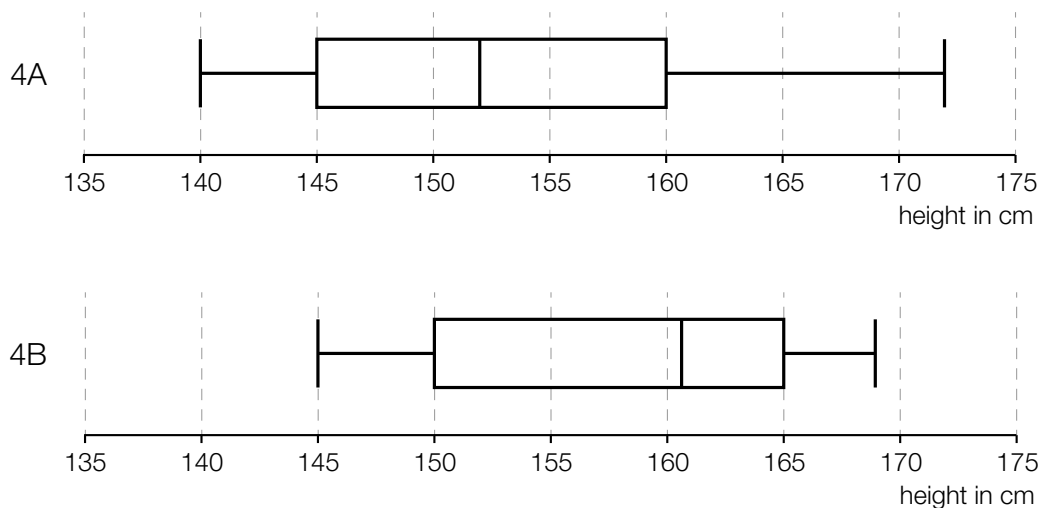

Task:

Put a cross next to each of the two statements that are definitely true.

In 4A, more than half of the pupils are shorter than 150 cm.	<input type="checkbox"/>
In 4B, more pupils are taller than 160 cm than in 4A.	<input type="checkbox"/>
The range of the heights in 4A is larger than in 4B.	<input type="checkbox"/>
The tallest pupil across both classes is in 4B.	<input type="checkbox"/>
In 4A, the most common height is 160 cm.	<input type="checkbox"/>

[0/1 point]

Task 20

Estimate of a Probability

A dice with faces that show the numbers 1, 2, 3, 4, 5, and 6 has one corner that is damaged. Therefore, it is assumed that the probability of rolling a particular number is not the same for every number.

A person conducted two separate series of throws in which they rolled the dice 50 times each. The absolute frequencies of the numbers that were rolled were recorded. The table below shows these recordings.

number shown on the dice	1	2	3	4	5	6
frequency in series 1	7	8	7	10	8	10
frequency in series 2	6	9	7	9	10	9

Task:

Based on the results of both series of throws, write down an estimate for the probability p (as a %) of rolling a 6 with this dice.

$p =$ _____ %

[0/1 point]

Task 21

Test Tasks

For an international comparative study, a large number of test tasks have been created. Experience has shown that 20 % of the tasks are discarded during a preliminary evaluation process due to the design of the tasks. The rest of the tasks undergo a second evaluation process. Experience has shown that 10 % of these tasks are discarded during this process due to the task content.

Task:

Determine the probability that a task will be discarded.

[0/1 point]

Task 22

Binomial Coefficient

A group contains 12 school pupils.

Task:

Complete the gaps in the following sentence by putting a cross next to one of the given possibilities for each gap so that the sentence becomes a correct statement.

The binomial coefficient $\binom{12}{2}$ has the value $\text{\textcircled{1}}$; it can be used to determine the number of different possibilities of $\text{\textcircled{2}}$.

\text{\textcircled{1}}	
24	<input type="checkbox"/>
66	<input type="checkbox"/>
144	<input type="checkbox"/>

\text{\textcircled{2}}	
selecting 2 pupils from this group who should hold a presentation together	<input type="checkbox"/>
awarding 2 pupils from this group 2 different prizes	<input type="checkbox"/>
dividing the pupils into 2 groups of 6 pupils each	<input type="checkbox"/>

[0/1/2/1 point]

Task 23

Tossing a Coin

After being tossed, a coin shows either *heads* or *tails*. For each toss, the probability of the coin showing *heads* is exactly the same as the probability of the coin showing *tails*. The results of the tosses are independent of each other. The coin is tossed 20 times.

Task:

Determine the probability that the coin shows *heads* exactly 12 times during these 20 tosses.

[0/1 point]

Task 24

Confidence Interval

Based on the relative sample frequency h from a representative survey of 500 people, the 95 % confidence interval $[h - 0.04, h + 0.04]$ for the unknown relative proportion of the supporters of a bypass is determined.

A second representative survey of 2000 people gives the same relative sample frequency h .

Task:

For this second survey, write down the 95 % confidence interval that is symmetrical about h for the unknown relative proportion of the supporters of the bypass.

[0/1 point]

Task 1

Translating a Triangle

The diagram below shows a triangle with vertices A , B and C as well as the point A_1 . The points shown in bold have integer coordinates.

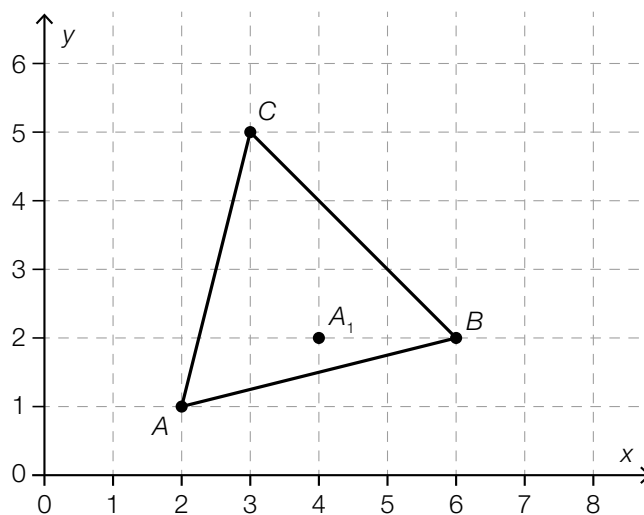

The triangle is to be translated by the vector $\overrightarrow{AA_1}$ so that the points A , B and C become the points A_1 , B_1 and C_1 .

Task:

Determine the coordinates of the point C_1 .

$C_1 = (\quad | \quad)$

[0/1/2/1 point]

Task 2

Solution to an Equation

An equation in $x \in \mathbb{R}$ is shown below.

$$\sqrt{2 \cdot x - 6} = a \text{ with } a \in \mathbb{R}_0^+$$

Task:

Put a cross next to the interval that contains the solution to the equation given above for all values of $a \in \mathbb{R}_0^+$.

$(-\infty, -3]$	<input type="checkbox"/>
$[3, \infty)$	<input type="checkbox"/>
$[-3, 0)$	<input type="checkbox"/>
$[0, 3)$	<input type="checkbox"/>
$[-6, -3)$	<input type="checkbox"/>
$[3, 6]$	<input type="checkbox"/>

[0/1 point]

Task 3

Cyclists

Alexander's school and Bernhard's school are connected by a 13 km long straight road.

On a particular day, both boys cycle along this road from their respective schools towards each other. They set off at different times and meet each other t hours after Alexander's departure.

Up to the time they meet each other, the following statements hold:

- Alexander cycles at an average speed of 18 km/h.
- Bernhard cycles at an average speed of 24 km/h.

For the context described above, the equation below is formed and solved.

$$18 \cdot t + 24 \cdot \left(t - \frac{1}{3}\right) = 13$$

$$t = \frac{1}{2}$$

Task:

Put a cross next to each of the two statements that are true with respect to the equation given above and its solution.

Alexander sets off 10 minutes later than Bernhard.	<input type="checkbox"/>
When they meet, Alexander has been travelling for 30 minutes.	<input type="checkbox"/>
When they meet, Bernhard has been travelling for 20 minutes.	<input type="checkbox"/>
When they meet, Alexander has covered a distance of 9 km.	<input type="checkbox"/>
When they meet, the boys are further away from Bernhard's school than from Alexander's school.	<input type="checkbox"/>

[0/1 point]

Task 4

Quadratic Equation

For $a \in \mathbb{R} \setminus \{0\}$, let $(a \cdot x + 7)^2 = 25$ be a quadratic equation in $x \in \mathbb{R}$.

Task:

Write down all $a \in \mathbb{R} \setminus \{0\}$ for which $x = -4$ is a solution to the quadratic equation shown above.

[0/1 point]

Task 5

Vector Equation of a Line

Let g be a line with vector equation $g: X = A + t \cdot \overrightarrow{AB}$ with $t \in \mathbb{R}$.

Task:

Determine the value of t such that $X = B$ holds.

[0/1 point]

Task 6

Ladder

A ladder is leaning against a vertical wall.

The top of the ladder is at a height of 6 m on the wall, and it makes an angle of 20° with the wall. This situation is depicted in the diagram shown (diagram not to scale).

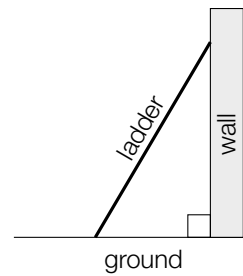

Task:

Determine the length of the ladder.

[0/1 point]

Task 7

Latitude

The shape of the Earth is approximately a sphere with a radius of 6370 km.

The diagram below shows the northern hemisphere of the Earth shaded in grey. In the northern hemisphere, the latitude φ is measured from the equator in a northerly direction, where $0^\circ \leq \varphi \leq 90^\circ$.

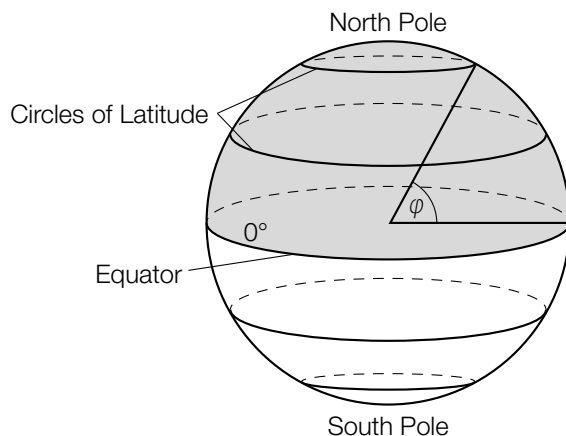

To determine the radius r (in km) of a circle of latitude (at the latitude φ), the following formula holds:

$$r = 6370 \cdot \cos(\varphi)$$

Task:

Write down the smallest possible interval W that contains all values of r .

$$W = [\quad , \quad]$$

[0/1 point]

Task 8

Properties of Functions

Four equations of the real functions f_1 to f_4 (with $a, b \in \mathbb{R}^+$ and $b < 1$) and six lists of properties of functions are shown below.

Task:

Match each of the four equations of functions to the corresponding list (from A to F).

$f_1(x) = a \cdot b^x$	
$f_2(x) = a \cdot x + b$	
$f_3(x) = a \cdot \sin(b \cdot x)$	
$f_4(x) = a \cdot x^3 + b$	

A	<ul style="list-style-type: none"> – no change in monotonicity – constant gradient – no change in concavity
B	<ul style="list-style-type: none"> – exactly one local maximum or minimum x_0 – symmetrical about the line $x = x_0$ – at most two zeros
C	<ul style="list-style-type: none"> – infinitely many local maxima and minima – infinitely many points of inflexion – no asymptote
D	<ul style="list-style-type: none"> – only defined for $x \in [0, \infty)$ – concave down over its whole domain – no local maxima, local minima or points of inflexion
E	<ul style="list-style-type: none"> – no local maximum or minimum – exactly one zero – exactly one point of inflexion
F	<ul style="list-style-type: none"> – no change in monotonicity – the x-axis is an asymptote – no change in concavity

[0/1/2/1 point]

Task 9

Behaviour of the Graph of a Linear Function

Let f be a linear function with $f(x) = m \cdot x + c$ with $m, c \in \mathbb{R}$ and $c \neq 0$.

The plane is split into four quadrants by the two coordinate axes (see diagram below).

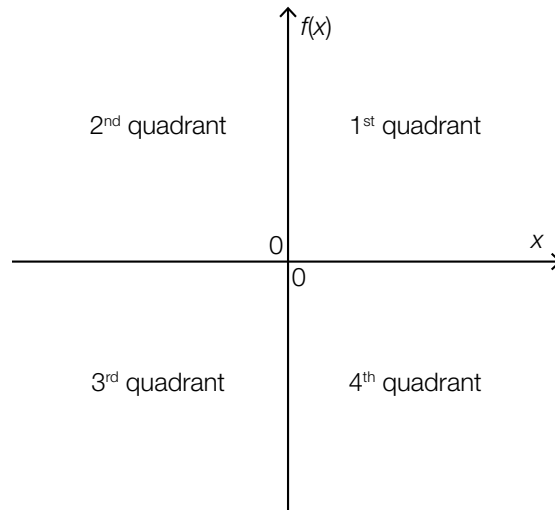

For the graph of f , the following statements hold:

- The graph does not go through the 1st quadrant.
- The graph goes through the 2nd, 3rd and 4th quadrants.

Therefore, certain conditions on m and c must hold.

Task:

Put a cross next to the statement with the correct conditions.

$m < 0$ and $c < 0$	<input type="checkbox"/>
$m < 0$ and $c > 0$	<input type="checkbox"/>
$m > 0$ and $c < 0$	<input type="checkbox"/>
$m > 0$ and $c > 0$	<input type="checkbox"/>
$m = 0$ and $c < 0$	<input type="checkbox"/>
$m = 0$ and $c > 0$	<input type="checkbox"/>

[0/1 point]

Task 10

Polynomial Function

There is a relationship between the degree of a polynomial function and the number of real zeros, local maxima and minima and points of inflexion of the function.

Task:

Complete the following sentence by putting a cross next to one of the given possibilities for each gap so that the sentence becomes a correct statement.

Every _____ ① _____ polynomial function has _____ ② _____ .

①	
4 th degree	<input type="checkbox"/>
5 th degree	<input type="checkbox"/>
6 th degree	<input type="checkbox"/>

②	
at least two distinct local maxima or minima	<input type="checkbox"/>
at least two distinct zeros	<input type="checkbox"/>
at least one point of inflexion	<input type="checkbox"/>

[0/1 point]

Task 11

Half-Life

The radioactive isotope ^{137}Cs (caesium) has a half-life of around 30 years.

The function f gives the percentage of the initial amount of ^{137}Cs that is still present in terms of the time t (t in years, $f(t)$ in % of the initial amount).

The amount of ^{137}Cs that is present at the time $t = 0$ is termed the *initial amount*.

Task:

In the coordinate system shown below, sketch the graph of f over the time interval $[0, 60]$.

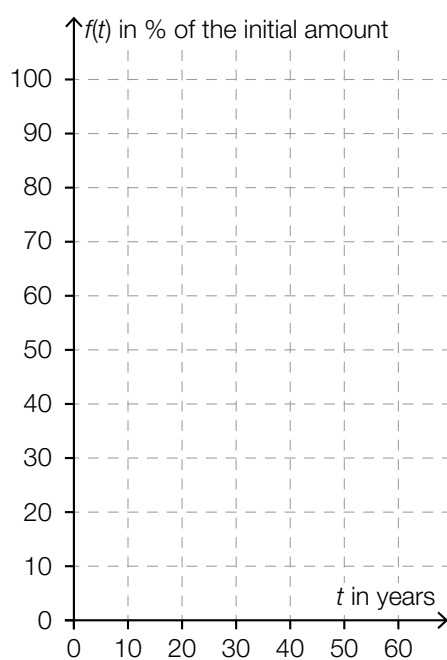

[0/1 point]

Task 12

Trigonometric Function

Let $f: \mathbb{R} \rightarrow \mathbb{R}$ be a function with $f(x) = 3 \cdot \cos(x)$. This function is to be represented in the form $x \mapsto a \cdot \sin(x + b)$, where $a, b \in \mathbb{R}$.

Task:

Write down a correct value for each of a and b .

$a =$ _____

$b =$ _____

[0/½/1 point]

Task 13

Measuring a Velocity

The velocity of a moving body in terms of the time t is modelled by a differentiable function v (t in s, $v(t)$ in m/s). The velocity $v(t)$ is measured starting from the time $t = 0$.

The limit $\lim_{t \rightarrow 3} \frac{v(t) - v(3)}{t - 3}$ is considered.

Task:

Put a cross next to each of the two statements that correctly describe the limit considered above.

The limit gives the instantaneous rate of change of the velocity of the body 3 seconds after the measurements begin.	<input type="checkbox"/>
The limit gives the average speed of the body in the time period $[0, 3]$.	<input type="checkbox"/>
The limit gives the instantaneous acceleration of the body 3 seconds after the measurements begin.	<input type="checkbox"/>
The limit gives the relative change in the velocity of the body in the time period $[0, 3]$.	<input type="checkbox"/>
The limit gives the distance covered by the body in the first 3 seconds.	<input type="checkbox"/>

[0/1 point]

Task 14

Experiment

During an experiment, the temperature of a particular liquid (in °C) was measured at various points in time.

The diagram below shows the results of the measurements 20 min and 30 min after the observation began.

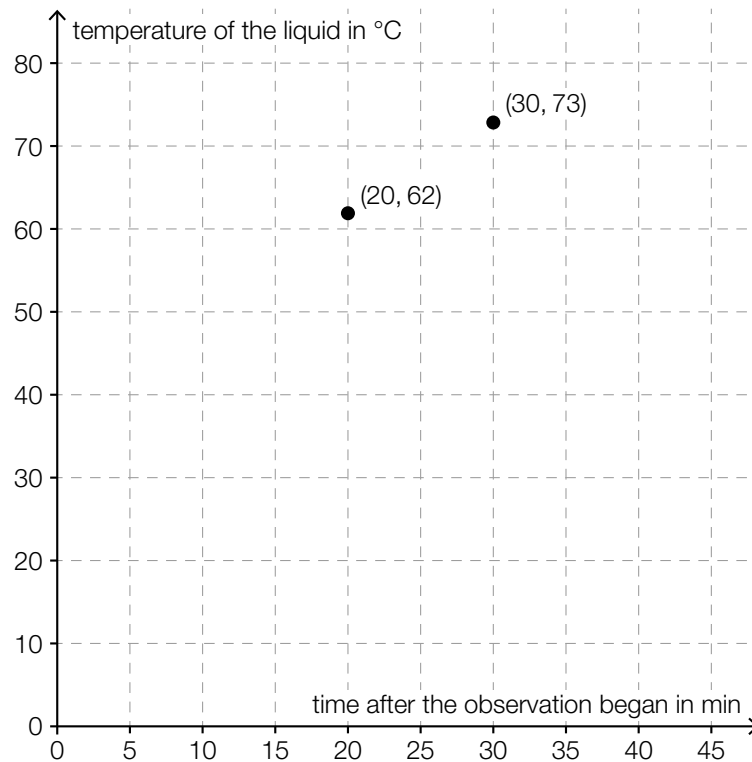

Task:

Determine the average rate of change of the temperature of the liquid in the time interval [20 min, 30 min].

average rate of change: _____ °C/min

[0/1 point]

Task 15

Growth of a Sunflower

The height of a particular sunflower was measured over a number of weeks always at the beginning of each week.

When the measurements began at $t = 0$, the sunflower had a height of $H_0 = 5$ cm. For each point in time t (with $0 \leq t \leq 5$), H_t gives the height of the sunflower.

The table below shows the (rounded) results of the measurements of the height of the sunflower for the first 5 weeks.

time t (in weeks after the measurements began)	height of the sunflower H_t (in cm)
1	36
2	68
3	98
4	128
5	159

Task:

Complete the following sentence by putting a cross next to one of the given possibilities for each gap so that the sentence becomes a correct statement.

The absolute weekly increase in the height of the sunflower is ①; the height of the sunflower H_t can therefore be approximated by a difference equation of the form ②.

①	
always smaller than the increase in the previous week	<input type="checkbox"/>
always greater than the increase in the previous week	<input type="checkbox"/>
roughly constant	<input type="checkbox"/>

②	
$H_{t+1} = H_t \cdot (1 + k)$ with $k \in \mathbb{R}$	<input type="checkbox"/>
$H_{t+1} = H_t + k$ with $k \in \mathbb{R}$	<input type="checkbox"/>
$H_{t+1} = H_t + r \cdot (k - H_t)$ with $k, r \in \mathbb{R}$ and $0 < r < 1$	<input type="checkbox"/>

[0/1/2/1 point]

Task 16

Antiderivatives

Let F be an antiderivative of a polynomial function $f: \mathbb{R} \rightarrow \mathbb{R}$.

Task:

Two of the functions G_1 to G_5 shown below are also antiderivatives of f for all $c \in \mathbb{R} \setminus \{0\}$. Put a cross next to each of the two correct functions.

$G_1 = c \cdot F$	<input type="checkbox"/>
$G_2 = c + F$	<input type="checkbox"/>
$G_3 = F - c$	<input type="checkbox"/>
$G_4 = c - F$	<input type="checkbox"/>
$G_5 = \frac{F}{c}$	<input type="checkbox"/>

[0/1 point]

Task 17

Area between a Graph and the x -Axis

Let $f: [0, 15] \rightarrow \mathbb{R}^+$ be a power function.

The area A of the region that is bounded by the graph of f , the x -axis and the two lines $x = 0$ and $x = 15$ can be approximated by the expression U shown below.

$$U = 5 \cdot (f(0) + f(5) + f(10))$$

The diagram below shows the graph of f and the shaded region whose area can be calculated with the expression U .

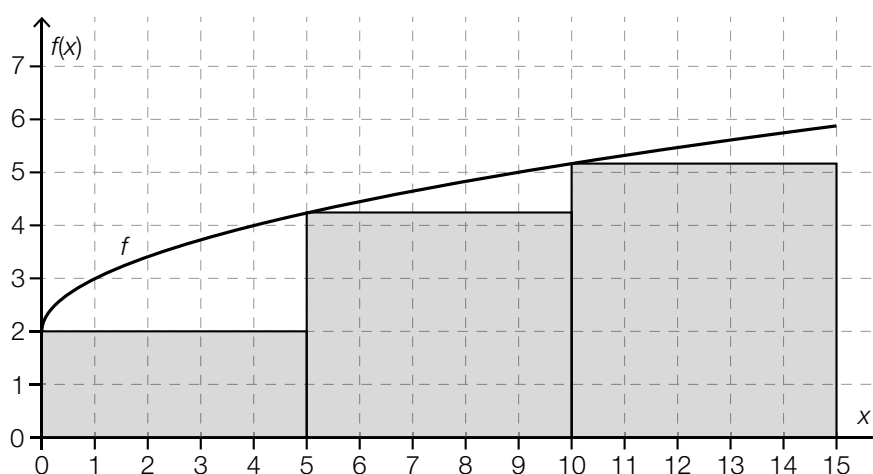

Task:

Put a cross next to each of the two expressions that produce a better approximation for the area A than the expression U .

$5 \cdot (f(0) + f(5) + f(10) + f(15))$	<input type="checkbox"/>
$2,5 \cdot (f(0) + f(2.5) + f(5) + f(7.5) + f(10) + f(12.5))$	<input type="checkbox"/>
$\int_0^{15} f(x) dx$	<input type="checkbox"/>
$f(0) \cdot 15$	<input type="checkbox"/>
$f(15) \cdot 5$	<input type="checkbox"/>

[0/1 point]

Task 18

Work Done by Stretching a Spring

A spring with a spring constant $k = 40 \text{ N/m}$ is stretched from a state of equilibrium $s_0 = 0 \text{ m}$ by $h = 0.08 \text{ m}$.

The work done by stretching the spring W (in joules) can be calculated using the expression below.

$$W = \int_{s_0}^{s_0+h} k \cdot s \, ds$$

Task:

Determine the work done by stretching the spring as described above.

[0/1 point]

Task 19

Box Plot and Statistical Measures

From a box plot, certain statistical measures can be determined.

Task:

Put a cross next to each of the two statistical measures that generally cannot be determined from a box plot.

median	<input type="checkbox"/>
mean	<input type="checkbox"/>
mode	<input type="checkbox"/>
range	<input type="checkbox"/>
maximum	<input type="checkbox"/>

[0/1 point]

Task 20

Estimate

In a particular random experiment, the event E occurs with probability $P(E)$.

In a series of experiments, this random experiment is conducted a times ($a \in \mathbb{N}$ and $a > 1$).

During this series of experiments, the event E occurs b times ($b \in \mathbb{N}$).

An estimate p of the unknown probability $P(E)$ is to be determined.

Task:

Write down a formula in terms of a and b with which p can be calculated.

$p =$ _____

[0/1 point]

Task 21

Probabilities

The random variable X can only take the values 0, 1, 2 and 3.

The following statements hold: $P(X = 1) = 0.1$ and $P(X > 1) = 0.6$.

Task:

Put a cross next to each of the two true statements.

$P(X \leq 2) = 0.3$	<input type="checkbox"/>
$P(X < 2) = 0.4$	<input type="checkbox"/>
$P(X = 0) = 0$	<input type="checkbox"/>
$P(X \geq 0) = 0.9$	<input type="checkbox"/>
$P(X \geq 1) = 0.7$	<input type="checkbox"/>

[0/1 point]

Task 22

Faulty Devices

According to experience, 2.5 % of the devices that are distributed by a particular company are faulty. The binomially distributed random variable X gives the number of faulty devices in a random sample of size n . The expectation value is $E(X) = 20$.

Task:

Determine the size n of the random sample.

$n =$ _____

[0/1 point]

Task 23

Chocolate Figurines

According to experience, 1 % of the chocolate figurines produced in a particular chocolate factory are flawed.

During a particular quality control check, 500 chocolate figurines are selected at random. Each chocolate figurine has the same probability of being flawed (1 %), independent of the other chocolate figurines.

Task:

Determine the probability that at most 2 chocolate figurines are flawed in this quality control check.

[0/1 point]

Task 24

Election Forecast

Before a particular election, 500 people were selected at random and independently from each other, and they participated in a survey. Of these people, 35 % said that they would vote for party A. For the results of the survey, the γ -confidence interval that is symmetrical about this relative proportion is given as $[0.315, 0.385]$ for the unknown proportion of the voters for party A. A normal approximation to the binomial distribution was used to calculate this confidence interval.

Task:

Determine γ .

[0/1 point]

Task 1

Basic Operations

For two integers a, b where $a < 0$ and $b < 0$, holds: $b = 2 \cdot a$.

Task:

Which of the following calculations always result in a natural number?

Put a cross next to each of the two correct calculations.

$a + b$	<input type="checkbox"/>
$b : a$	<input type="checkbox"/>
$a : b$	<input type="checkbox"/>
$a \cdot b$	<input type="checkbox"/>
$b - a$	<input type="checkbox"/>

[0/1 point]

Task 2

Stopping Distance

Student drivers learn in a driving school that the stopping distance s can be approximated by the following formula. In the formula, v is the speed of the vehicle (s in m, v in km/h).

$$s = \frac{v}{10} \cdot 3 + \left(\frac{v}{10}\right)^2$$

When driving “at sight”, the driver has to choose the speed of the vehicle in such a way that stopping within the viewable distance is possible at any moment. Viewable distance means the length of the road visible for the driver.

Task:

Determine the maximum permissible speed when the viewable distance is 25 m.

The maximum permissible speed is \approx _____ km/h.

[0/1 point]

Task 3

Solving Inequalities

Below, you will find two linear inequalities.

I: $7 \cdot x + 67 > -17$

II: $-25 - 4 \cdot x > 7$

Task:

Find all real numbers x that solve both inequalities.
Write down the set of these numbers as an interval.

[0/1 point]

Task 4

Vertices of a Cuboid

The diagram below shows a cuboid. Its vertices A , B , C and E are shown in the diagram.

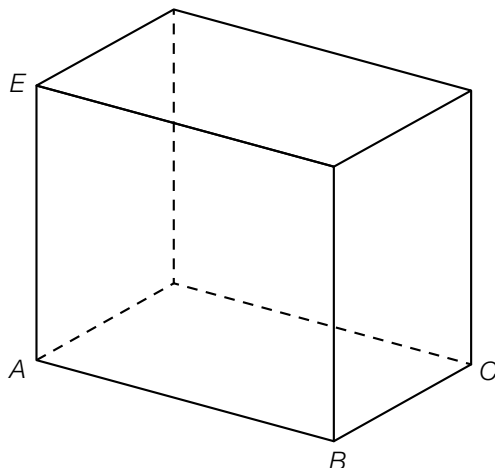

Task:

For the other vertices of the cuboid, R , S and T , the following relationships hold:

$$R = E + \overrightarrow{AB}$$

$$S = A + \overrightarrow{AE} + \overrightarrow{BC}$$

$$T = E + \overrightarrow{BC} - \overrightarrow{AE}$$

In the diagram above, label the vertices R , S and T in a clearly visible way.

[0/1 point]

Task 5

Vector Equation of a Line

The diagram below shows the line g . The points marked on the line g have integer coordinates.

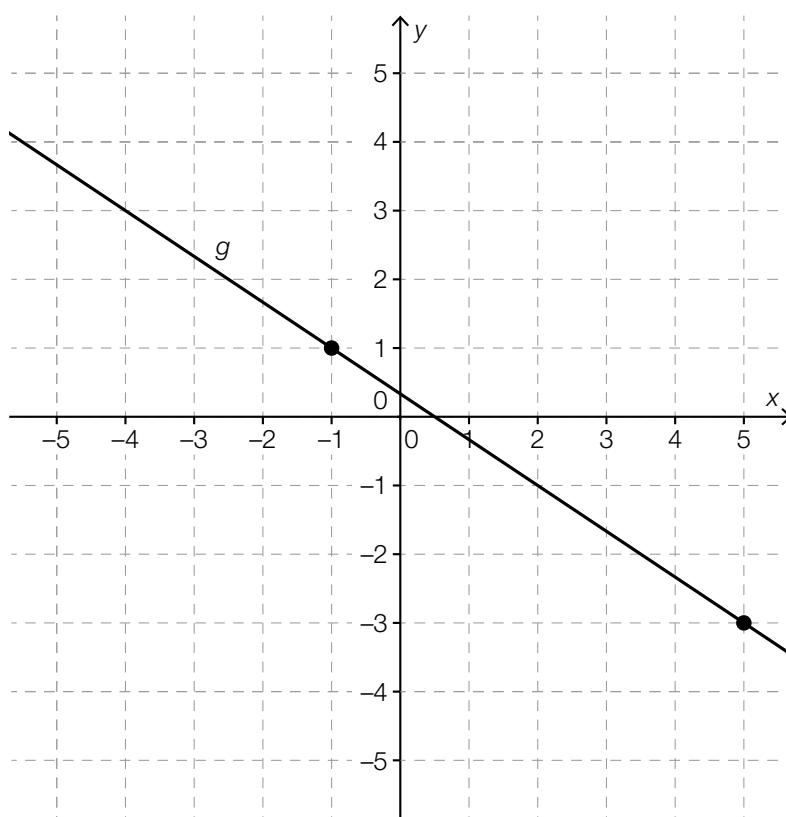

Task:

Complete the following vector equation of the line g by writing down the values of a and b with $a, b \in \mathbb{R}$.

$$g: X = \begin{pmatrix} a \\ 3 \end{pmatrix} + t \cdot \begin{pmatrix} 3 \\ b \end{pmatrix} \text{ where } t \in \mathbb{R}$$

$a =$ _____

$b =$ _____

[0/1 point]

Task 6

Triangle

The following triangle with sides r , s and t is given.

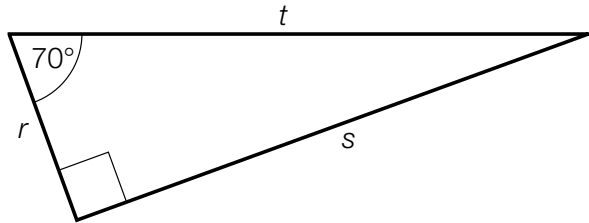

Task:

Determine the ratio $\frac{r}{t}$ for this triangle.

[0/1 point]

Task 7

Matching Functions

The formula $F = \frac{a^2 \cdot b}{c^n} + d$, where $a, b, c, d \in \mathbb{R}$, $n \in \mathbb{N}$ and $c \neq 0$, $n \neq 0$, is given.

Assuming that only one of the quantities a, b, c, d or n is variable and all others are constant, F can be written as a function dependent of the respective variable.

Task:

Which of the relationships below describe a linear function (where domain and range are suitable)?

Put a cross next to both correct relationships.

$a \mapsto \frac{a^2 \cdot b}{c^n} + d$	<input type="checkbox"/>
$b \mapsto \frac{a^2 \cdot b}{c^n} + d$	<input type="checkbox"/>
$c \mapsto \frac{a^2 \cdot b}{c^n} + d$	<input type="checkbox"/>
$d \mapsto \frac{a^2 \cdot b}{c^n} + d$	<input type="checkbox"/>
$n \mapsto \frac{a^2 \cdot b}{c^n} + d$	<input type="checkbox"/>

[0/1 point]

Task 8

Unemployment Rate

A politician, who wants to highlight the successful employment policies of one of the governing parties, says, "The growth of the unemployment rate has decreased throughout the year."
 An opposition politician replies, "The unemployment rate has increased throughout the year."

Task:

The development of the unemployment rate throughout the year can be modelled by a function f in terms of the time.

Which of the following graphs shows the development of the unemployment rate throughout the year assuming that the statements of both politicians hold true?

Put a cross next to the correct graph.

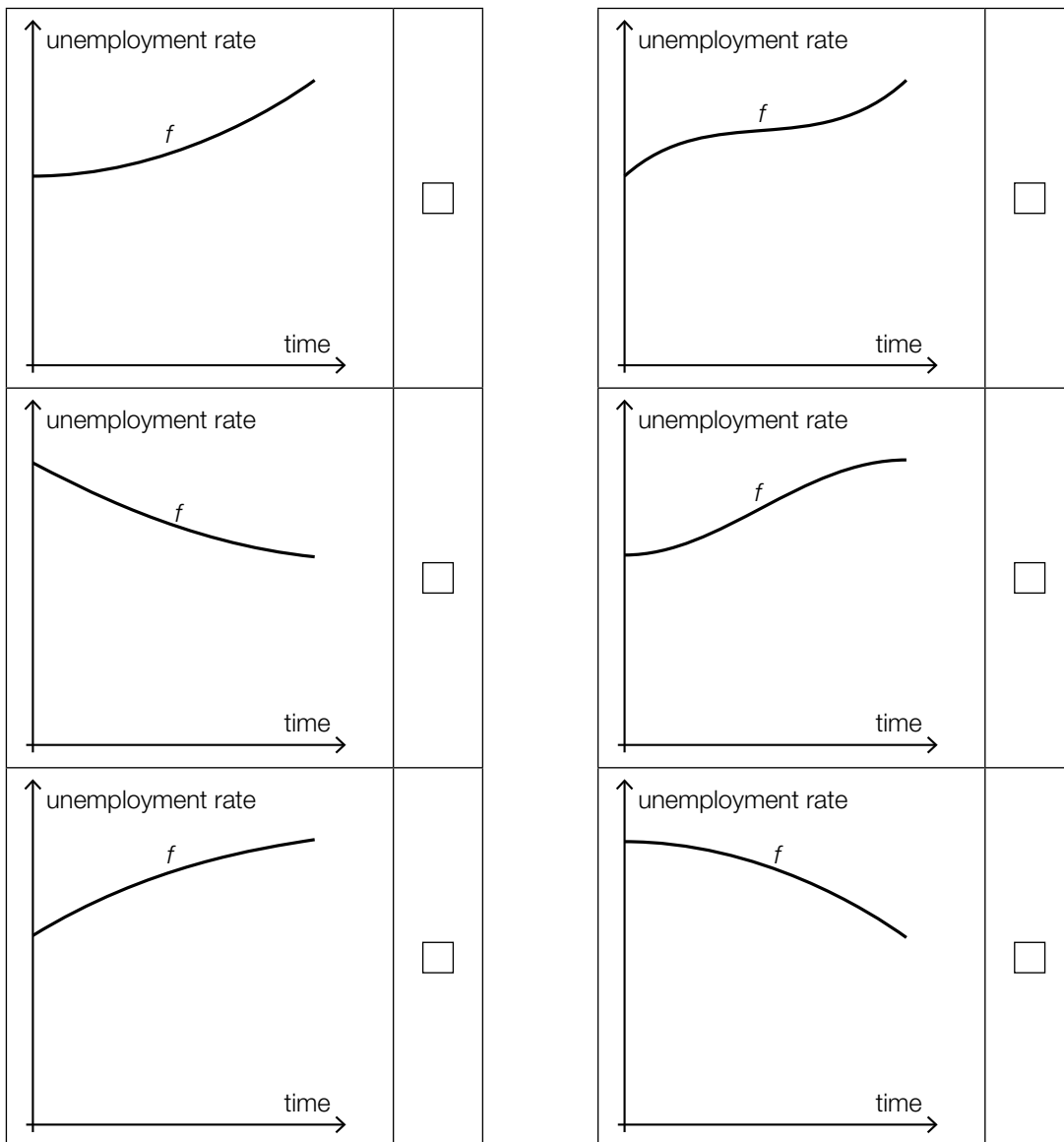

[0/1 point]

Task 9

Water Container

The liquid in a cuboid water container stands at the height of 40 cm. The liquid fully drains 8 minutes from the opening of the drain.

A linear function h with equation $h(t) = k \cdot t + d$, where $t \in [0, 8]$, can be used to describe the height of the liquid in the container (in cm) t minutes from the opening of the drain.

Task:

Write down the values of k and d .

$k =$ _____

$d =$ _____

[0/1 point]

Task 10

Shape of a Fourth Degree Polynomial Function

There are fourth degree polynomial functions that have exactly three zeros at x_1 , x_2 and x_3 , where $x_1, x_2, x_3 \in \mathbb{R}$ and $x_1 < x_2 < x_3$.

Task:

In the interval $[-4, 4]$ in the coordinate system below, sketch the shape of such a function f that has all three zeros in the interval $[-3, 3]$.

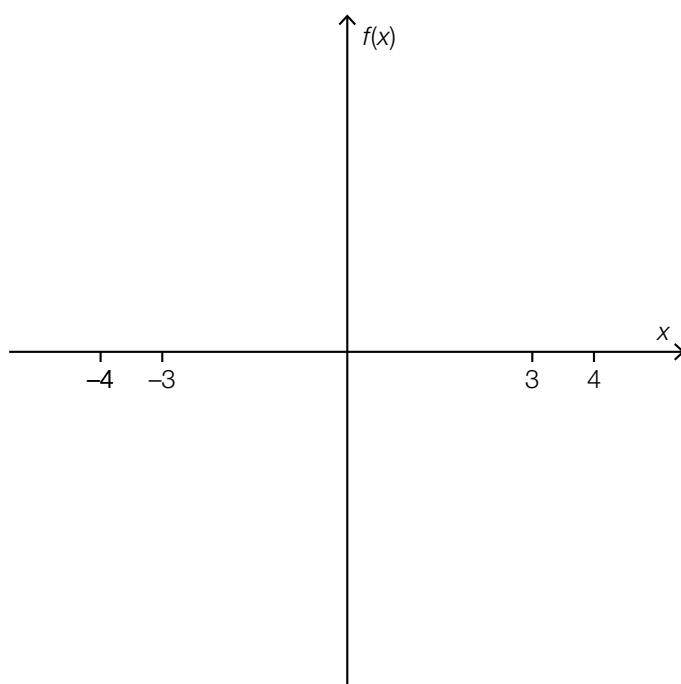

[0/1 point]

Task 11

Active Ingredient

The decrease in the active ingredient of a medication in the bloodstream can be modelled by an exponential function.

After one hour, 10 % of the initial amount has been broken down.

Task:

Determine the percentage of the original amount of the ingredient that remains in the bloodstream after a total of four hours.

_____ % of the initial amount

[0/1 point]

Task 12

Graphs of Two Trigonometric Functions

The following diagram shows the graphs of the functions $f_1: \mathbb{R} \rightarrow \mathbb{R}$ and $f_2: \mathbb{R} \rightarrow \mathbb{R}$ with equations $f_1(x) = a_1 \cdot \sin(b_1 \cdot x)$ and $f_2(x) = a_2 \cdot \sin(b_2 \cdot x)$ where $a_1, a_2, b_1, b_2 > 0$.

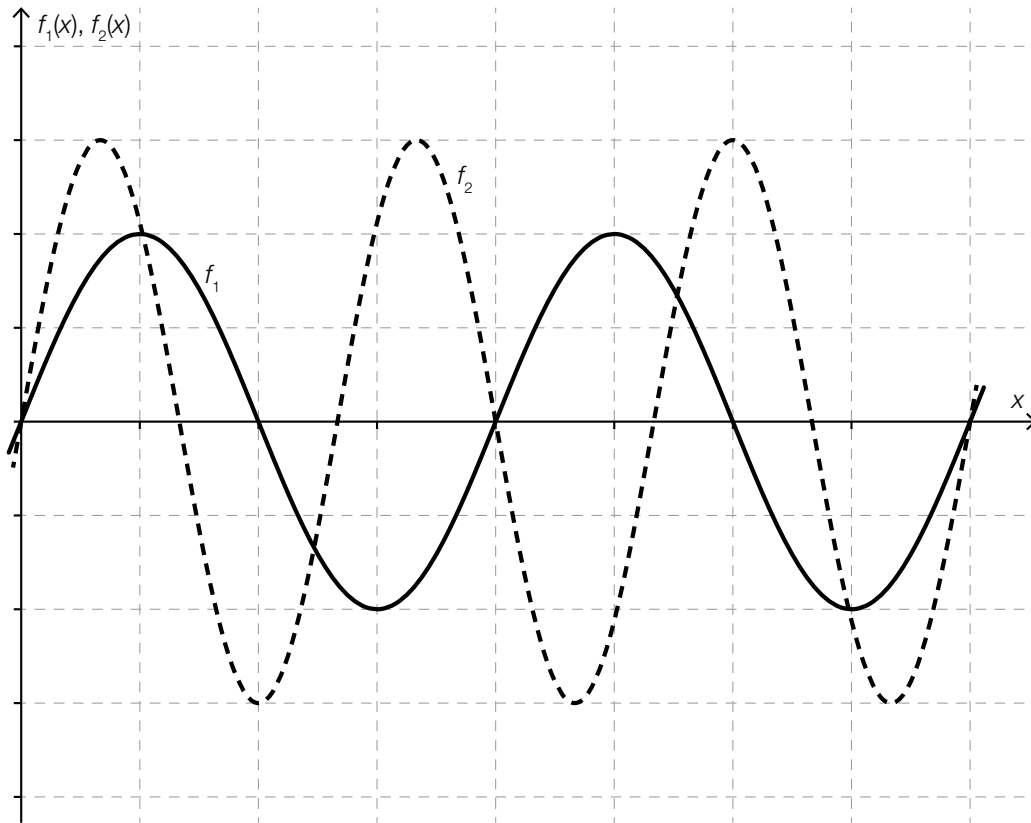

Task:

Complete the following sentence by putting a cross next to one of the given possibilities for each gap so that the sentence becomes a correct statement.

For the values of the parameters, _____ ① _____ and _____ ② _____ hold.

①	
$a_2 < a_1$	<input type="checkbox"/>
$a_1 \leq a_2 \leq 2 \cdot a_1$	<input type="checkbox"/>
$a_2 > 2 \cdot a_1$	<input type="checkbox"/>

②	
$b_2 < b_1$	<input type="checkbox"/>
$b_1 \leq b_2 \leq 2 \cdot b_1$	<input type="checkbox"/>
$b_2 > 2 \cdot b_1$	<input type="checkbox"/>

[0/1/2/1 point]

Task 13

Crime Statistics 2010–2011

The following table describes how many criminal cases were reported in the years 2010 and 2011 in each Austrian province.

Province	Reported crimes 2010	Reported crimes 2011
Burgenland (Burgenland)	9 306	10 391
Carinthia (Kärnten)	30 192	29 710
Lower Austria (Niederösterreich)	73 146	78 634
Upper Austria (Oberösterreich)	66 141	67 477
Salzburg (Salzburg)	29 382	30 948
Styria (Steiermark)	55 167	55 472
Tyrol (Tirol)	44 185	45 944
Vorarlberg (Vorarlberg)	20 662	20 611
Vienna (Wien)	207 564	200 820

Source: http://www.bmi.gv.at/cms/BK/publikationen/krim_statistik/files/2011/KrimStat_Entwicklung_2011.pdf [24.10.2016].

Task:

Determine the relative change in crime cases of Burgenland reported in the year 2011 compared to the year 2010.

[0/1 point]

Task 14

Financial Growth

An amount of € 100,000 is invested at a fixed annual interest rate. The table below provides information about the growth of the investment. In this table, x_n gives the value of the investment after n years ($n \in \mathbb{N}$).

n in years	x_n in euros
0	100 000
1	103 000
2	106 090
3	109 272.7

Task:

Suggest an equation that can be used to determine the value of the investment x_{n+1} based on the value of the investment x_n .

$$x_{n+1} = \underline{\hspace{15em}}$$

[0/1 point]

Task 15

Values of a Derivative Function

Let $f: \mathbb{R} \rightarrow \mathbb{R}$ be a function with equation $f(x) = 3 \cdot e^x$.

Task:

The statements given below refer to the properties of the function f or its derivative function f' . Put a cross next to each of the two true statements.

There is one point $x \in \mathbb{R}$ for which $f'(x) = 2$.	<input type="checkbox"/>
For all $x \in \mathbb{R}$, $f'(x) > f'(x + 1)$ holds.	<input type="checkbox"/>
For all $x \in \mathbb{R}$, $f'(x) = 3 \cdot f(x)$ holds.	<input type="checkbox"/>
There is one point $x \in \mathbb{R}$ for which $f'(x) = 0$.	<input type="checkbox"/>
For all $x \in \mathbb{R}$, $f'(x) \geq 0$ holds.	<input type="checkbox"/>

[0/1 point]

Task 16

Antiderivative

Let $f: \mathbb{R} \rightarrow \mathbb{R}$ be a function with equation $f(x) = a \cdot x^3$ with $a \in \mathbb{R}$.

Task:

Determine a such that the function $F: \mathbb{R} \rightarrow \mathbb{R}$ with equation $F(x) = 5 \cdot x^4 - 2$ is an antiderivative of f .

$a =$ _____

[0/1 point]

Task 17

Polynomial Function

The following diagram depicts the graph of a third degree polynomial function $f: \mathbb{R} \rightarrow \mathbb{R}$ in the interval $[-1, 7]$. The x -coordinates of all local maxima and minima and the point of inflexion of f in the interval $[-1, 7]$ are integers and can be read from the diagram.

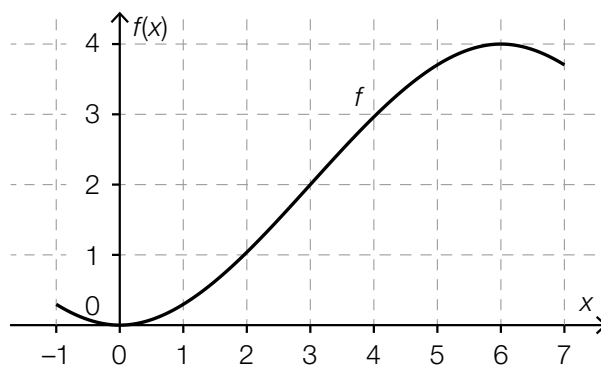

Task:

Put a cross next to each of the two correct statements about the function f .

$f''(3) = 0$	<input type="checkbox"/>
$f'(1) > f'(3)$	<input type="checkbox"/>
$f''(1) = f''(5)$	<input type="checkbox"/>
$f''(1) > f''(4)$	<input type="checkbox"/>
$f'(3) = 0$	<input type="checkbox"/>

[0/1 point]

Task 18

Areas of Regions

The diagram below shows the graph of the function $f: \mathbb{R} \rightarrow \mathbb{R}$ and two shaded regions.

The graph of the function f , the x -axis and the line g with equation $x = a$ enclose region **I** with area A_1 .

The graph of the function f , the x -axis and the line h with equation $x = b$ enclose region **II** with area A_2 .

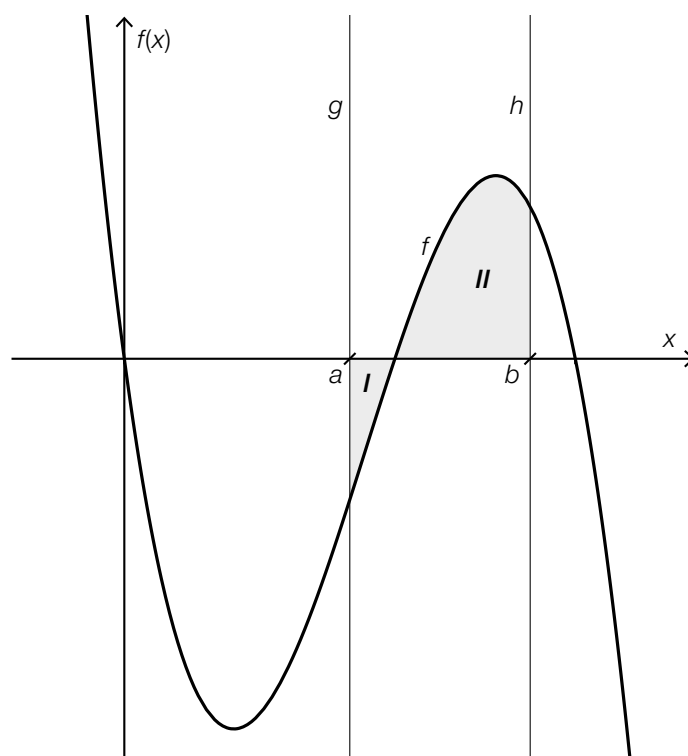

Task:

Write down the definite integral $\int_a^b f(x) dx$ using the areas A_1 and A_2 .

$$\int_a^b f(x) dx = \underline{\hspace{10cm}}$$

[0/1 point]

Task 19

Leisure Behaviour of Teenagers

400 teenagers were asked about their leisure behaviour. Among all respondents, 330 stated that they belong to a sports club, 146 stated that they play an instrument and 98 stated that they belong to a sports club and play an instrument as well.

The results of this survey have been documented in the following table.

	plays an instrument	does not play an instrument	total
belongs to a sports club	98		330
does not belong to a sports club			
total	146		400

Task:

Determine the relative frequency h of the teenagers that were asked who neither belong to a sports club nor play an instrument.

$h =$ _____

[0/1 point]

Task 20

Danger of Avalanches

During the winter months, the avalanche warning service publishes a daily *avalanche report*. This includes an assessment of the risk of avalanches according to five danger levels.

In a particular region, records of the danger levels were made during the winter of 2013/14. These records give a list of all the days with the according danger level 1 to 4. (There is no entry for danger level 5 in this list, as there was no day with danger level 5 during this period.) The following diagram shows the relative proportion of days with the respective danger level.

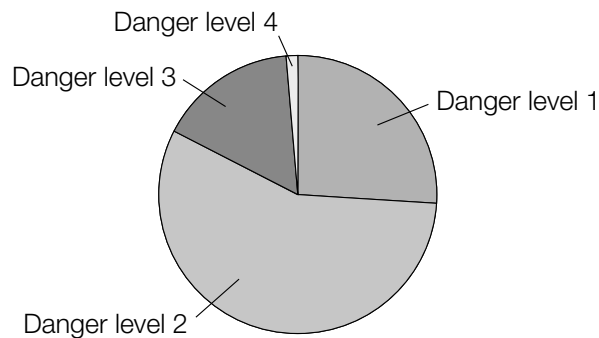

Task:

Justify why danger level 2 has to be the median of the data set that the diagram above is based on.

[0/1 point]

Task 21

Dice

A dice, where the sides are numbered 1, 2, 3, 4, 5 and 6, is used in a game. The dice is thrown three times. The following statement holds for each throw: the probability of any number being rolled is the same as for any other number.

Task:

Determine the probability p that a number that is divisible by 3 is thrown on the third throw.

$p =$ _____

[0/1 point]

Task 22

Frequency of Side Effects

Pharmaceutical companies are obliged to list all known side effects of a medication on the package leaflet. The information on the frequency of side effects are based on the following categories:

Frequency	Occurrence of Side Effects
Very common	More than 1 in 10 people under treatment experience side effects.
Common	Between 1 to 10 in 100 people under treatment experience side effects.
Uncommon	Between 1 to 10 in 1 000 people under treatment experience side effects.
Rare	Between 1 to 10 in 10 000 people under treatment experience side effects.
Very rare	Fewer than 1 in 10 000 people under treatment experience side effects.
Unknown	The frequency of side effects cannot be estimated based on the information available.

In the package leaflet of a medication, one particular side effect is categorised as “rare”. 50 000 people are treated with this medication independently from each other. A certain number of people experience this side effect.

Task:

Use the information given on the frequency of side effects above as probabilities and determine the minimum number of people expected to experience this side effect.

[0/1 point]

Task 23

Strike Probability

In a training session, a basketball player throws the ball at the basket six times in a row. If the ball falls into the basket, it is called strike. The probability of a strike for this player is 0.85 for each throw (irrespective of other throws).

Task:

Match each of the four events with the term (from among A to F) which describes the probability of this event occurring.

The player strikes exactly once.	
The player strikes not more than once.	
The player strikes at least once.	
The player strikes exactly twice.	

A	$1 - 0.85^6$
B	$0.15^6 + \binom{6}{1} \cdot 0.85^1 \cdot 0.15^5$
C	$1 - 0.15^6$
D	$0.85^6 + \binom{6}{1} \cdot 0.85^5 \cdot 0.15^1$
E	$6 \cdot 0.85 \cdot 0.15^5$
F	$\binom{6}{2} \cdot 0.85^2 \cdot 0.15^4$

[0/½/1 point]

Task 24

Confidence Interval

Someone wants to determine the unknown proportion p of voters who are going to vote for candidate A in an election and hires an opinion research institute to give an estimate of the proportion p . In the course of this estimation, 200 samples of the same size are drawn. For each of these samples, the respective 95 % confidence interval is determined.

Task:

Determine the expected number of intervals that contain the unknown proportion p .

[0/1 point]

Task 1

Sets of Numbers

Certain relationships hold between sets of numbers.

Task:

Put a cross next to each of the two correct statements.

$\mathbb{Z}^+ \subseteq \mathbb{N}$	<input type="checkbox"/>
$\mathbb{C} \subseteq \mathbb{Z}$	<input type="checkbox"/>
$\mathbb{N} \subseteq \mathbb{R}^-$	<input type="checkbox"/>
$\mathbb{R}^+ \subseteq \mathbb{Q}$	<input type="checkbox"/>
$\mathbb{Q} \subseteq \mathbb{C}$	<input type="checkbox"/>

[0/1 point]

Task 2

Simultaneous Linear Equations

Below, you will see a pair of simultaneous linear equations in the variables x_1 and x_2 . For the parameters a and b : $a, b \in \mathbb{R}$ holds.

$$\text{I: } 3 \cdot x_1 - 4 \cdot x_2 = a$$

$$\text{II: } \underline{b \cdot x_1 + x_2 = a}$$

Task:

Determine the values of the parameters a and b such that the solution to the pair of simultaneous linear equations is $L = \{(2, -2)\}$.

$$a = \underline{\hspace{10cm}}$$

$$b = \underline{\hspace{10cm}}$$

[0/1 point]

Task 3

Representation in a Coordinate System

The coordinate system below shows the vector \vec{v} as well as the points A and B . The vector \vec{v} has integer components and both of the points A and B have integer coordinates.

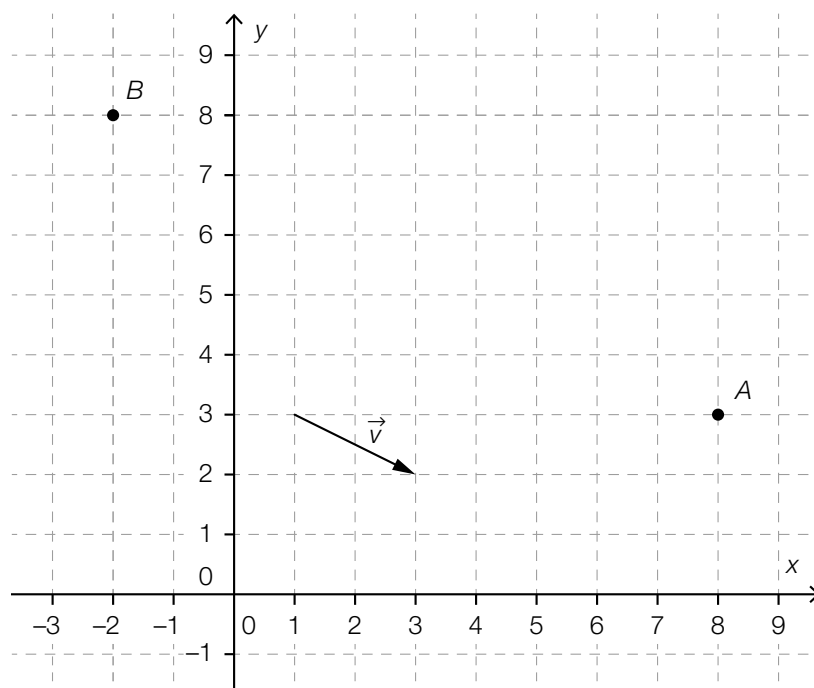

Task:

Determine the value of the parameter t such that the equation $B = A + t \cdot \vec{v}$ is satisfied.

$t =$ _____

[0/1 point]

Task 4

Equation of a Line

Let $A = (7,6)$, $M = (-1,7)$ and $N = (8,1)$ be points. A line g goes through the point A and is perpendicular to the line connecting the points M and N .

Task:

Write down an equation of the line g .

[0/1 point]

Task 5

Cone

A cone has a height of 6 cm. The angle between the axis of the cone and its curved surface is 32° .

Task:

Determine the radius r of the base of the cone.

$r \approx$ _____ cm

[0/1 point]

Task 6

Angle with the Same Sine

Let c be a real number where $0 < c < 1$. For the two distinct angles α and β , the following relationship holds: $\sin(\alpha) = \sin(\beta) = c$.

The angle α is an acute angle, and the angle β lies in the interval $(0^\circ, 360^\circ)$.

Task:

Which relationship holds between the angles α and β ?

Put a cross next to the correct relationship.

$\alpha + \beta = 90^\circ$	<input type="checkbox"/>
$\alpha + \beta = 180^\circ$	<input type="checkbox"/>
$\alpha + \beta = 270^\circ$	<input type="checkbox"/>
$\alpha + \beta = 360^\circ$	<input type="checkbox"/>
$\beta - \alpha = 270^\circ$	<input type="checkbox"/>
$\beta - \alpha = 180^\circ$	<input type="checkbox"/>

[0/1 point]

Task 7

Quadratic Function

Let $f: \mathbb{R} \rightarrow \mathbb{R}$ be a quadratic function where $f(x) = a \cdot x^2 + b \cdot x + c$ ($a, b, c \in \mathbb{R}$ and $a \neq 0$).

Task:

Complete the following sentence by putting a cross next to one of the given possibilities for each gap so that the sentence becomes a correct statement.

When _____ ① _____ holds, the function f definitely has _____ ② _____.

①	
$a < 0$	<input type="checkbox"/>
$b = 0$	<input type="checkbox"/>
$c > 0$	<input type="checkbox"/>

②	
a graph that is symmetrical about the vertical axis	<input type="checkbox"/>
two real zeros	<input type="checkbox"/>
a local minimum	<input type="checkbox"/>

[0/1 point]

Task 8

Oscillation of a String

The frequency f of the oscillation of a string on a musical instrument can be calculated using the following formula.

$$f = \frac{1}{2 \cdot l} \cdot \sqrt{\frac{F}{\rho \cdot A}}$$

l ... length of the string

A ... cross-sectional area of the string

ρ ... density of the material of the string

F ... force with which the string is held taut

Task:

Write down how the length l of the string should be changed if the string is to oscillate at double its original frequency and the other values (F , ρ , A) remain constant.

[0/1 point]

Task 9

Height of a Candle

A burning candle that was lit t hours ago has a height $h(t)$. The height of the candle can be approximated by $h(t) = a \cdot t + b$ where $a, b \in \mathbb{R}$.

Task:

Write down whether each of the coefficients a and b must be positive, negative or exactly zero.

[0/1 point]

Task 10

Parabolas

The graphs of the functions $f: \mathbb{R} \rightarrow \mathbb{R}$ where $f(x) = a \cdot x^2$ and $a \in \mathbb{R} \setminus \{0\}$ are parabolas. For $a = 1$ the graph is often known as the *standard parabola*. Depending on the value of the parameter a , the parabolas obtained are “steeper” or “less steep” than the standard parabola and either “concave down” or “concave up”.

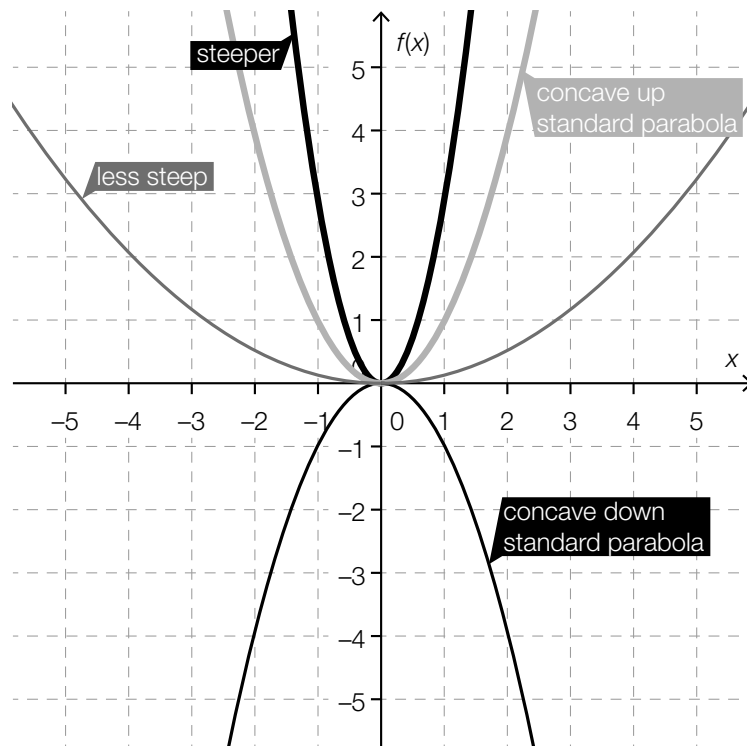

Task:

Four parabolas are described below. Match each of the four descriptions to the condition (from A to F) that the parameter a must satisfy.

In comparison to the standard parabola, the parabola is “less steep” and “concave up”.	
In comparison to the standard parabola, the parabola is neither “steeper” nor “less steep” but “concave down”.	
In comparison to the standard parabola, the parabola is “steeper” and “concave down”.	
In comparison to the standard parabola, the parabola is “steeper” and “concave up”.	

A	$a < -1$
B	$a = -1$
C	$-1 < a < 0$
D	$0 < a < 1$
E	$a = 1$
F	$a > 1$

[0/½/1 point]

Task 11

Function with a Particular Property

For a non-constant function $f: \mathbb{R} \rightarrow \mathbb{R}$ the relationship $f(x + 1) = 3 \cdot f(x)$ holds for all $x \in \mathbb{R}$.

Task:

Write down an equation of one such function f .

$f(x) =$ _____

[0/1 point]

Task 12

Length of a Period

Let $f: \mathbb{R} \rightarrow \mathbb{R}$ be a function where $f(x) = \frac{1}{3} \cdot \sin\left(\frac{3 \cdot \pi}{4} \cdot x\right)$.

Task:

Determine the length of the (smallest) period p of the function f .

$p =$ _____

[0/1 point]

Task 13

Difference Quotient

The graph of a function f goes through the points $P = (-1, 2)$ and $Q = (3, f(3))$.

Task:

Determine the value of $f(3)$ such that the difference quotient of f in the interval $[-1, 3]$ has the value 1.

$f(3) =$ _____

[0/1 point]

Task 14

Derivative and Antiderivative

Let $f: \mathbb{R} \rightarrow \mathbb{R}$ be a polynomial function.

Task:

Two of the following statements about f are definitely true.

Put a cross next to each of the two correct statements.

The function f has exactly one antiderivative F .	<input type="checkbox"/>
The function f has exactly one derivative f' .	<input type="checkbox"/>
If F is an antiderivative of f , then $f' = F$ holds.	<input type="checkbox"/>
If F is an antiderivative of f , then $F'' = f'$ holds.	<input type="checkbox"/>
If F is an antiderivative of f , then $\int_0^1 F(x) dx = f(1) - f(0)$ holds.	<input type="checkbox"/>

[0/1 point]

Task 15

Velocity and Acceleration

The diagrams below show the graphs of four acceleration functions (a_1, a_2, a_3, a_4) and six velocity functions ($v_1, v_2, v_3, v_4, v_5, v_6$) in terms of time t .

Task:

Match each of the graphs from a_1 to a_4 to the corresponding graph from v_1 to v_6 (from A to F).

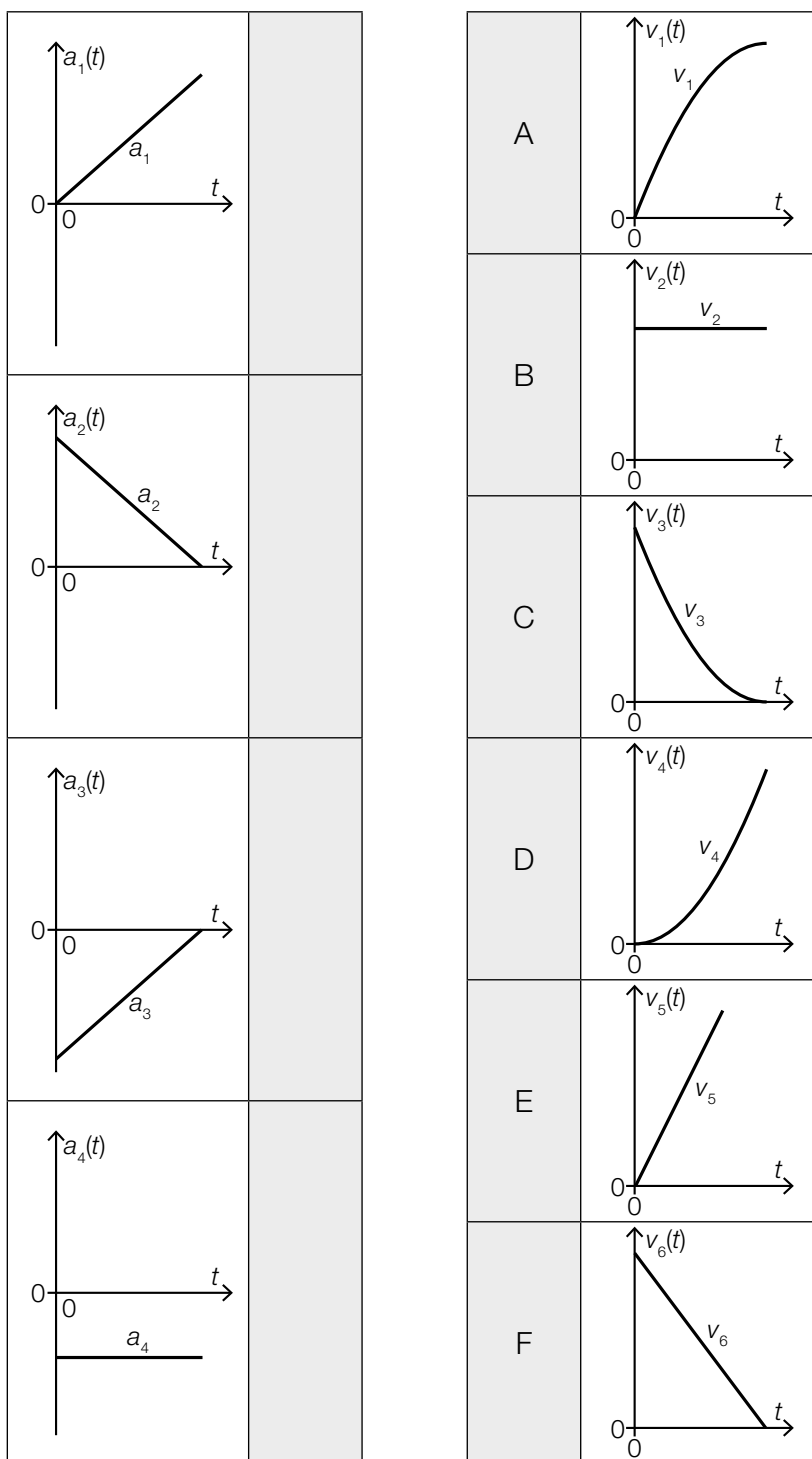

[0/1/2/1 point]

Task 16

Properties of a Third Degree Polynomial Function

Let f be a third degree polynomial function. At the points x_1 and x_2 where $x_1 < x_2$, the following conditions hold:

$$f'(x_1) = 0 \text{ and } f''(x_1) < 0$$

$$f'(x_2) = 0 \text{ and } f''(x_2) > 0$$

Task:

Put a cross next to each of the two statements that are definitely true for the function f .

$f(x_1) > f(x_2)$	<input type="checkbox"/>
There exists one further point x_3 where $f'(x_3) = 0$.	<input type="checkbox"/>
In the interval $[x_1, x_2]$ there exists a point x_3 where $f(x_3) > f(x_1)$.	<input type="checkbox"/>
In the interval $[x_1, x_2]$ there exists a point x_3 where $f''(x_3) = 0$.	<input type="checkbox"/>
In the interval $[x_1, x_2]$ there exists a point x_3 where $f'(x_3) > 0$.	<input type="checkbox"/>

[0/1 point]

Task 17

Determining a Coefficient

Let $f: \mathbb{R} \rightarrow \mathbb{R}$ be a function where $f(x) = a \cdot x^2 + 2$ with $a \in \mathbb{R}$.

Task:

Write down the value of the coefficient a such that the equation $\int_0^1 f(x) dx = 1$ is satisfied.

$a =$ _____

[0/1 point]

Task 18

Height of an Object

An object is thrown vertically upwards from a height of 1 m above the Earth's surface. The velocity of the object after t seconds is modelled by the function v where $v(t) = 15 - 10 \cdot t$ ($v(t)$ in metres per second, t in seconds).

Task:

Write down the height of the object (in metres) above the Earth's surface after 2 s.

[0/1 point]

Task 19

Density of Cars

Data about the number of cars per 1 000 inhabitants has been collected in 32 European countries. The histogram below has been created based on this data. The absolute frequencies of the countries are represented by areas of rectangles.

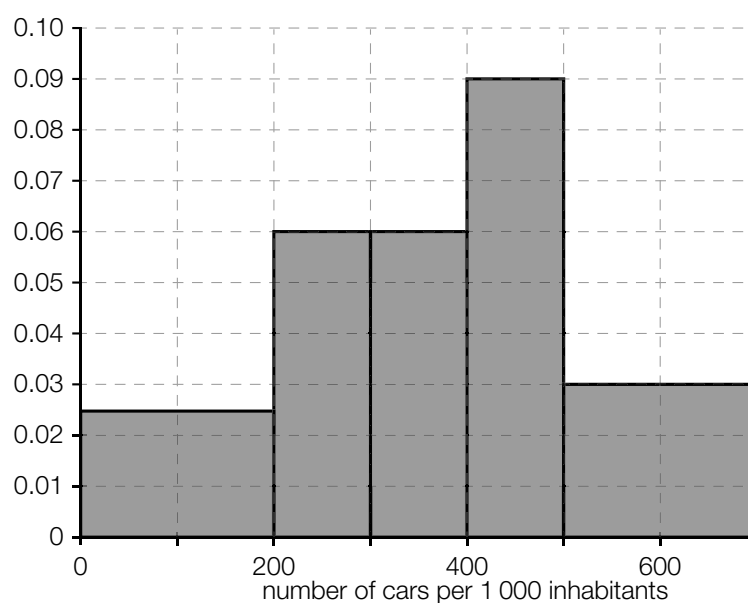

Task:

Determine in how many countries the number of cars per 1 000 inhabitants lies between 500 and 700 cars.

Number of countries = _____

[0/1 point]

Task 20

Data Set

Below, you will see an ordered data set. One of the values is k where $k \in \mathbb{R}$.

1	2	3	5	k	8	8	8	9	10
---	---	---	---	-----	---	---	---	---	----

Task:

Determine the value of k such that the mean of the whole data set has the value 6.

$k =$ _____

[0/1 point]

Task 21

Probability of Selection

There are five balls in a container. Two balls are removed from the container one after the other without replacement (it can be assumed that the removal of any two balls is equally likely). Two of the five balls in the container are blue; the other balls are red. The probability of selecting a blue ball second is given by p .

Task:

Write down the probability p .

$p =$ _____

[0/1 point]

Task 22

Playing Cards

Five playing cards (three Kings and two Queens) are shuffled and laid face down on a table. As part of a game, Laura turns the cards over one by one and leaves them face up on the table until the first Queen appears.

The random variable X gives the number of cards lying face up at the end of a game.

Task:

Determine the expectation value of the random variable X .

$E(X) =$ _____

[0/1 point]

Task 23

Rolling Doubles

In a game, two dice are rolled in each round. If the dice land on the same number, then the player has *rolled a double*. The probability of rolling a double is $\frac{1}{6}$.



Image source: BMBWF

Task:

Eight rounds (independent of each other) are played. The random variable X gives the number of doubles rolled.

Determine the probability that the number X of doubles rolled is less than the expectation value $E(X)$.

[0/1 point]

Task 24

Opinion Poll

An opinion poll collected responses to the question: "If there were an election this Sunday, which party would you vote for?". The options given in the opinion poll were the parties *A* and *B*, and 234 out of the 1 000 people asked said that they would vote for Party *A*. In the election that followed, the actual proportion of people who voted for Party *A* was 29.5 %.

Task:

Based on the results of the opinion poll, write down a symmetrical 95 % confidence interval for the (unknown) proportion of votes for Party *A* and state whether the actual proportion falls within this interval.

[0/1 point]

Task 1

Equivalent Equations

The following equation is given: $\frac{x}{2} - 4 = 3$ in $x \in \mathbb{R}$.

Task:

Put a cross next to each of the two equations in $x \in \mathbb{R}$, that are equivalent to the given equation.

$x - 4 = 6$	<input type="checkbox"/>
$\frac{x}{2} = -1$	<input type="checkbox"/>
$\frac{x}{2} - 3 = 4$	<input type="checkbox"/>
$\frac{x-8}{2} = 3$	<input type="checkbox"/>
$\left(\frac{x}{2} - 4\right)^2 = 9$	<input type="checkbox"/>

[0/1 point]

Task 2

Statistics on Traffic Accidents

The following data refers to traffic accidents in the time range from 2014 to 2016.

A ... number of traffic accidents in the year 2014, of which a % include human injuries

B ... number of traffic accidents in the year 2015, of which b % include human injuries

C ... number of traffic accidents in the year 2016, of which c % include human injuries

Task:

Write down an expression that describes the total number N of traffic accidents which include human injuries in the time range from 2014 to 2016.

$N =$ _____

[0/1 point]

Task 3

Lion Pack

A pack of lions consists of lionesses and male lions. The number of male lions in this specific pack is modelled by m , the number of lionesses as w .

The following two equations contain information regarding this pack.

$$m + w = 21$$

$$4 \cdot m + 1 = w$$

Task:

Put a cross next to each of the two correct statements regarding this pack.

There are more male lions than lionesses in this pack.	<input type="checkbox"/>
The number of lionesses is more than four times the number of male lions.	<input type="checkbox"/>
The number of male lions is 1 smaller than the number of lionesses.	<input type="checkbox"/>
The total number of lions (male lions and lionesses) is greater than 20 lions.	<input type="checkbox"/>
The quadruple number of male lions is 1 greater than the number of lionesses.	<input type="checkbox"/>

[0/1 point]

Task 4

Quadratic Equation

The quadratic equation $x^2 + r \cdot x + s = 0$ in which $x \in \mathbb{R}$ applies with $r, s \in \mathbb{R}$ is given.

Task:

Match each of the four solution possibilities to its corresponding statement about the parameters r and s (from A to F), so that it always contains the specific solution case.

The quadratic equation doesn't have a real solution.	
The quadratic equation only holds one real solution $x = -\frac{r}{2}$.	
The quadratic equation has the real solutions $x_1 = 0$ and $x_2 = -r$.	
The quadratic equation has the real solutions $x_1 = -\sqrt{-s}$ and $x_2 = \sqrt{-s}$.	

A	$\frac{r^2}{4} = s$
B	$\frac{r^2}{4} - s > 0$ with $r, s \neq 0$
C	$r \in \mathbb{R}, s > 0$
D	$r = 0, s < 0$
E	$r \neq 0, s = 0$
F	$r = 0, s > 0$

[0/½/1 point]

Task 5

A Parallel Line through a Point

The following coordinate system shows the graph of the line g . The marked points on the graph g have integer coordinates.

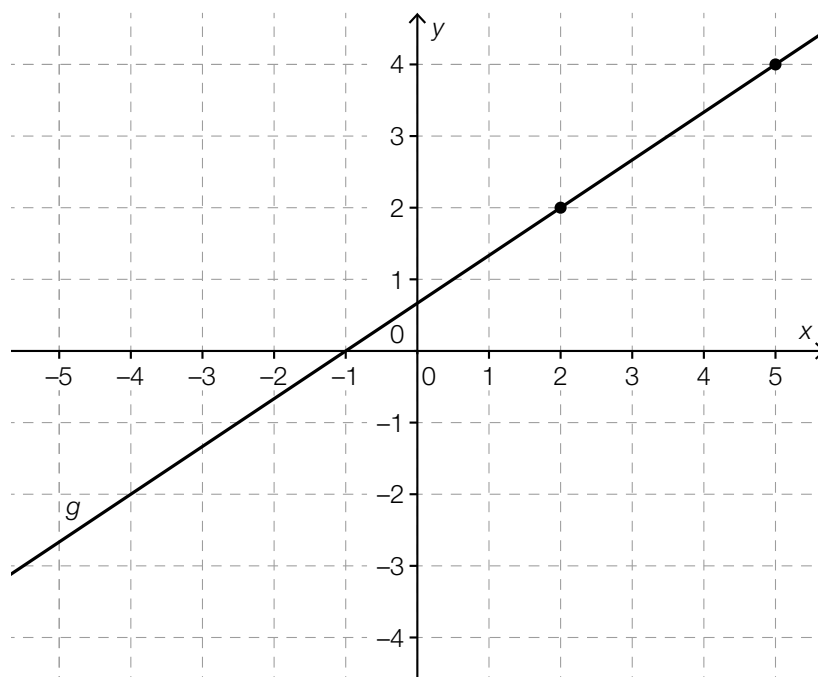

Task:

Give a vector equation of the line h that goes through the point $(3, -1)$ and is parallel to g .

$h: X =$ _____

[0/1 point]

Task 6

Depth Perception

When visualizing an object the direction of sight from both eyes enclose an angle ε . In the following scenario the object G is the same distance g from both eyes A_1 and A_2 . The distance between the eyes is described by d .

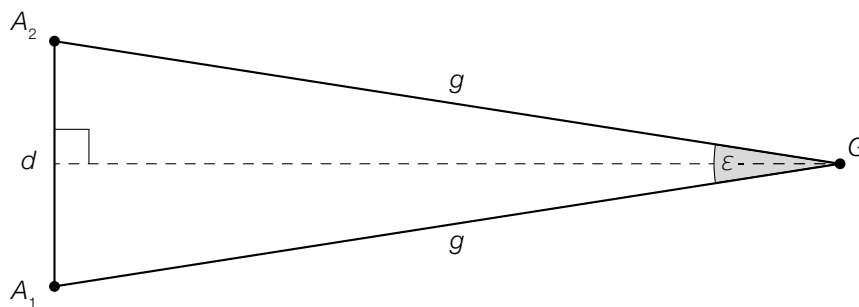

Task:

Write down an expression for the distance g in terms of the distance between the eyes d and the angle ε .

$g =$ _____

[0/1 point]

Task 7

Function of Profit

The following diagram shows a linear cost function $K: x \mapsto K(x)$ as well as a linear revenue function $E: x \mapsto E(x)$ for which $x \in [0, 6]$ applies.

The profit function $G: x \mapsto G(x)$ holds for all $x \in [0, 6]$: $G(x) = E(x) - K(x)$.

Task:

Draw the graph of G into the following diagram.

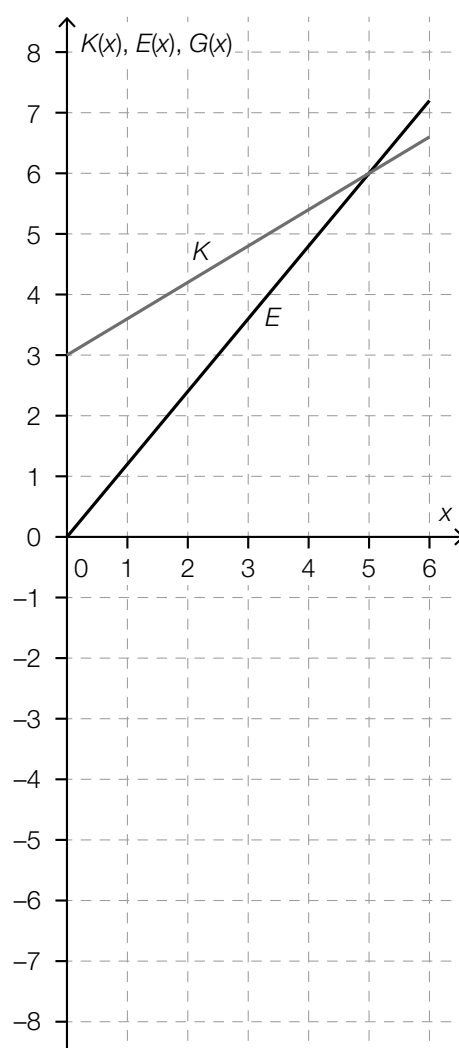

[0/1 point]

Task 8

Functional Coherencies

The following equation $w = \frac{y \cdot z^2}{2 \cdot x}$ with $w, x, y, z \in \mathbb{R}^+$ is given.

The given equations show the functional coherencies between two variables when the other two are assumed to be constants.

Task:

Put a cross next to each of the two correct answers.

Assuming z is dependent on x , then $z: \mathbb{R}^+ \rightarrow \mathbb{R}^+, x \mapsto z(x)$ is an exponential function.	<input type="checkbox"/>
Assuming w is dependent on z , then $w: \mathbb{R}^+ \rightarrow \mathbb{R}^+, z \mapsto w(z)$ is a quadratic function.	<input type="checkbox"/>
Assuming w is dependent on x , then $w: \mathbb{R}^+ \rightarrow \mathbb{R}^+, x \mapsto w(x)$ is a linear function.	<input type="checkbox"/>
Assuming y is dependent on z , then $y: \mathbb{R}^+ \rightarrow \mathbb{R}^+, z \mapsto y(z)$ is a polynomial function with degree 2.	<input type="checkbox"/>
Assuming x is dependent on y , then $x: \mathbb{R}^+ \rightarrow \mathbb{R}^+, y \mapsto x(y)$ is a linear function.	<input type="checkbox"/>

[0/1 point]

Task 9

Drawing a Graph

The following characteristics of a linear function f are known:

- The gradient of f is -0.4 .
- The function value of f at 2 is 1.

Task:

Draw the graph of f into the coordinate system below for the interval $[-7, 7]$.

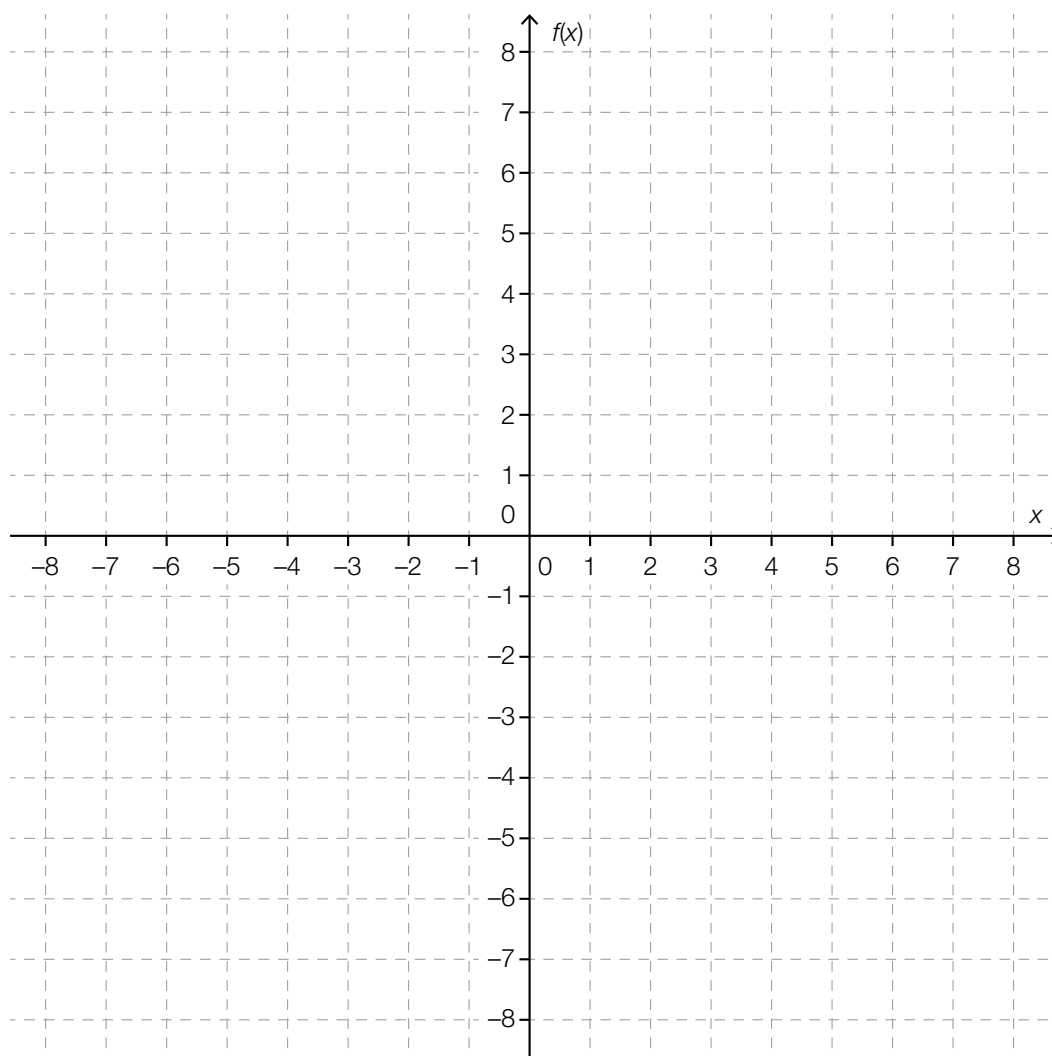

[0/1 point]

Task 10

Gross Income and Net Income

On the website of the ministry for finance one can find a gross-net-calculator which calculates the respective net income based on the monthly gross income.

The following table shows some incomes:

gross income in €	1 500	2 000	2 500
net income in €	1 199	1 483	1 749

Task:

By using data from the table, show that there is no linear coherency between the gross income and the net income.

[0/1 point]

Task 11

Interest

A capital investment K_0 is placed in a savings account which bears an interest rate of 1 % (per year).

For the following task it may be assumed that all taxes and fees need not be considered and that no further deposits or payments are made.

Task:

Calculate the number of years until the capital K_0 , at a constant interest rate, is doubled.

[0/1 point]

Task 12

Sine Function

The function $f: \mathbb{R} \rightarrow \mathbb{R}$ with $f(x) = a \cdot \sin\left(\frac{\pi \cdot x}{b}\right)$ with $a, b \in \mathbb{R}^+$.

Task:

Include the parameters a and b in the illustration by marking on the appropriate axis, so that the graph pictured is equivalent to the graph of the function f .

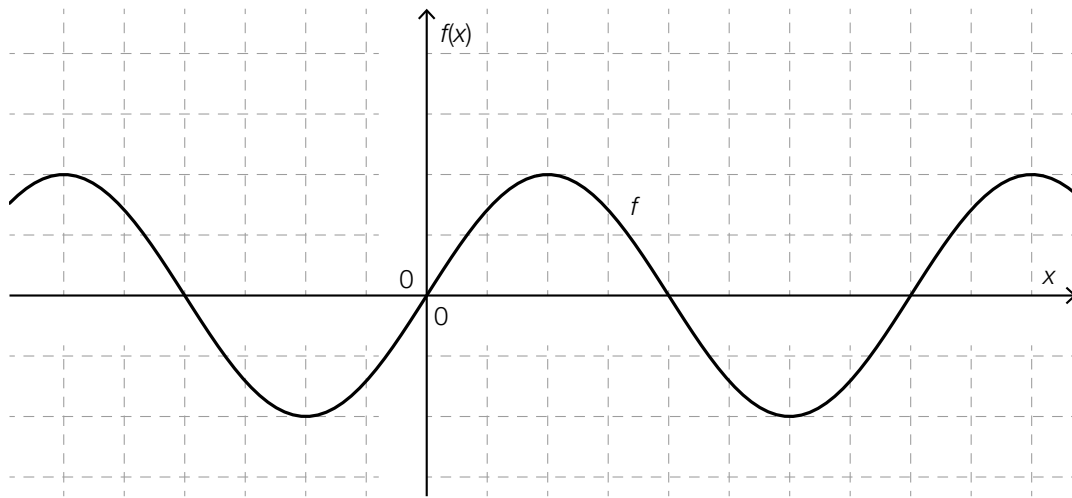

[0/1 point]

Task 13

Difference Quotient and Differential Quotient

The following diagram shows the graph of a second degree polynomial function f . Furthermore, there are four points marked along the graph with the x -coordinates x_1 , x_2 , x_3 and x_4 .

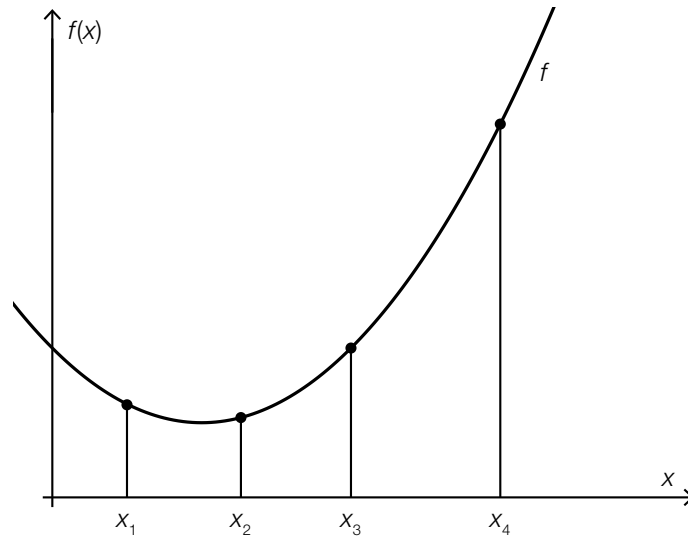

Task:

Put a cross next to each of the two statements which are correct for the function f .

The difference quotient for the interval $[x_1, x_2]$ is smaller than the differential quotient at the position x_1 .	<input type="checkbox"/>
The difference quotient for the interval $[x_1, x_3]$ is smaller than the differential quotient at the position x_3 .	<input type="checkbox"/>
The difference quotient for the interval $[x_1, x_4]$ is smaller than the differential quotient at the position x_2 .	<input type="checkbox"/>
The difference quotient for the interval $[x_2, x_4]$ is greater than the differential quotient at the position x_2 .	<input type="checkbox"/>
The difference quotient for the interval $[x_3, x_4]$ is greater than the differential quotient at the position x_4 .	<input type="checkbox"/>

[0/1 point]

Task 14

Motion

An object starts its linear motion at the time $t = 0$.

The function v assigns every time t to a velocity $v(t)$ of the object at the time t (t in s, $v(t)$ in m/s).

Task:

Interpret the equation $v'(3) = 1$ in the given context with use of the appropriate unit.

[0/1 point]

Task 15

Concentration of a Medicinal Substance

A patient is given a medicinal substance intravenously every day at 8 a. m. The concentration of the substance in the patient's blood on day t directly before the next dose of the substance is described as c_t (c_t in milligrams per litre).

For $t \in \mathbb{N}$: $c_{t+1} = 0.3 \cdot (c_t + 4)$ applies.

Task:

Interpret the value 4 in the equation in the given context with use of the appropriate unit.

[0/1 point]

Task 16

Graphs of Derivatives

Below, there are four graphs of the functions f_1 to f_4 as well as the graphs of six functions (A through F).

Task:

Match each of the four graphs of the functions f_1 to f_4 to the corresponding graph (from A to F) that is the derivative of this function.

<p>Graph of $f_1(x)$ vs x. The function is in the second quadrant, increasing from $-\infty$ to 0 as x increases. The origin is marked with 0.</p>		A	<p>Graph of $f'_i(x)$ vs x. The function is in the first quadrant, increasing from 0 to $+\infty$ as x increases. The origin is marked with 0.</p>
<p>Graph of $f_2(x)$ vs x. The function is in the third quadrant, decreasing from 0 to $-\infty$ as x increases. The origin is marked with 0.</p>		B	<p>Graph of $f'_i(x)$ vs x. The function is in the second quadrant, decreasing from $+\infty$ to 0 as x increases. The origin is marked with 0.</p>
<p>Graph of $f_3(x)$ vs x. The function is in the first quadrant, increasing from $-\infty$ to $+\infty$ as x increases. The origin is marked with 0.</p>		C	<p>Graph of $f'_i(x)$ vs x. The function is in the first quadrant, decreasing from $+\infty$ to 0 as x increases. The origin is marked with 0.</p>
<p>Graph of $f_4(x)$ vs x. The function is in the second quadrant, increasing from 0 to $+\infty$ as x increases. The origin is marked with 0.</p>		D	<p>Graph of $f'_i(x)$ vs x. The function is in the third quadrant, decreasing from 0 to $-\infty$ as x increases. The origin is marked with 0.</p>
		E	<p>Graph of $f'_i(x)$ vs x. The function is in the second quadrant, decreasing from $+\infty$ to $-\infty$ as x increases. The origin is marked with 0.</p>
		F	<p>Graph of $f'_i(x)$ vs x. The function is in the first quadrant, decreasing from $+\infty$ to 0 as x increases. The origin is marked with 0.</p>

[0/1/2/1 point]

Task 17

Characteristics of Polynomial Functions

Let $f: \mathbb{R} \rightarrow \mathbb{R}$ be a polynomial function and $a, b \in \mathbb{R}$ with $a < b$.

Task:

Complete the following sentence by putting a cross next to one of the given possibilities for each gap so that the sentence is a certainly correct statement.

If for all $x \in (a, b)$ _____ ① _____ holds, then the function f is _____ ② _____ in the interval (a, b) .

①	
$f(x) > 0$	<input type="checkbox"/>
$f'(x) < 0$	<input type="checkbox"/>
$f''(x) > 0$	<input type="checkbox"/>

②	
strictly monotonic decreasing	<input type="checkbox"/>
concave down	<input type="checkbox"/>
strictly monotonic increasing	<input type="checkbox"/>

[0/1 point]

Task 18

Definite Integral

Below, a graph of a polynomial function f with zeros at $x_1 = -1$, $x_2 = 0$, $x_3 = 2$ and $x_4 = 4$ is pictured.

For the areas labelled as A_1 , A_2 and A_3 the following applies: $A_1 = 0.4$, $A_2 = 1.5$ and $A_3 = 3.2$.

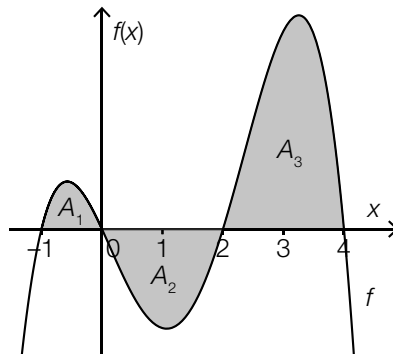

Task:

Put a cross next to each of the two equations that are true.

$\int_{-1}^2 f(x) dx = 1.9$	<input type="checkbox"/>
$\int_0^4 f(x) dx = 1.7$	<input type="checkbox"/>
$\int_{-1}^4 f(x) dx = 5.1$	<input type="checkbox"/>
$\int_0^2 f(x) dx = 1.5$	<input type="checkbox"/>
$\int_2^4 f(x) dx = 3.2$	<input type="checkbox"/>

[0/1 point]

Task 19

Histogram

A company has a total of 200 employees. The following table depicts the hourly wages of the employees in groups.

hourly wages x in Euro	number of employees
$6 \leq x < 10$	20
$10 \leq x < 15$	80
$15 \leq x < 20$	60
$20 \leq x \leq 30$	40

The area of the rectangle in the histogram below represents the relative proportion of the employees in each group.

Task:

Add the missing column to the given histogram so that the table is fully represented by the histogram.

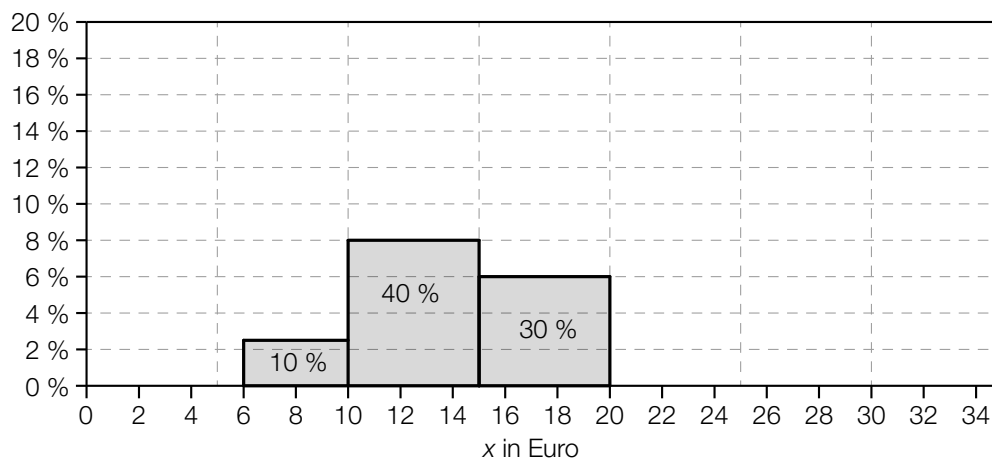

[0/1 point]

Task 20

Statistical Indicators

A data set is expanded by a value which is greater than all the values in the original set. Two of the following statistical indicators are certainly greater in the new set.

Task:

Put across next to each of the two appropriate statistical indicators.

span	<input type="checkbox"/>
modus	<input type="checkbox"/>
median	<input type="checkbox"/>
3 rd quartile	<input type="checkbox"/>
arithmetic mean	<input type="checkbox"/>

[0/1 point]

Task 21

Flu in Austria

The Medical University of Vienna has published the data on flu strain infections for a specific week. To compile this data, the blood of people, who were sick with the flu in this specific week was analysed. Of the 1 954 analysed samples, 547 blood samples were infected with the virus *A(H1N1)*, 117 blood samples were infected with the virus *A(H3N2)* and the rest of the blood samples were infected with the virus *Influenza B*.

Task:

Use the given frequencies as probabilities and given these criteria, determine the probability that a randomly selected infected person was infected with the Virus *Influenza B*.

[0/1 point]

Task 22

Basketball

Martin and Sebastian each once and one after another throw a ball in the direction of the hoop. Martin dunks (basketball falls through hoop) with a probability of 0.7 and Sebastian dunks with a probability of 0.8 (independent of Martin's success).

Task:

Calculate the probability that exactly one of the two players dunks.

[0/1 point]

Task 23

Three Tosses of a Cone

When tossing a cone, it can either land on its curved surface or on its base.

Independent from other tosses, the probability that a cone lands on its base is 30 %.

A cone gets tossed three times during a random experiment. The random variable X describes how often the cone lands on its base.

The table below should show the probability distribution of the random variable X .

Task:

Complete the missing values in the table.

X	probability (approximated)
0	0.343
1	0.441
2	
3	

[0/1 point]

Task 24

Breakfast

In a recent poll, 252 out of 450 questioned youths of a federal state stated that they always eat breakfast before going to school. The proportion of these youths is described by h .

The proportion of all youths in this federal state which always eat breakfast before heading to school is described by p .

Task:

Based on the results of the poll, write down the to h symmetrical 95-%-confidence interval for p .

[0/1 point]

Task 1

Relationship between Two Variables

For $a, b \in \mathbb{R}$ the relationship $a \cdot b = 1$ holds.

Task:

Two of the five following statements hold true in any case.

Put a cross next to each of the two correct statements.

If a is less than zero, then b is also less than zero.	<input type="checkbox"/>
The signs of a and b can be different.	<input type="checkbox"/>
For every $n \in \mathbb{N}$, $(a - n) \cdot (b + n) = 1$ holds.	<input type="checkbox"/>
For every $n \in \mathbb{N} \setminus \{0\}$, $(a \cdot n) \cdot \left(\frac{b}{n}\right) = 1$ holds.	<input type="checkbox"/>
$a \neq b$ holds.	<input type="checkbox"/>

Task 2

Solar Panel System

A town supports the installation of systems of solar panels in h households by providing p % of the purchase costs to each household. The mean value for the purchase costs for a system of solar panels in this town is e euros.

Task:

Interpret the expression $h \cdot e \cdot \frac{p}{100}$ in the given context.

Task 3

Number of Solutions to a Quadratic Equation

Let $r \cdot x^2 + s \cdot x + t = 0$ be a quadratic equation in the variable x with coefficients $r, s, t \in \mathbb{R} \setminus \{0\}$.

The number of real solutions to the equation depends on r, s and t .

Task:

Find the number of real solutions to the given equation if r and t have different signs and provide a general justification for your answer.

Task 4

Forces

Three forces act on a point mass M . These forces are represented by the vectors \vec{a} , \vec{b} and \vec{c} .

Task:

In the diagram below, draw a force vector \vec{d} such that the sum of all four forces is zero (for all components).

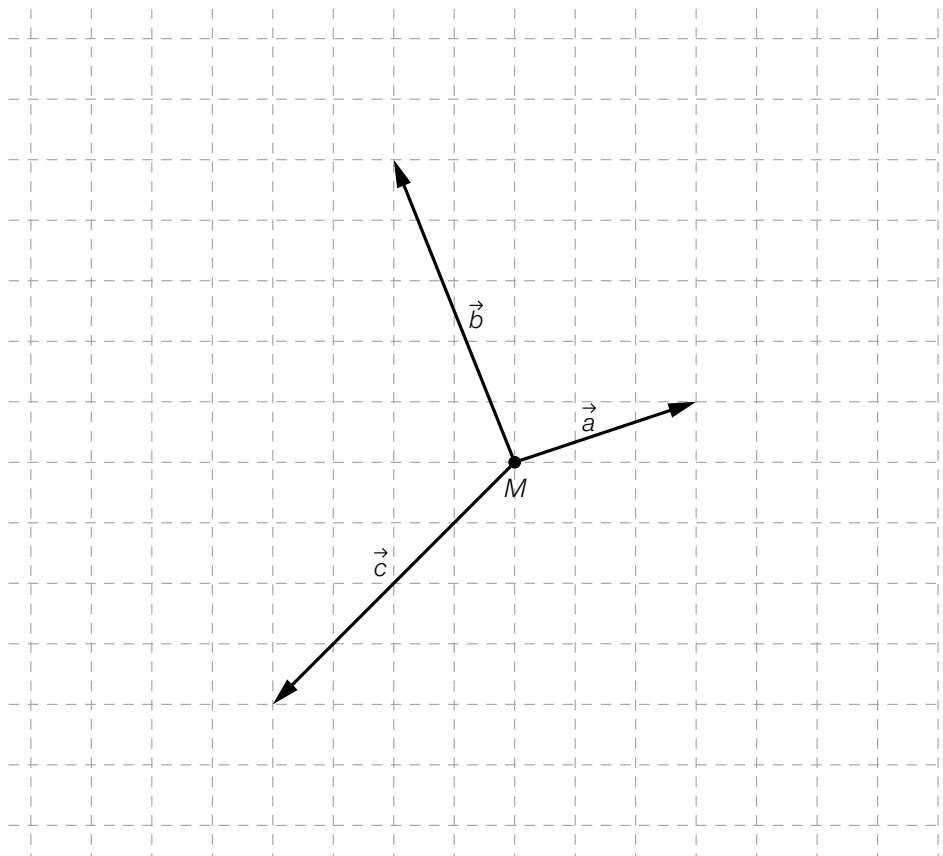

Task 5

Right Angle

Let AB be a line segment in \mathbb{R}^2 where $A = (3,4)$ and $B = (-2,1)$.

Task:

Write down a possible vector $\vec{n} \in \mathbb{R}^2$ where $\vec{n} \neq \begin{pmatrix} 0 \\ 0 \end{pmatrix}$ that is perpendicular to the line segment AB .

Task 6

Sine and Cosine

The diagram below shows a circle with centre O and radius 1. The points $A = (1,0)$ and P lie on the circumference of the circle. The angle α shown below is measured from the leg OA to the leg OP in a counterclockwise direction.

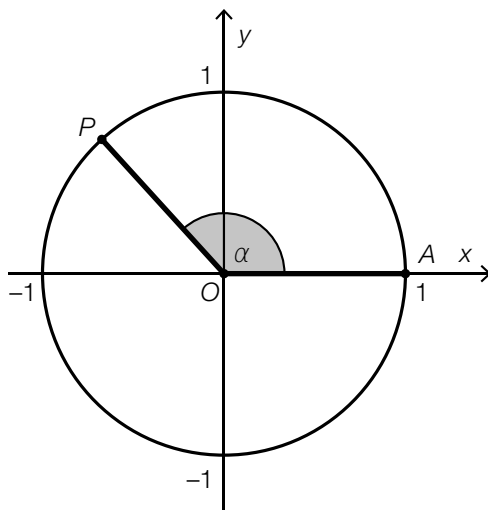

A point Q on the circumference of the circle should give rise to an angle β such that the following conditions hold:

$$\sin(\beta) = -\sin(\alpha) \text{ and } \cos(\beta) = \cos(\alpha)$$

Task:

Draw the point Q on the diagram above.

Task 7

Square Pyramid

The surface area of a regular square pyramid can be written as a function O of the length of the edge of the base a and the height of the lateral face h_1 .

The equation of the function is: $O(a, h_1) = a^2 + 2 \cdot a \cdot h_1$, where $a \in \mathbb{R}^+$ and $h_1 > \frac{a}{2}$.

Task:

Six statements about the surface area of regular square pyramids are given below. Put a cross next to the correct statement.

If h_1 is constant, then the surface area is directly proportional to a .	<input type="checkbox"/>
If a is constant, then the surface area is directly proportional to h_1 .	<input type="checkbox"/>
For $a = 1$ cm, the surface area is definitely greater than 2 cm^2 .	<input type="checkbox"/>
For $a = 1$ cm, the surface area is definitely less than 10 cm^2 .	<input type="checkbox"/>
If both a and h_1 are doubled, then the surface area is doubled.	<input type="checkbox"/>
If $h_1 = a^2$, then the surface area can be written as an exponential function in terms of a .	<input type="checkbox"/>

Task 8

Cyclists

Two cyclists A and B both start from the same starting point and cycle using electronic bicycles along a straight road in the same direction with constant speed.

The diagram below shows the graphs of the functions s_A and s_B , which show the distance covered by the cyclists with respect to the time spent cycling. The points shown in bold have coordinates $(0,0)$, $(2,0)$ and $(8,2400)$.

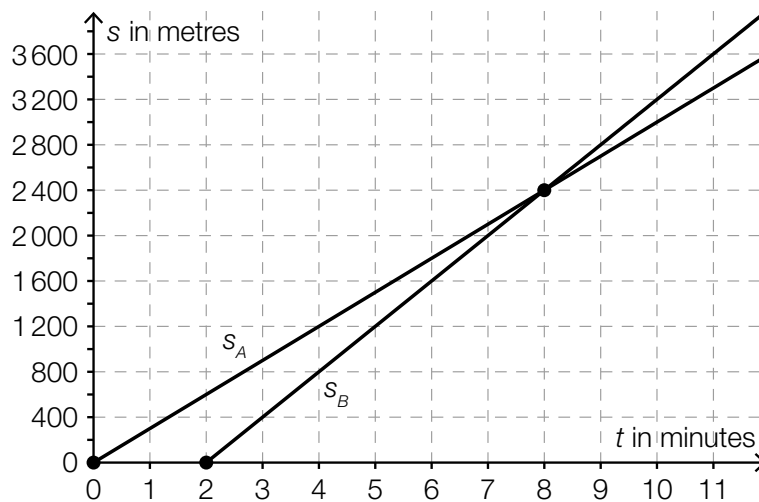

Task:

Put a cross next to each of the two statements that can be obtained from the diagram above.

Cyclist B starts two minutes later than cyclist A .	<input type="checkbox"/>
The speed of cyclist A is 200 metres per minute.	<input type="checkbox"/>
Cyclist B overtakes cyclist A after a distance of 2.4 kilometres.	<input type="checkbox"/>
Both cyclists are the same distance away from the starting point eight minutes after cyclist B has started.	<input type="checkbox"/>
Four minutes after cyclist A sets off, the two cyclists are 200 metres away from each other.	<input type="checkbox"/>

Task 9

Graphs of Quadratic Functions

The diagram below shows the graphs of the quadratic functions f_1 , f_2 and f_3 with equations $f_i(x) = a_i \cdot x^2 + b_i$ where $a_i, b_i \in \mathbb{R}, i \in \{1, 2, 3\}$.

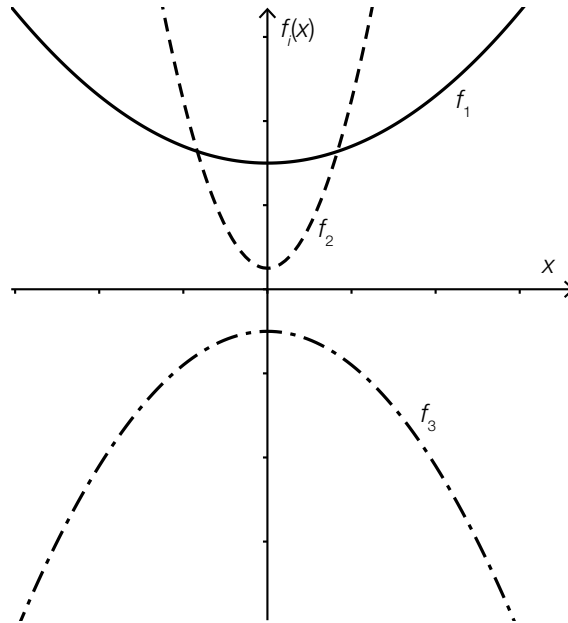

Task:

Write down the values of the parameters a_i and b_i in order from smallest to largest in the spaces provided below.

Parameter a_i : _____ < _____ < _____

Parameter b_i : _____ < _____ < _____

Task 10

Polynomial Function

The diagram below shows the graph of a polynomial function f .

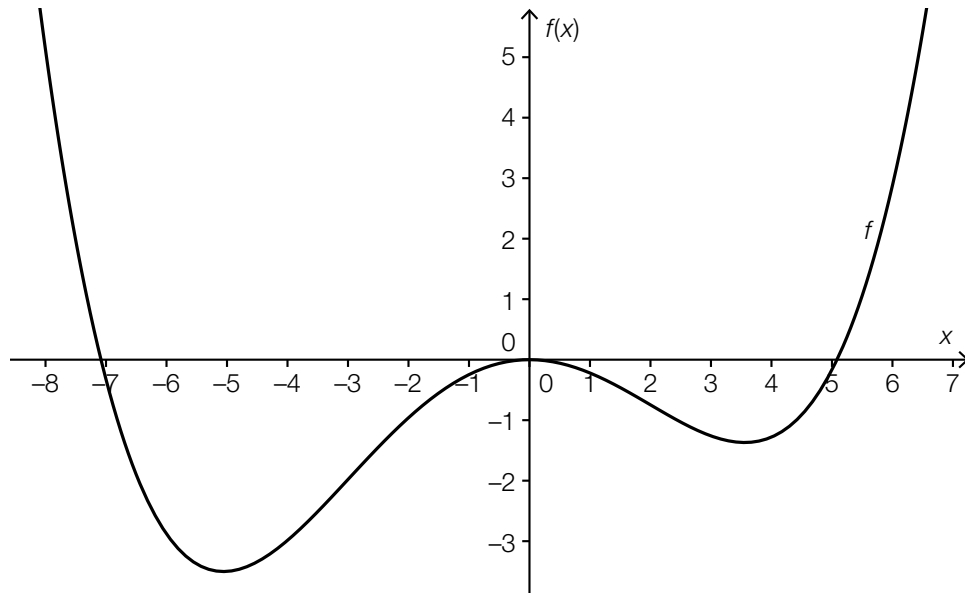

Task:

Justify why the function shown above cannot be a third degree polynomial function.

Task 11

Cell Cultures

In the context of a biological experiment, six cell cultures are placed under favourable or unfavourable external conditions such that the number of cells either increases exponentially or decreases exponentially.

The number of cells in each cell culture t days after the start of the experiment is given by $N_i(t)$ ($i = 1, 2, 3, 4, 5, 6$).

Task:

Match each of the four changes described below to the corresponding equation of a function (from A to F).

The number of cells doubles each day.	
The number of cells increases by 85 % each day.	
The number of cells decreases by 85 % each day.	
The number of cells decreases by half each day.	

A	$N_1(t) = N_1(0) \cdot 0.15^t$
B	$N_2(t) = N_2(0) \cdot 0.5^t$
C	$N_3(t) = N_3(0) \cdot 0.85^t$
D	$N_4(t) = N_4(0) \cdot 1.5^t$
E	$N_5(t) = N_5(0) \cdot 1.85^t$
F	$N_6(t) = N_6(0) \cdot 2^t$

Task 12

Sine Function

For $a, b \in \mathbb{R}^+$, let the function $f: \mathbb{R} \rightarrow \mathbb{R}$ be with $f(x) = a \cdot \sin(b \cdot x)$ for $x \in \mathbb{R}$.

The function f is known to have both of the properties given below:

- The (smallest) period of the function f is π .
- The difference between the largest and smallest value of the function f is 6.

Task:

Write down a and b .

$a =$ _____

$b =$ _____

Task 13

Value Added

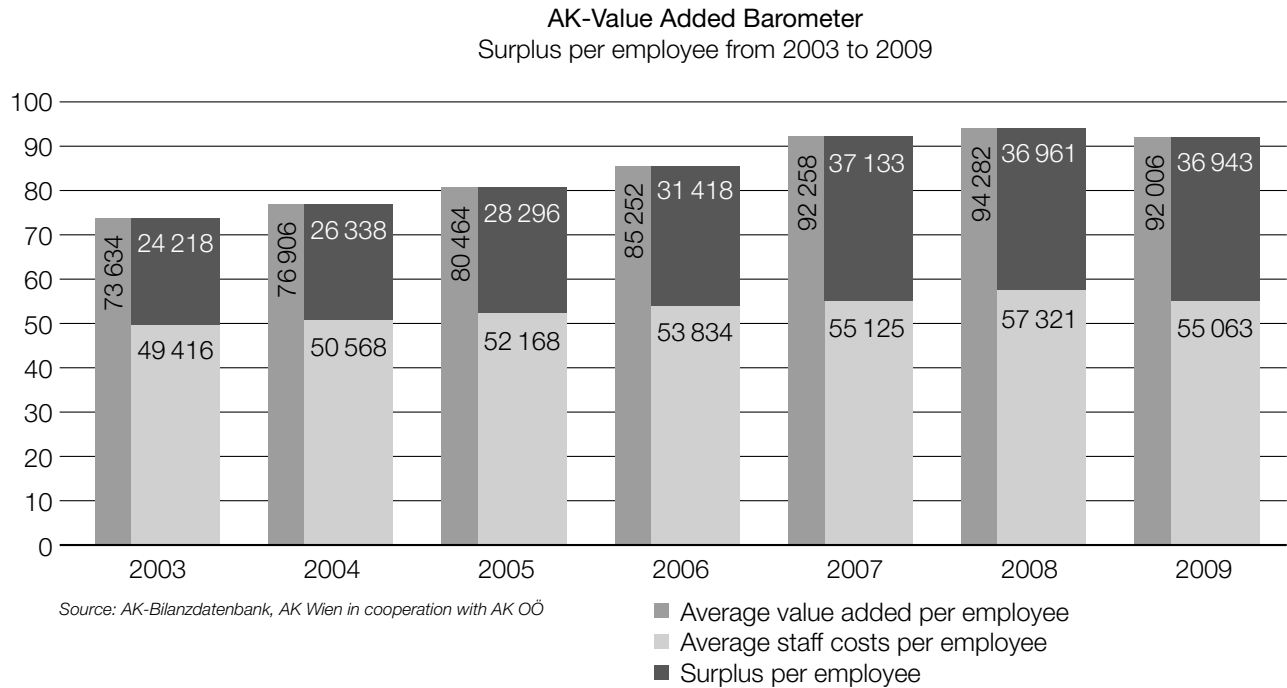

Data source: Arbeiterkammer Oberösterreich (ed.): *AK Wertschöpfungsbarometer: Trotz Krise: Eigentümer profitierten*, April 2011, p. 3. https://media.arbeiterkammer.at/ooe/betriebsraete/PKU_2011_Wertschoepfungsbarometer.pdf [12.09.2017].

The AK-Value Added Barometer shows the trend of the amount that Austrian medium-sized and large businesses earn on average for each employee per year.

The surplus per employee, i.e. the difference between the average value added per employee and the average staff costs per employee, is determined.

Task:

For the year 2007, determine the proportion of this surplus to the value added per head as a percentage.

Task 14

Cooling Process

A liquid is cooled. The function T can be used to approximate the temperature of the liquid, where $T(t)$ gives the temperature of the liquid at time $t \geq 0$ ($T(t)$ in $^{\circ}\text{C}$, t in minutes). The cooling process starts at time $t = 0$.

Task:

Interpret the equation $T'(20) = -0.97$ in the given context using the correct units.

Task 15

Debt Repayment

A person has taken out a bank loan to finance the purchase of an apartment. At the end of each month, the level of debt increases by 0.4 % due to the interest rate and a monthly instalment of € 450 is paid off the loan.

The level of debt at the end of t months is given by $S(t)$.

Task:

Write down a difference equation to help calculate, knowing the level of debt at the end of a month, the level of debt of the following month.

Task 16

Relationship between a Function, the Derivative and the Antiderivative

Let f be a third degree polynomial function with derivate f' and antiderivative F .

Task:

Complete the following sentence by putting a cross next to one of the given possibilities for each gap so that the sentence is a correct statement.

The second derivative of the function _____^①_____ is the function _____^②_____.

①	
f	<input type="checkbox"/>
f'	<input type="checkbox"/>
F	<input type="checkbox"/>

②	
f	<input type="checkbox"/>
f'	<input type="checkbox"/>
F	<input type="checkbox"/>

Task 17

Graph of a Function

A function $f: \mathbb{R} \rightarrow \mathbb{R}$ that is not constant has the following properties:

$$f(4) = 2$$

$$f'(4) = 0$$

$$f''(4) = 0$$

$$f'(x) \leq 0 \text{ for all } x \in \mathbb{R}$$

Task:

In the space provided below, sketch a possible graph of one such function f .

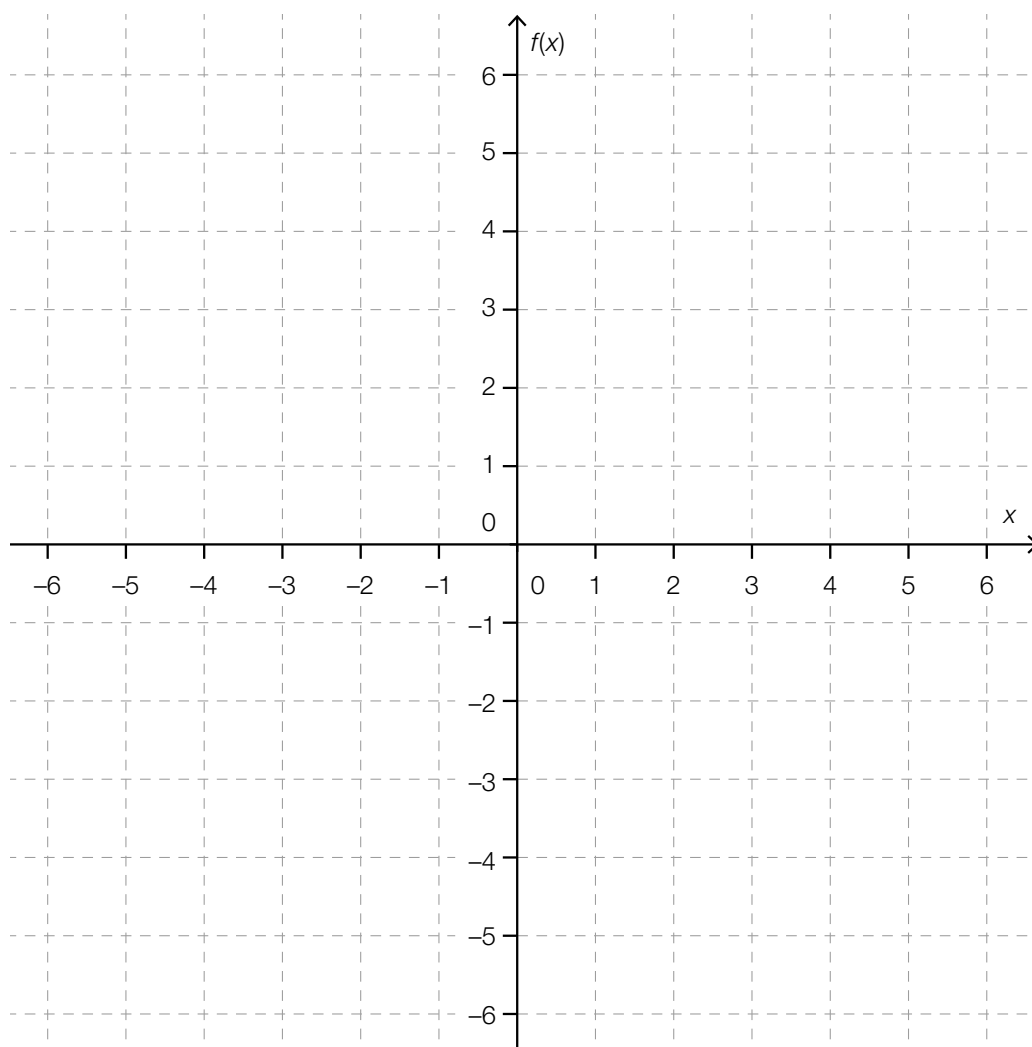

Task 18

Value of a Definite Integral

For a real function f the graph of an antiderivative F is shown below.

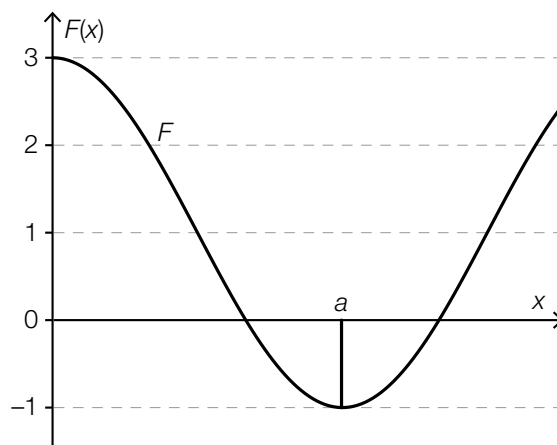

Task:

Write down the value of the definite integral $I = \int_0^a f(x) dx$.

$I =$ _____

Task 19

Homework and Examination

In a class of only girls, 15 pieces of homework were to be handed in before an examination. In the examination, a maximum of 48 points could be achieved.

In the scatter diagram shown below, the number of pieces of homework that were handed in and the number of points obtained in the examination are shown for each of the 20 pupils in this class.

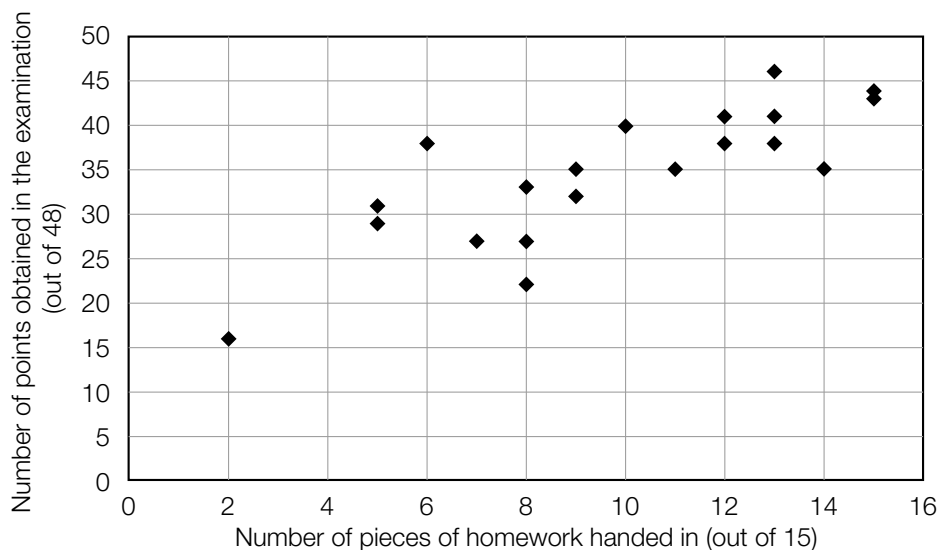

Task:

Two of the five statements shown below interpret the scatter diagram correctly. Put a cross next to each of the two correct statements.

Only pupils that handed in more than 10 pieces of homework were awarded more than 35 points on the examination.	<input type="checkbox"/>
The pupil with the lowest number of points on the examination had handed in the fewest pieces of homework.	<input type="checkbox"/>
The pupil with the highest number of points on the examination had handed in all of the pieces of homework.	<input type="checkbox"/>
Pupils who had handed in at least 10 pieces of homework achieved on average more points in the examination than those who had handed in fewer than 10 pieces of homework.	<input type="checkbox"/>
From the number of points awarded in the examination, it is possible to determine unequivocally the number of pieces of homework that had been handed in.	<input type="checkbox"/>

Task 20

Donations

For a good cause, 20 people have donated money. Each person has donated a different amount. These 20 amounts of money (in euros) comprise the data set x_1, x_2, \dots, x_{20} . From this data set, the minimum, the maximum, the mean, the median as well as the lower (first) and upper (third) quartiles can be determined.

Mrs. Müller is one of these 20 people and has donated 50 euros.

Task:

Each of the four questions in the table on the left-hand side can be answered correctly using one of the statistical values from the table on the right-hand side.

Match each of the four questions to the corresponding statistical value (from A to F).

Is Mrs. Müller's donation one of the five largest donations?	
Is Mrs. Müller's donation one of the ten largest donations?	
Is Mrs. Müller's donation the smallest donation?	
How many euros have the 20 people donated in total?	

A	Minimum
B	Maximum
C	Mean
D	Median
E	Lower quartile
F	Upper quartile

Task 21

Sweets

There are 50 sweets in a packet; 20 are red, 16 are white and 14 are green.

A child places their hand into the packet and takes out three sweets without looking at the colours.

Task:

Assuming that each sweet has an equal probability of being chosen, write down the probability that at least one of the three sweets is red.

Task 22

Comparing Two Probability Distributions

The diagrams below show the probability distributions of two random variables X and Y . The expectation values of the random variables are given by $E(X)$ and $E(Y)$ and the standard deviations are given by $\sigma(X)$ and $\sigma(Y)$.

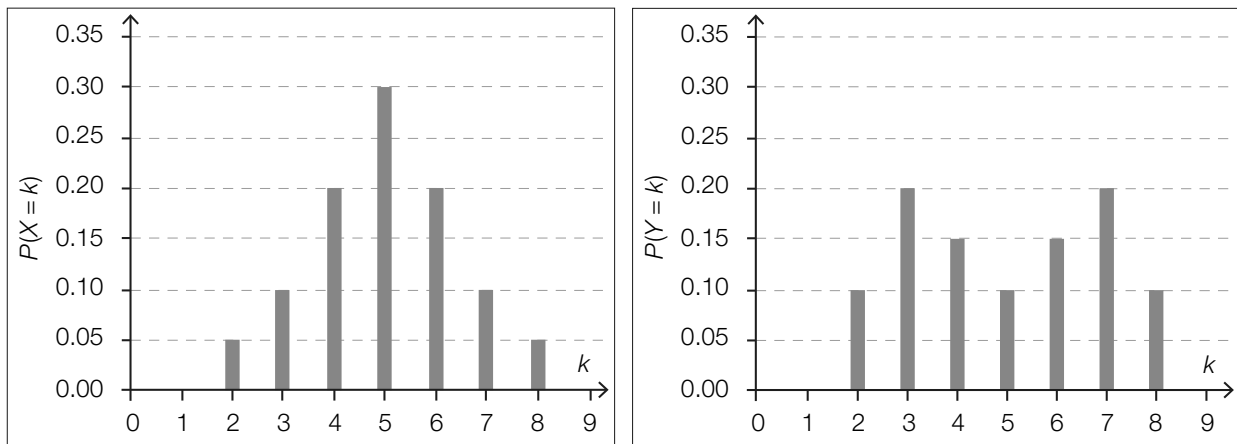

Task:

Put a cross next to each of the two correct statements.

$E(X) = E(Y)$	<input type="checkbox"/>
$\sigma(X) > \sigma(Y)$	<input type="checkbox"/>
$P(X \leq 3) < P(Y \leq 3)$	<input type="checkbox"/>
$P(3 \leq X \leq 7) = P(3 \leq Y \leq 7)$	<input type="checkbox"/>
$P(X \leq 5) = 0.3$	<input type="checkbox"/>

Task 23

Mass Production

A particular product is mass-produced in packs of 100 items. In a pack, the probability that an individual item (independent of the other items in the pack) is faulty is 6 %.

Task:

Determine the probability of the package containing at the most two faulty items.

Task 24

Widths of Confidence Intervals

Four confidence intervals (A , B , C and D) are calculated for an unknown proportion using the same method involving the sample size, n , the confidence level, γ , and the relative frequency. The relative frequency used for all four confidence intervals is the same. The confidence intervals are symmetrical about the relative frequency.

Confidence Interval	Sample Size n	Confidence Level γ
A	500	90 %
B	500	95 %
C	2000	90 %
D	2000	95 %

Task:

Compare the widths of these four confidence intervals and write down the confidence intervals with the smallest and the largest widths.

Confidence interval with the smallest width: _____

Confidence interval with the largest width: _____

Task 1

Sets of Numbers

Below you will see statements about numbers belonging to the sets \mathbb{Z} , \mathbb{Q} , \mathbb{R} and \mathbb{C} .

Task:

Put a cross next to each of the two true statements.

Irrational numbers can be written in the form $\frac{a}{b}$ with $a, b \in \mathbb{Z}$ and $b \neq 0$.	<input type="checkbox"/>
Every rational number can be written as a terminating or recurring number in its decimal representation.	<input type="checkbox"/>
Every fraction is a complex number.	<input type="checkbox"/>
The set of rational numbers comprises solely positive fractions.	<input type="checkbox"/>
Every real number is also a rational number.	<input type="checkbox"/>

Task 2

The Solution Set of a Quadratic Equation

A quadratic equation of the form $x^2 + a \cdot x = 0$ in x with $a \in \mathbb{R}$ is given.

Task:

Determine the value of a for which the equation given above has the solution set $\left\{0, \frac{6}{7}\right\}$.

$a =$ _____

Task 3

Gas Supplier

A household would like to change its gas provider and is deciding between supplier *A* and supplier *B*.

The energy content of the gas used is measured in kilowatt hours (kWh).

Supplier *A* charges an annual fixed fee of 340 euros and then 2.9 cents per kWh.

Supplier *B* charges an annual fixed fee of 400 euros and then 2.5 cents per kWh.

The inequality $0.025 \cdot x + 400 < 0.029 \cdot x + 340$ can be used to compare the expected costs of each supplier.

Task:

Determine the solution to the inequality given above and interpret the result in the given context.

Task 4

Sales Figures

A specialist sports shop offers n different sports products. The n sports products are arranged in a database according to their product number so that the list of amounts of each product can be written as a vector (with n components).

The vectors B , C and P (with $B, C, P \in \mathbb{R}^n$) are defined as follows:

Vector B : The component $b_i \in \mathbb{N}$ (with $1 \leq i \leq n$) gives the stock level of the i^{th} product on Monday morning of a particular week.

Vector C : The component $c_i \in \mathbb{N}$ (with $1 \leq i \leq n$) gives the stock level of the i^{th} product on Saturday evening of the same week.

Vector P : The component $p_i \in \mathbb{R}$ (with $1 \leq i \leq n$) gives the price per item (in euros) of the i^{th} product in this week.

During the week under consideration, the shop is open from Monday to Saturday, and over the course of the week no stock is delivered nor are the prices of the products changed.

Task:

At the end of the week, the data for the week under consideration (Monday to Saturday) is evaluated. The necessary calculations can be written as expressions. Match each of the four amounts to the corresponding expression (from A to F) that can be used to calculate the amount.

the average sales figures (per product) per day in the week	
the total income resulting from sales of sports products in the week	
the sales figures (per product) in the week	
the value of the remaining stock of sports products at the end of the week	

A	$6 \cdot (B - C)$
B	$B - C$
C	$\frac{1}{6} \cdot (B - C)$
D	$P \cdot C$
E	$P \cdot (B - C)$
F	$6 \cdot P \cdot (B - C)$

Task 5

Line Parallel to the x-Axis

Let g be a line with vector equation $g: X = \begin{pmatrix} 2 \\ 1 \end{pmatrix} + t \cdot \vec{a}$ with $t \in \mathbb{R}$.

Task:

Write down a vector $\vec{a} \in \mathbb{R}^2$ with $\vec{a} \neq \begin{pmatrix} 0 \\ 0 \end{pmatrix}$ such that the line g is parallel to the x-axis.

$\vec{a} =$ _____

Task 6

Right-Angled Triangle

The diagram below shows a right-angled triangle.

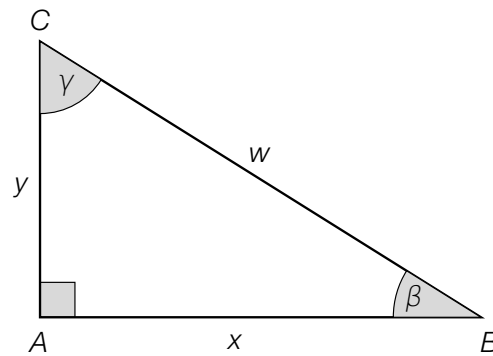

Task:

Write down an expression that can be used to determine the length of side w in terms of x and β .

$w =$ _____

Task 7

Solving a Quadratic Equation Graphically

The quadratic equation $x^2 + x - 2 = 0$ is given.

The equation shown above can be solved graphically using two functions f and g by considering the equation $f(x) = g(x)$.

Task:

The diagram below shows the graph of the quadratic function f where $f(x) \in \mathbb{Z}$ for each $x \in \mathbb{Z}$. Draw the graph of the function g in the diagram below.

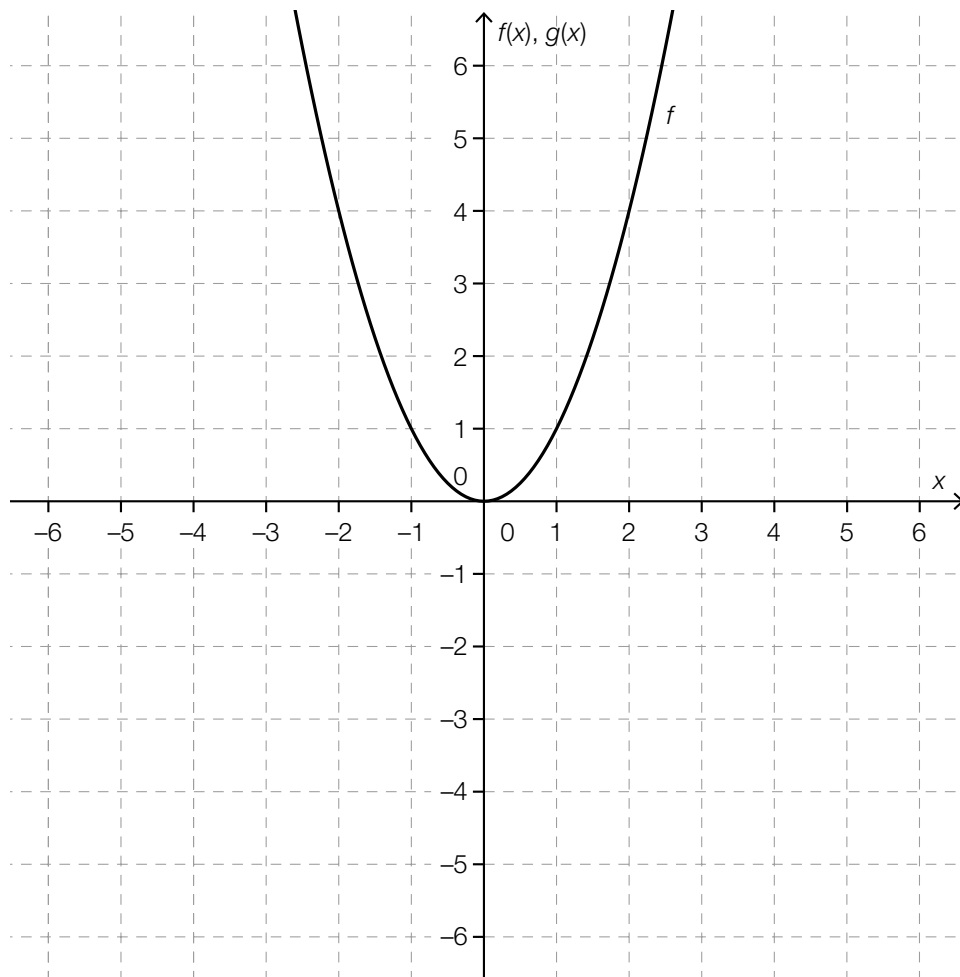

Task 8

Volume of a Cylinder

The volume of a cylinder can be given by a function V of the two quantities h and r . The height of the cylinder is given by h and the radius of the (circular) base is given by r .

Task:

Doubling the radius r and the height h of a cylinder, we obtain a cylinder whose volume will be x times as big as the volume of the original cylinder.

Determine x .

$x =$ _____

Task 9

Linear Relationships

In certain cases, relationships expressed verbally can be represented by linear functions.

Task:

Which of the following relationships can be described by a linear function? Put a cross next to each of the two correct relationships.

The cost of apartments increases annually by 10 % of the current value.	<input type="checkbox"/>
The area of a square piece of land increases as its side length increases.	<input type="checkbox"/>
The circumference of a circle increases as its radius increases.	<input type="checkbox"/>
The height of a 17 cm candle decreases after it has been lit by 8 mm per minute.	<input type="checkbox"/>
In a culture of bacteria, the number of bacteria doubles per hour.	<input type="checkbox"/>

Task 10

Properties of a Polynomial Function

Let $f: \mathbb{R} \rightarrow \mathbb{R}$ be a polynomial function with equation $f(x) = a \cdot x^3 + b \cdot x^2 + c \cdot x + d$ ($a, b, c, d \in \mathbb{R}, a \neq 0$).

Task:

Statements about the function f are given below.

Which of these statements is/are always true for arbitrary values of $a \neq 0, b, c$ and d ? Put a cross next to each correct statement.

The function f crosses the x -axis at least once.	<input type="checkbox"/>
The function f has at most two local maxima or minima.	<input type="checkbox"/>
The function f has at most two points in common with the x -axis.	<input type="checkbox"/>
The function f has exactly one point of inflexion.	<input type="checkbox"/>
The function f has at least one local maximum or minimum.	<input type="checkbox"/>

Task 11

Exponential Function

For an exponential function f with $f(x) = 5 \cdot e^{\lambda \cdot x}$ the following equation holds: $f(x + 1) = 2 \cdot f(x)$.

Task:

Write down the value of λ .

$\lambda =$ _____

Task 12

Half Life

The mass $m(t)$ of a radioactive substance can be written as an exponential function m in terms of the time t .

At the beginning of a measurement, there is 100 mg of the substance. After four hours only 75 mg of the substance remains.

Task:

Determine the half life $t_{\frac{1}{2}}$ of this radioactive substance in hours.

Task 13

Water Level of a River

The function $W: [0, 24] \rightarrow \mathbb{R}_0^+$ assigns each time t to the water level $W(t)$ of a particular river at a certain measuring site. Here, t is measured in hours and $W(t)$ in metres.

Task:

Interpret the expression given below in the context of the water level $W(t)$ of the river.

$$\lim_{\Delta t \rightarrow 0} \frac{W(6 + \Delta t) - W(6)}{\Delta t}$$

Task 14

Average Rate of Change

The following table of values for a function f is given below:

x	$f(x)$
-3	42
-2	24
-1	10
0	0
1	-6
2	-8
3	-6
4	0
5	10
6	24

Task:

The average rate of change of the function f is zero in the interval $[-1, b]$ for precisely one $b \in \{0, 1, 2, 3, 4, 5, 6\}$.

Determine b .

$b =$ _____

Task 15

Properties of an Antiderivative

The graph of a linear function g is shown in the diagram below.

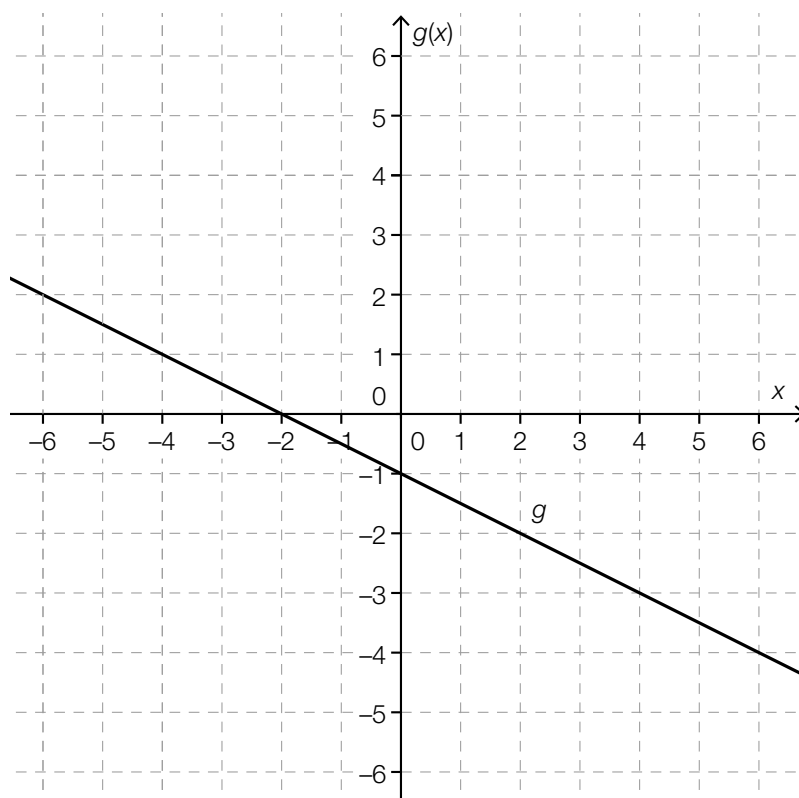

Task:

Put a cross next to each of the two statements that are true for the function g .

Every antiderivative of g is a second degree polynomial function.	<input type="checkbox"/>
Every antiderivative of g has a local minimum when $x = -2$.	<input type="checkbox"/>
Every antiderivative of g is strictly monotonically decreasing in the interval $(0, 2)$.	<input type="checkbox"/>
The function G with $G(x) = -0.5$ is an antiderivative of g .	<input type="checkbox"/>
Every antiderivative of g has at least one zero.	<input type="checkbox"/>

Task 16

Second Derivative

The graph of a third degree polynomial function f is shown below.

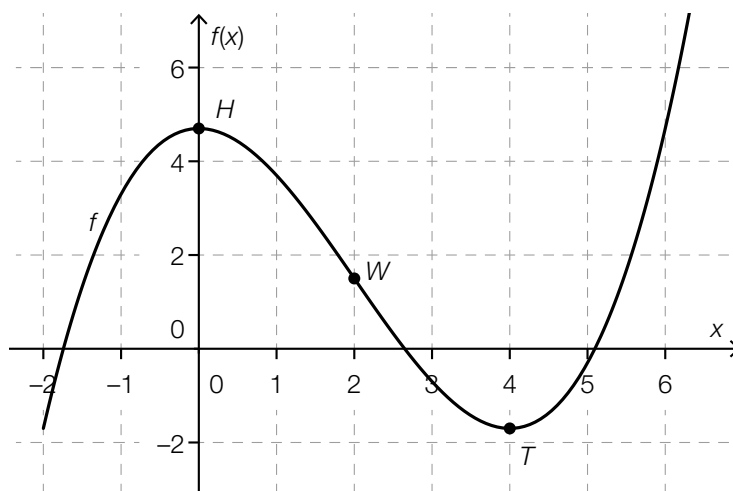

The points shown in bold are the maximum $H = (0, f(0))$, the point of inflexion $W = (2, f(2))$ and the minimum $T = (4, f(4))$ of the graph.

Task:

Five statements about the second derivative of f are given below.
Put a cross next to each of the two true statements.

For all x in the interval $[-1, 1]$, $f''(x) < 0$ holds.	<input type="checkbox"/>
For all x in the interval $[1, 3]$, $f''(x) < 0$ holds.	<input type="checkbox"/>
For all x in the interval $[3, 5]$, $f''(x) < 0$ holds.	<input type="checkbox"/>
$f''(0) = f''(4)$	<input type="checkbox"/>
$f''(2) = 0$	<input type="checkbox"/>

Task 17

Definite Integral

The diagram below shows the graph of a piecewise linear function f . The points A , B and C of the graph of the function have integer coordinates.

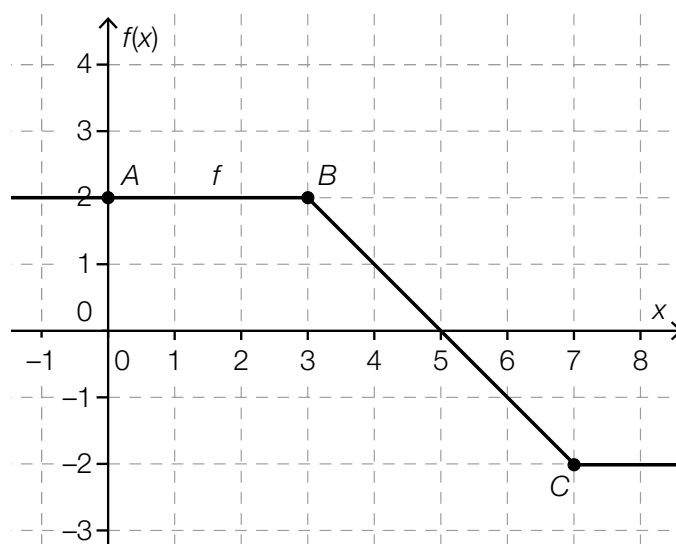

Task:

Determine the value of the definite integral $\int_0^7 f(x) dx$.

$$\int_0^7 f(x) dx = \underline{\hspace{10cm}}$$

Task 18

Acceleration

The function a gives the acceleration of a moving object in terms of the time t in the time interval $[t_1, t_1 + 4]$. The acceleration $a(t)$ is given in m/s^2 , and the time t is given in s.

It is known that:

$$\int_{t_1}^{t_1+4} a(t) dt = 2$$

Task:

One of the statements shown below interprets the given definite integral correctly. Put a cross next to the correct statement.

The object covers a distance of 2 m in the given time interval.	<input type="checkbox"/>
The velocity of the object at the end of the given time interval is 2 m/s.	<input type="checkbox"/>
The acceleration of the object at the end of the given time interval is 2 m/s^2 greater than it was at the beginning of the interval.	<input type="checkbox"/>
The velocity of the object increased by 2 m/s in this time interval.	<input type="checkbox"/>
On average, the velocity of the object increases by 2 m/s per second in the given time interval.	<input type="checkbox"/>
In the given time interval, the acceleration of the object increases by $\frac{2}{4} \text{ m/s}^2$ per second.	<input type="checkbox"/>

Task 19

Gross Domestic Product

The *nominal gross domestic product* (GDP) gives the total value of all goods produced within the borders of a country over a year at current market prices.

The *GDP per capita* is calculated by dividing the nominal gross domestic product of a country by the number of inhabitants.

The diagram below shows the relative change of the GDP per capita in Austria from 2012 in relation to 2002.

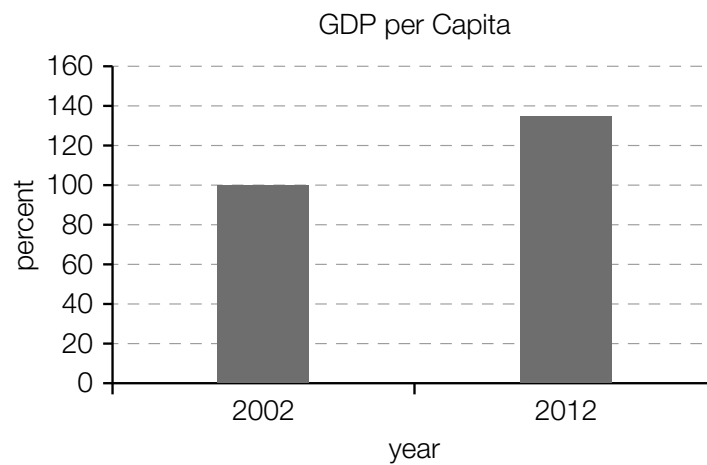

Task:

Write down whether the value of the relative change of the nominal gross domestic product in Austria from 2012 in relation to 2002 can be determined using solely the data given in the diagram shown above and justify your answer.

Task 20

Change in a List of Data

A list of data x_1, x_2, \dots, x_n with n values has a mean of a . Two extra values, x_{n+1} and x_{n+2} are added to the list. The mean of the new list of data, $x_1, x_2, \dots, x_n, x_{n+1}, x_{n+2}$ is also a .

Task:

Write down a relationship between x_{n+1} , x_{n+2} and a as a formula that holds in this case.

Task 21

Red-Green Colour-Blindness

One of the most well-known vision defects is red-green colour-blindness. If a person is affected by this condition, then this vision defect is always present from birth and does not become more or less pronounced over time. Worldwide, around 9 % of all men and 0.8 % of all women have this condition. The proportion of women in the world population is 50.5 %.

Task:

Determine the probability that a randomly selected person is red-green colour-blind.

Task 22

Number of Possibilities

A team has n players. The trainer chooses six players from the team on one day and eight players from the team on another day. The order in which the players are chosen is not relevant. In both cases the number of possibilities for the choice is the same.

Task:

Determine n (the number of players in this team).

$n =$ _____

Task 23

Binomial Distribution

The relative proportion of the Austrian population with the blood type “AB Rhesus Negative” (AB-) is known and is represented by p .

In a random sample of 100 people it is to be determined how many of these randomly selected people have this blood type.

Task:

Match each of the four events described below with the corresponding expression (from A to F) that gives the probability of this event occurring.

Exactly one person has the blood type AB-.	
At least one person has the blood type AB-.	
At most one person has the blood type AB-.	
None of the people has the blood type AB-.	

A	$1 - p^{100}$
B	$p \cdot (1 - p)^{99}$
C	$1 - (1 - p)^{100}$
D	$(1 - p)^{100}$
E	$p \cdot (1 - p)^{99} \cdot 100$
F	$(1 - p)^{100} + p \cdot (1 - p)^{99} \cdot 100$

Task 24

Reducing a Confidence Interval

A company that produces toys conducts a survey of 500 randomly selected households in a town and determines a 95 % confidence interval for the unknown proportion of all households in this town that have heard of the toys made by this company.

A second survey of n randomly selected households resulted in the same value for the relative frequency. Using the same method of calculation, the 95 % confidence interval determined from this survey was less wide than the interval from the first survey.

Task:

Write down all $n \in \mathbb{N}$ for which this case would occur under the specified condition.

Task 1

Numbers and Sets of Numbers

Below you will see statements about numbers and sets of numbers.

Task:

Put a cross next to each of the two true statements.

There exists at least one number which is contained in \mathbb{N} , but not in \mathbb{Z} .	<input type="checkbox"/>
$-\sqrt{9}$ is an irrational number.	<input type="checkbox"/>
The number 3 is an element of the set \mathbb{Q} .	<input type="checkbox"/>
$\sqrt{-2}$ is contained in \mathbb{C} , but not in \mathbb{R} .	<input type="checkbox"/>
The recurring number $1.\dot{5}$ is contained in \mathbb{R} , but not in \mathbb{Q} .	<input type="checkbox"/>

Task 2

Representing Relationships as Equations

Many relationships can be expressed mathematically as equations.

Task:

Match each of the four descriptions of a possible relationship between two numbers a and b , where $a, b \in \mathbb{R}^+$, with the corresponding equation (from A to F).

a is half as big as b .	
b is 2 % of a .	
a is 2 % bigger than b .	
b is 2 % smaller than a .	

A	$2 \cdot a = b$
B	$2 \cdot b = a$
C	$a = 1.02 \cdot b$
D	$b = 0.02 \cdot a$
E	$1.2 \cdot b = a$
F	$b = 0.98 \cdot a$

Task 3

System of Equations

Below you will see a system of two linear equations involving the variables $x, y \in \mathbb{R}$.

$$\text{I: } a \cdot x + y = -2 \text{ where } a \in \mathbb{R}$$

$$\text{II: } 3 \cdot x + b \cdot y = 6 \text{ where } b \in \mathbb{R}$$

Task:

Determine the coefficients a and b such that the system of equations has infinitely many solutions.

$$a = \underline{\hspace{10cm}}$$

$$b = \underline{\hspace{10cm}}$$

Task 4

Parallel Lines

Let g and h be lines with vector equations $g: X = P + t \cdot \vec{u}$ and $h: X = Q + s \cdot \vec{v}$ where $s, t \in \mathbb{R}$ and $\vec{u}, \vec{v} \neq \begin{pmatrix} 0 \\ 0 \end{pmatrix}$.

Task:

Assuming that the two lines are parallel to each other but not identical, which of the following statements are definitely true?

Put a cross next to each of the two true statements.

$P = Q$	<input type="checkbox"/>
$P \in h$	<input type="checkbox"/>
$Q \notin g$	<input type="checkbox"/>
$\vec{u} \cdot \vec{v} = 0$	<input type="checkbox"/>
$\vec{u} = a \cdot \vec{v}$ where $a \in \mathbb{R} \setminus \{0\}$	<input type="checkbox"/>

Task 5

Relationship between Vectors

Let \vec{a} and \vec{b} be two vectors with $\vec{a} = \begin{pmatrix} 13 \\ 5 \end{pmatrix}$ and $\vec{b} = \begin{pmatrix} 10 \cdot m \\ n \end{pmatrix}$ where $m, n \in \mathbb{R} \setminus \{0\}$.

Task:

The vectors \vec{a} and \vec{b} will be perpendicular to each other. Write down an expression for n in terms of m that holds in this case.

$n =$ _____

Task 6

Quadrilateral

Given is the following quadrilateral with side lengths a , b , c and d .

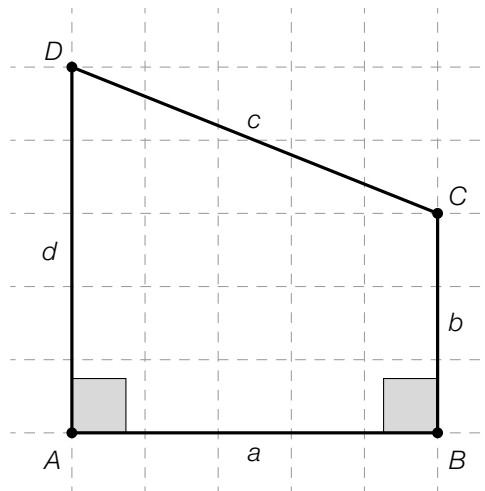

Task:

Draw the angle φ on the diagram above such that $\sin(\varphi) = \frac{d-b}{c}$ holds.

Task 7

Properties of Graphs of Functions

Properties of functions and characteristic sections of graphs are shown below.

Task:

Match each of the four properties to the corresponding graph (from A to F).

The function is monotonically increasing on its whole domain.	
The function is concave down on its whole domain.	
The function is concave up on the interval $(-\infty, 0)$.	
The function is monotonically decreasing on the interval $(-\infty, 0)$.	

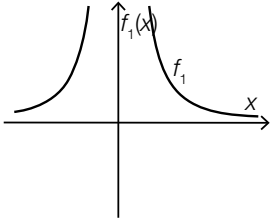
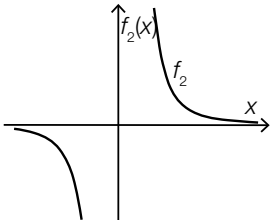
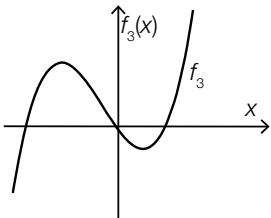
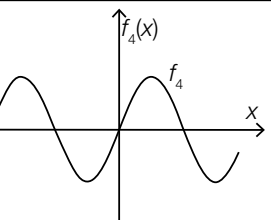
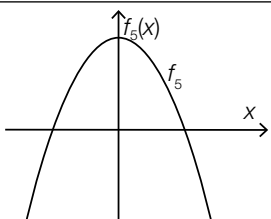
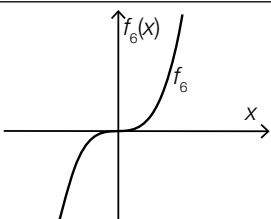
A	
B	
C	
D	
E	
F	

Task 8

Costs and Revenue

The cost function K of a product with $K(x) = 2 \cdot x + 4000$ and the revenue function E with $E(x) = 10 \cdot x$ are known. Here, x is the number of units of quantity produced and all units that are produced are sold as well. Costs and revenue are both given in euros.

The point of intersection of the two graphs is $S = (500|5000)$.

Task:

Interpret the coordinates 500 and 5000 of the point of intersection S in the given context.

Task 9

Interpreting an Equation

A balloon filled with helium ascends vertically. The balloon's height above a flat surface can be expressed as a linear function h in terms of the time t . The height $h(t)$ is measured in meters, the time t is measured in seconds.

Task:

Interpret the equation $h(t + 1) - h(t) = 2$ in the given context using the correct units.

Task 10

Third Degree Polynomial Functions

A third degree polynomial function can change its monotonicity at up to two points.

Task:

In the coordinate system given below, sketch the graph of a third degree polynomial function f that changes its monotonicity when $x = -3$ and $x = 1$.

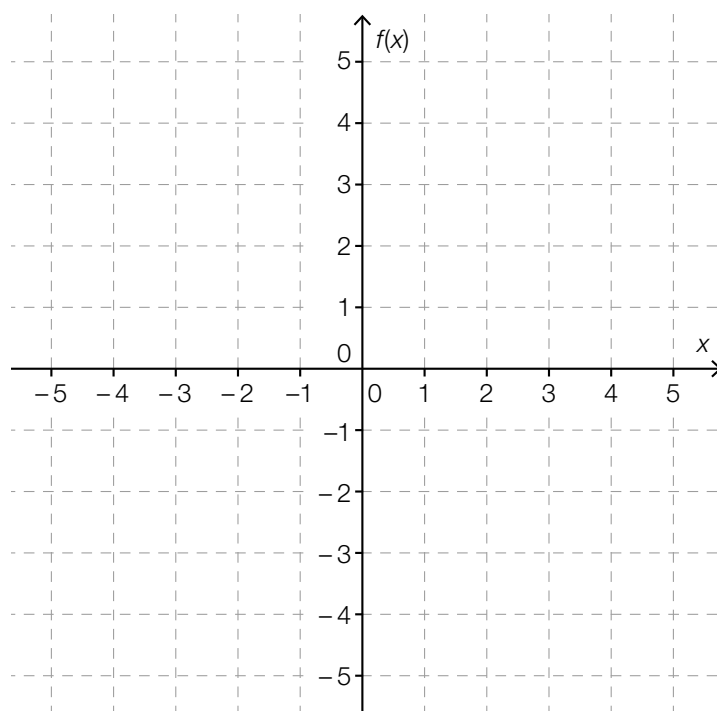

Task 11

Thickness of a Lead Plate

X-rays are used in the field of medical technology. To protect people against radiation, lead plates are installed. It is assumed that per 1 mm thickness of the lead plate, the intensity of the X-rays decreases by 5 %.

Task:

Calculate the thickness x (in mm) of the lead plate necessary to decrease the intensity of radiation to 10 % of the original intensity, with which the rays hit the lead plate.

Task 12

Trigonometric Functions

The diagram below shows the graphs of the functions f and g with equations $f(x) = \sin(x)$ and $g(x) = \cos(x)$.

For the points a and b , shown in the diagram, the following equation holds: $\cos(a) = \sin(b)$.

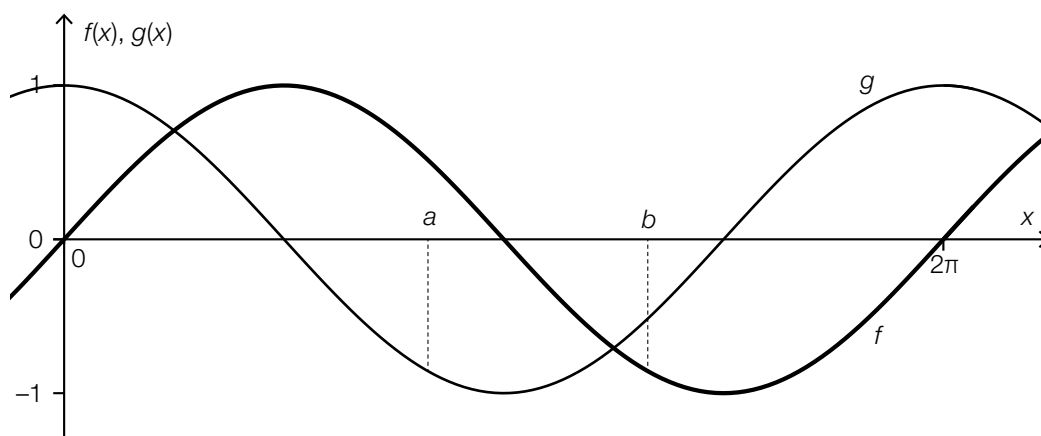

Task:

Determine $k \in \mathbb{R}$ such that $b - a = k \cdot \pi$ holds.

Task 13

Overnight Stays in Austrian Youth Hostels

The value N_{12} represents the number of overnight stays in Austrian youth hostels in the year 2012, whereas the value N_{13} represents the number of overnight stays in the year 2013.

Task:

Write down the meaning of the equation $\frac{N_{13}}{N_{12}} = 1.012$ with respect to the change of the number of overnight stays in Austrian youth hostels.

Task 14

Change of the Volume of a Liquid

The volume V of a liquid in a container changes over time t in the time interval $[t_0, t_4]$.

The diagram below shows the graph of the function V' , which gives the instantaneous rate of change of the volume of the liquid in the container in the given time interval.

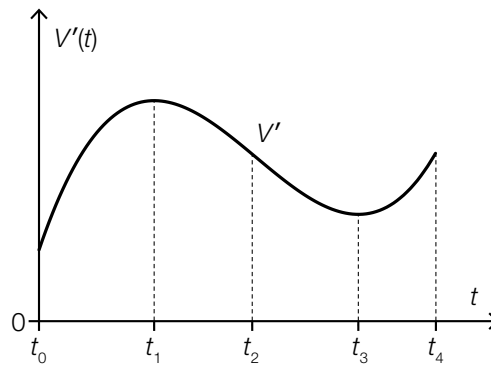

Task:

Put a cross next to each of the two true statements.

The volume of the liquid in the container decreases in the time interval $[t_1, t_3]$.	<input type="checkbox"/>
The volume of the liquid in the container is smaller at time t_2 than at time t_3 .	<input type="checkbox"/>
The instantaneous rate of change of the volume of the liquid in the container is lowest at time t_3 .	<input type="checkbox"/>
The volume of the liquid in the container is greatest at time t_4 .	<input type="checkbox"/>
The volume of the liquid in the container at time t_2 is the same as at time t_4 .	<input type="checkbox"/>

Task 15

Relationship between Function and Antiderivatives

The functions g and h are different antiderivatives of a polynomial function f of degree $n \geq 1$.

Task:

Put a cross next to each of the two true statements.

$g'(x) = h'(x)$	<input type="checkbox"/>
$g(x) + h(x) = c, c \in \mathbb{R} \setminus \{0\}$	<input type="checkbox"/>
$\int_0^2 g(x) dx = f(2) - f(0)$	<input type="checkbox"/>
$\int_0^2 f(x) dx = h(2) - h(0)$	<input type="checkbox"/>
$g(x) = c \cdot h(x), c \in \mathbb{R} \setminus \{1\}$	<input type="checkbox"/>

Task 16

Properties of a Third Degree Polynomial Function

The graph of a third degree polynomial function f is shown below. The points $x = -2$ and $x = 2$ are local maxima or minima of f .

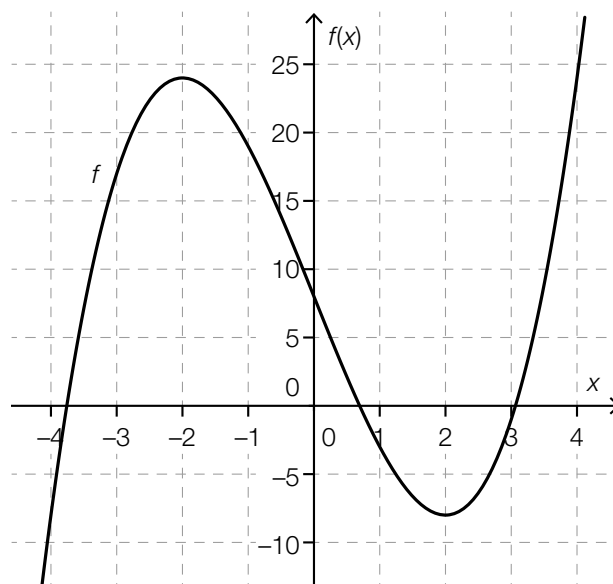

Task:

Put a cross next to each of the two true statements.

$f'(0) = 0$	<input type="checkbox"/>
$f''(1) > 0$	<input type="checkbox"/>
$f'(-3) < 0$	<input type="checkbox"/>
$f'(2) = 0$	<input type="checkbox"/>
$f''(-2) > 0$	<input type="checkbox"/>

Task 17

Lower Sum and Upper Sum

The diagrams below each show the graph of a function f , as well as one lower sum U (= sum of the areas of the rectangles marked in dark grey with the same width) and one upper sum O (= sum of the areas of the rectangles marked in light and dark grey with the same width) in the interval $[-a, a]$.

Task:

For two of the functions shown below, the condition $\int_{-a}^a f(x) dx = \frac{O+U}{2}$ holds true for constant rectangle width in the interval $[-a, a]$.

Put a cross next to each of the two diagrams for which the given condition is fulfilled.

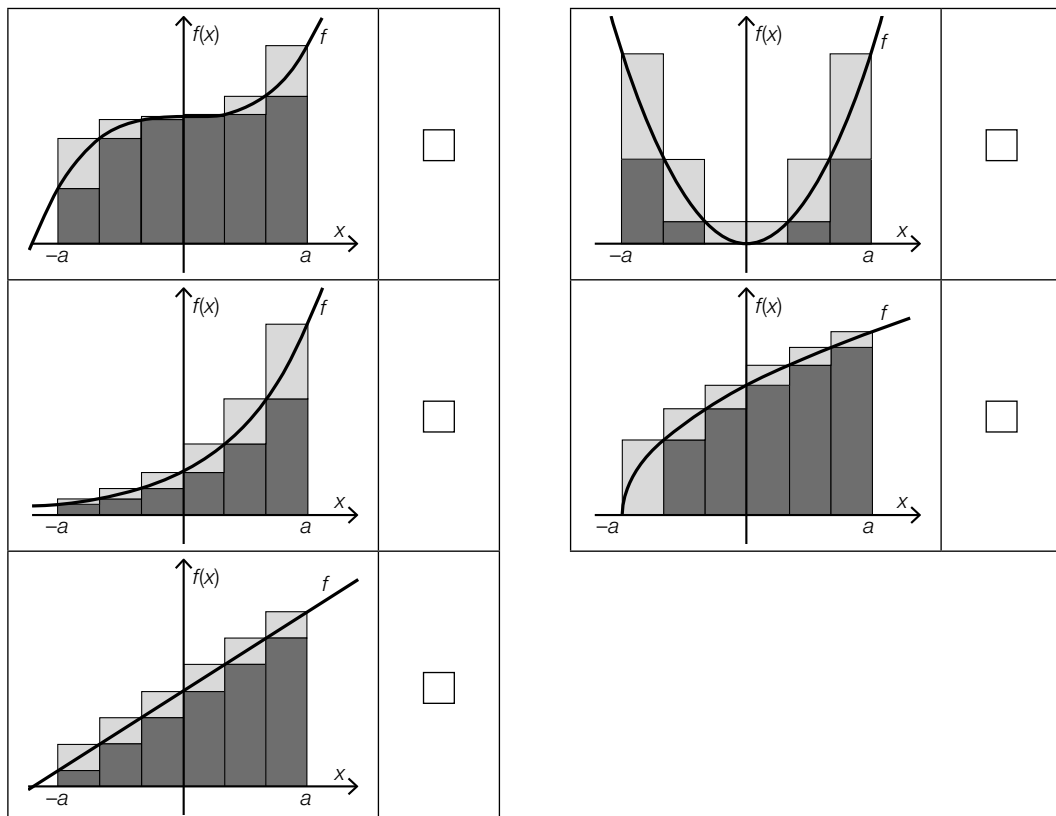

Task 18

Value of a Definite Integral

The diagram below shows the graph of a function $f: \mathbb{R} \rightarrow \mathbb{R}$. In addition, two areas have been shaded.

The region A_1 is enclosed by the graph of the function f and the x -axis in the interval $[0, 4]$ and has an area of $\frac{16}{3}$ units of area.

The region A_2 is enclosed by the graph of the function f and the x -axis in the interval $[4, 6]$ and has an area of $\frac{7}{3}$ units of area.

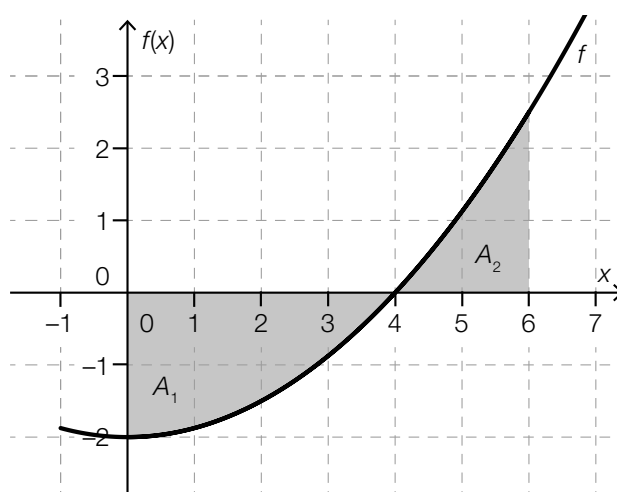

Task:

Write down the value of the definite integral $\int_0^6 f(x) dx$.

$$\int_0^6 f(x) dx = \underline{\hspace{2cm}}$$

Task 19

Persons in Employment

The diagram below shows the number of persons in employment in Austria in 2012 across three sectors. The diagram shows the data broken down by Austrian province.

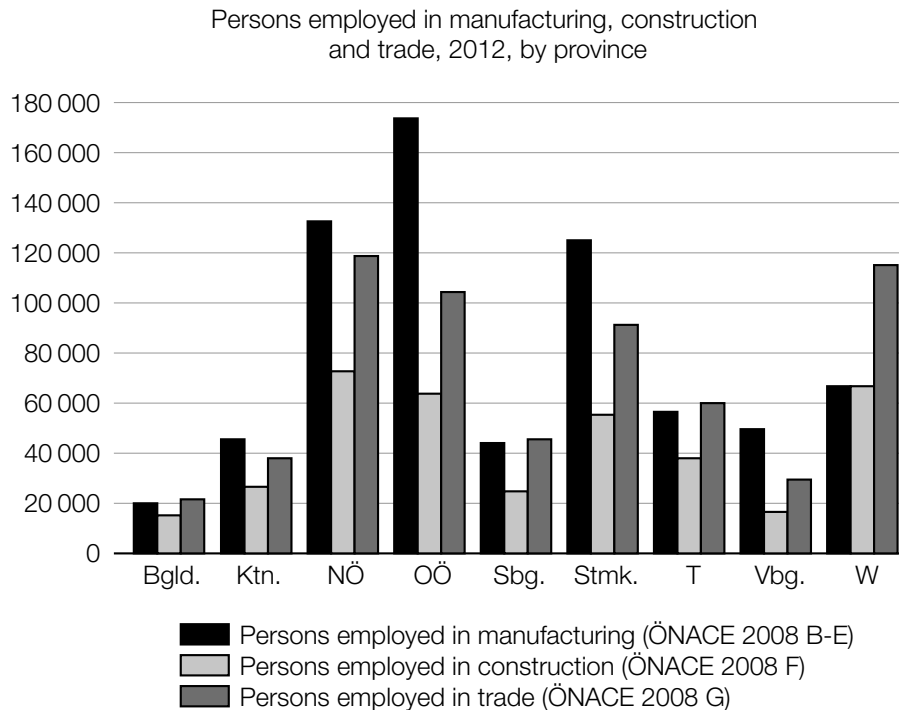

Source: STATISTIK AUSTRIA, Mikrozensus-Arbeitskräfteerhebung 2012. Created on 22.05.2013.

Task:

Which of the following statements about the year 2012 can be deduced from the diagram?
Put a cross next to each correct statement.

In every province, there were more persons employed in trade than in construction.	<input type="checkbox"/>
There were more persons employed in manufacturing in Upper Austria (OÖ) than in any other province.	<input type="checkbox"/>
In Vienna (W), there were more persons employed in trade than in manufacturing and construction combined.	<input type="checkbox"/>
In Vorarlberg (Vbg.), there were fewer persons employed in all three sectors combined than in manufacturing in Styria (Stmk.)	<input type="checkbox"/>
There were fewer persons employed in trade in Burgenland (Bgld.) than in any other province.	<input type="checkbox"/>

Task 20

Median Class Size

The following information on class sizes was collected from 24 classes from the lower cycle of a secondary school, i. e. the first four years of secondary school.

class size	20	21	22	23	24	25	26	27	28
number of classes	1	2	1	2	3	2	4	6	3

Task:

Determine the median value of the class sizes in the lower cycle of this secondary school.

Task 21

Gaming Chips

Inside two boxes, there are gaming chips.

Inside box I there are five 2-euro chips and two 1-euro chips.

Inside box II there are four 2-euro chips and five 1-euro chips.

One chip is drawn independently from each of the boxes. For each box, the probability to be drawn is the same for each chip.

Task:

Determine the probability that the same amount of money is left in each box after both chips have been drawn.

Task 22

Computer Chips

A company produces computer chips. Independent of each other, the probability that any of the computer chips produced is fully functioning is 97 %.

On one particular day, the company produces 500 computer chips.

Task:

Determine the expectation value and the standard deviation for the number of fully functioning computer chips that are produced on this day.

Expectation value: _____

Standard deviation: _____

Task 23

Returnable Bottles

The rate of return of the returnable bottles of a specific brand of mineral water is 92 %.

During one month, 15 000 returnable bottles of this brand of mineral water are sold. The random variable X gives the number of returnable bottles that are not returned. The random variable X can be approximated by a normal distribution.

The following diagram shows the graph of the density function f of this normal distribution. The area of the shaded section is around 0.27.

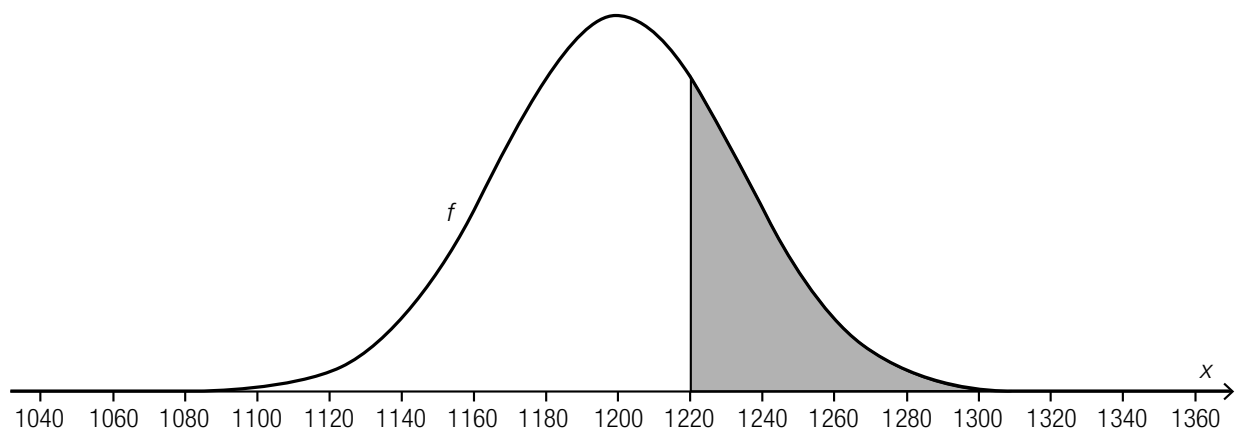

Task:

Interpret the meaning of the value 0.27 in the given context.

Task 24

Telephone Survey

In a representative telephone survey among 400 randomly selected people the value 20 % is obtained for the relative frequency of supporters of shorter summer holidays.

Task:

Demonstrate by means of calculation that the interval [16.0 %, 24.0 %] can be a symmetrical 95 % confidence interval for the relative frequency p of supporters in the whole population (where the values for the interval boundaries of the confidence interval are rounded).

Task 1

Integers

Let a be a positive integer.

Task:

Which of the following expressions for $a \in \mathbb{Z}^+$ always result in an integer?

Put a cross next to each of the two correct expressions.

a^{-1}	<input type="checkbox"/>
a^2	<input type="checkbox"/>
$a^{\frac{1}{2}}$	<input type="checkbox"/>
$3 \cdot a$	<input type="checkbox"/>
$\frac{a}{2}$	<input type="checkbox"/>

Task 2

Investment

An annual interest rate of 1.2 % is paid on an investment K for 5 years.

Task:

The following expression is given:

$$K \cdot 1.012^5 - K$$

Write down the meaning of this expression in the given context.

Task 3

Animal Feed

A farmer has bought two types of pre-prepared animal feed for his cattle.

Feed A has a protein content of 14 %, whereas feed B has a protein content of 35 %.

The farmer would like to create 100 kg of mixed feed for his male calves by mixing the two types of pre-prepared feeds. The resulting feed should have a protein content of 18 %. The mixture will contain a kg of feed A and b kg of feed B .

Task:

Write down two equations in terms of the variables a and b that can be used to calculate the necessary amounts for the mixture.

1st equation: _____

2nd equation: _____

Task 4

Cuboid with a Square Base

The diagram below shows a cuboid whose square base lies in the xy -plane. The length of an edge of the base is 5 units; the height of the solid is 10 units. The vertex D is located at the origin, and the vertex C lies on the positive y -axis.

Thus the vertex E has coordinates $E = (5,0,10)$.

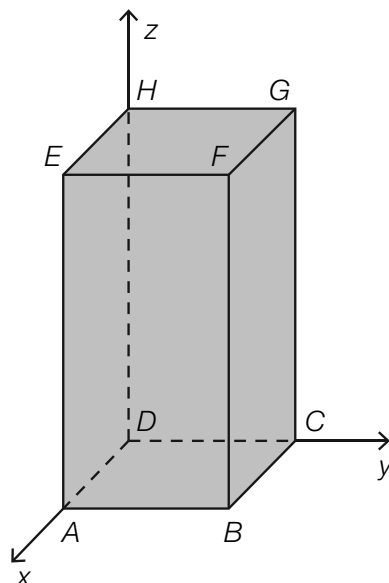

Task:

Determine the coordinates (components) of the vector \vec{HB} .

Task 5

Parallel Lines

Let g and h be lines with vector equations:

$$g: X = \begin{pmatrix} 1 \\ 1 \\ 1 \end{pmatrix} + t \cdot \begin{pmatrix} -3 \\ 1 \\ 2 \end{pmatrix} \text{ where } t \in \mathbb{R}$$

$$h: X = \begin{pmatrix} 3 \\ 1 \\ 1 \end{pmatrix} + s \cdot \begin{pmatrix} 6 \\ h_y \\ h_z \end{pmatrix} \text{ where } s \in \mathbb{R}$$

Task:

Determine the components h_y and h_z of the direction vector of line h such that line h is parallel to line g .

Task 6

Coordinates of a Point

In the diagram below the point $P = (-3, -2)$ is shown.

The location of the point P can also be uniquely determined by the distance $r = \overline{OP}$ and the size of the angle φ .

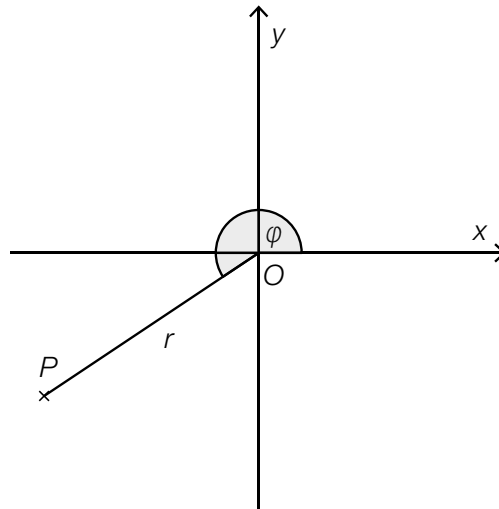

Task:

Determine the size of the angle φ .

Task 7

Volume of a Cylinder

The base of a cylinder has radius r and the height of the cylinder is given by h . If the height of the cylinder is constant, then the function V where $V(r) = r^2 \cdot \pi \cdot h$ describes the volume of the cylinder with respect to the radius.

Task:

The point $P = (r_1, V(r_1))$ is shown in the coordinate system given below. Plot the point $Q = (3 \cdot r_1, V(3 \cdot r_1))$ in the coordinate system.

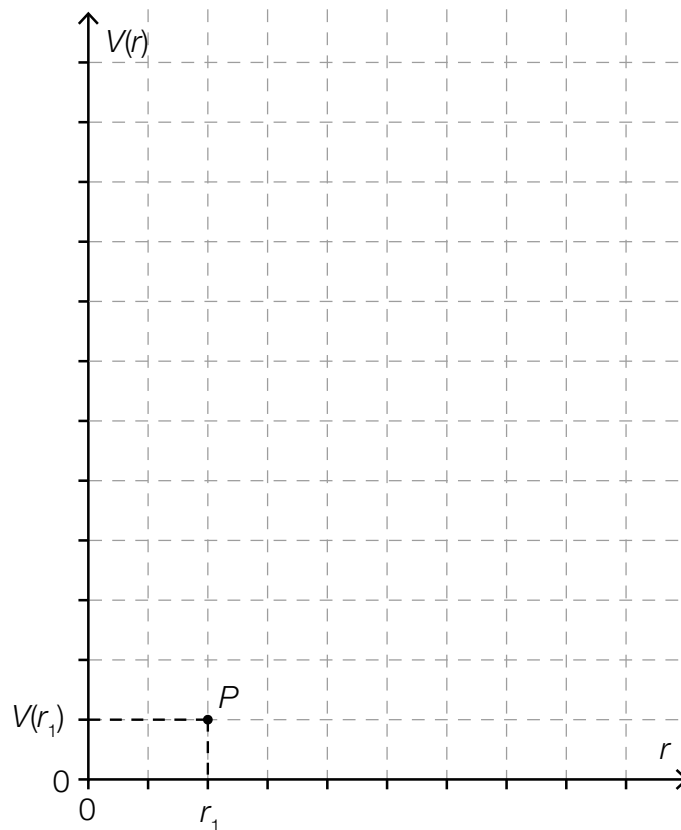

Task 8

Concavity of a Polynomial Function

The graph of a third degree polynomial function has a local minimum at point $T = (-3, 1)$, a local maximum at point $H = (-1, 3)$ and a point of inflexion at point $W = (-2, 2)$.

Task:

In which interval is the function concave up?

Put a cross next to the correct interval.

$(-\infty, 2)$	<input type="checkbox"/>
$(-\infty, -2)$	<input type="checkbox"/>
$(-3, -1)$	<input type="checkbox"/>
$(-2, 2)$	<input type="checkbox"/>
$(-2, \infty)$	<input type="checkbox"/>
$(3, \infty)$	<input type="checkbox"/>

Task 9

Predator-Prey Model

The predator-prey model gives a simplified model of population fluctuations of a predator group (e. g. the number of Canadian lynxes) and a prey group (e. g. the number of snowshoe hares). The functions R and B shown in the diagram below model the number of predators $R(t)$ and the number of prey animals $B(t)$ for an observed period of 24 years ($B(t)$, $R(t)$ are given in 10,000 individuals, t in years).

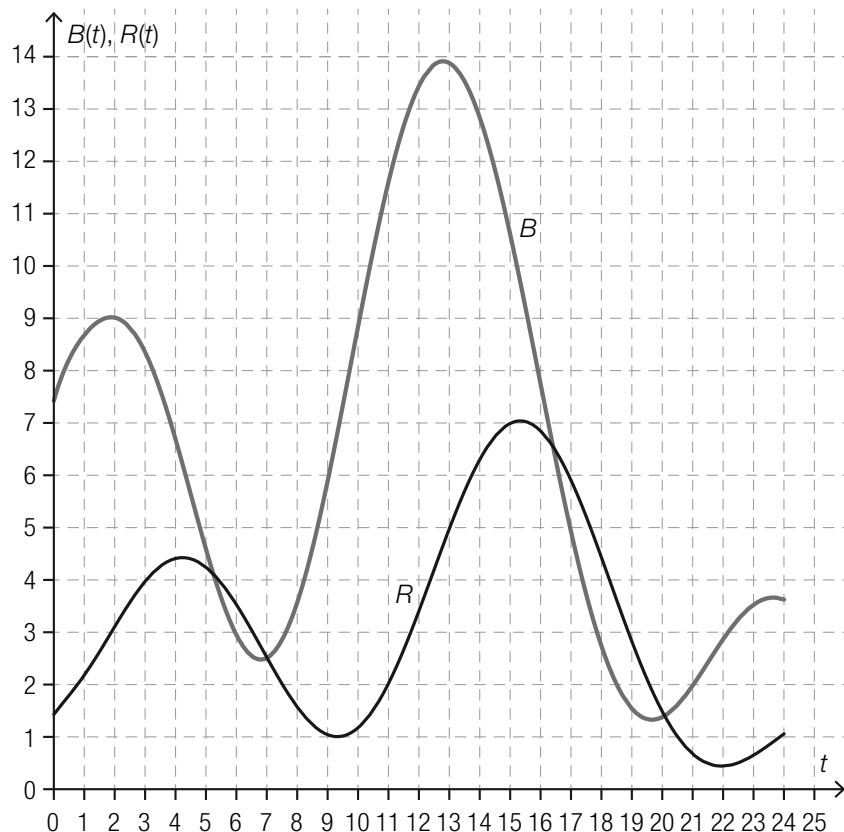

Task:

Write down all of the intervals in the observed time period for which both the predator and prey populations are decreasing.

Task 10

Linear Functions

The graphs of four different linear functions f where $f(x) = m \cdot x + c$ and $m, c \in \mathbb{R}$ are shown in the diagram below.

Task:

Match each of the four graphs to the corresponding statement about the parameters m and c (from A to F).

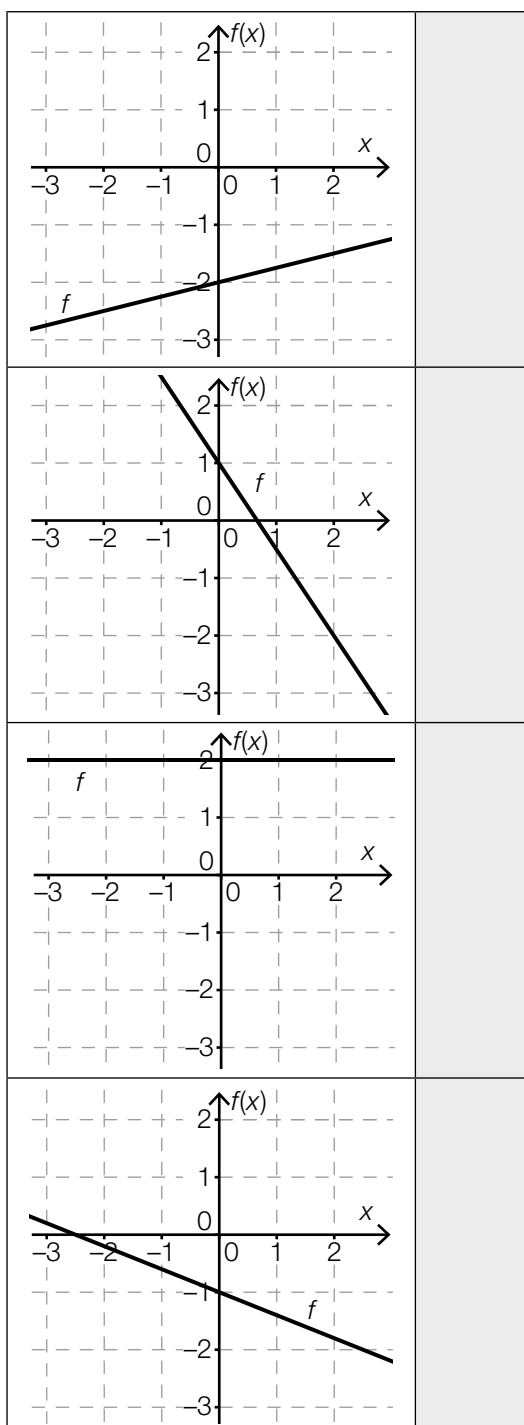

A	$m = 0, c < 0$
B	$m > 0, c > 0$
C	$m = 0, c > 0$
D	$m < 0, c < 0$
E	$m > 0, c < 0$
F	$m < 0, c > 0$

Task 11

Negative Values of a Function

Let f be a real function with equation $f(x) = x^2 - x - 6$. A value of the function $f(x)$ is negative if $f(x) < 0$.

Task:

Determine all $x \in \mathbb{R}$ for which the corresponding value of the function $f(x)$ is negative.

Task 12

Half-Life of Cobalt-60

The radioactive isotope cobalt-60 is used, among other purposes, for preserving food and in medicine.

The law of decay for cobalt-60 is $N(t) = N_0 \cdot e^{-0.13149 \cdot t}$ where t is measured in years. In this expression, N_0 gives the amount of the isotope at time $t = 0$ and $N(t)$ the amount at time $t \geq 0$.

Task:

Determine the half-life of cobalt-60.

Task 13

Performance Improvement

Three people, *A*, *B* and *C*, undertake a coordination test both before and after a special training programme. The numbers of points achieved in the test are shown in the table below.

	Person <i>A</i>	Person <i>B</i>	Person <i>C</i>
Number of points achieved before the special training programme	5	15	20
Number of points achieved after the special training programme	8	19	35

A good performance is shown by a high number of points. It is evident from the table that all three people achieve more points after the special training programme than they did previously.

Task:

List the two people from the group *A*, *B*, *C* that satisfy the conditions given below.

- For the first person, the absolute change in the number of points is greater than for the second person.
- For the second person, the relative change in the number of points is greater than for the first person.

First person: _____

Second person: _____

Task 14

Financial Debt

The financial debt of Austria increased in the time period from 2000 to 2010. In the year 2000, Austria's financial debt amounted to F_0 ; ten years later it amounted to F_1 (each in billions of euros).

Task:

Interpret the expression $\frac{F_1 - F_0}{10}$ in the context of the development of Austria's financial debt.

Task 15

Difference Equation

The table below contains the values of a sequence at time n ($n \in \mathbb{N}$).

n	x_n
0	10
1	21
2	43
3	87

The development of this sequence over time can be described by a difference equation of the form $x_{n+1} = a \cdot x_n + b$.

Task:

Write down the values of the (real) parameters a and b that describe the sequence shown in the table above.

$a =$ _____

$b =$ _____

Task 16

Depth of a Channel

As a preventative measure in the event of high water, a town has installed a channel (or water course).

The function f describes the depth of the water in the channel in the event of high water in terms of the time t at a particular point in the channel in the time interval $[0, 2]$.

The equation of the function f is $f(t) = t^3 + 6 \cdot t^2 + 12 \cdot t + 8$ where $t \in [0, 2]$.

In this function, $f(t)$ is measured in dm and t in days.

Task:

Write down an equation of the function g that gives the instantaneous rate of change of the depth of the water in the channel (in dm per day) in terms of time t .

$g(t) =$ _____

Task 17

Differentiating Graphically

The graph of a third degree polynomial function f is shown below.

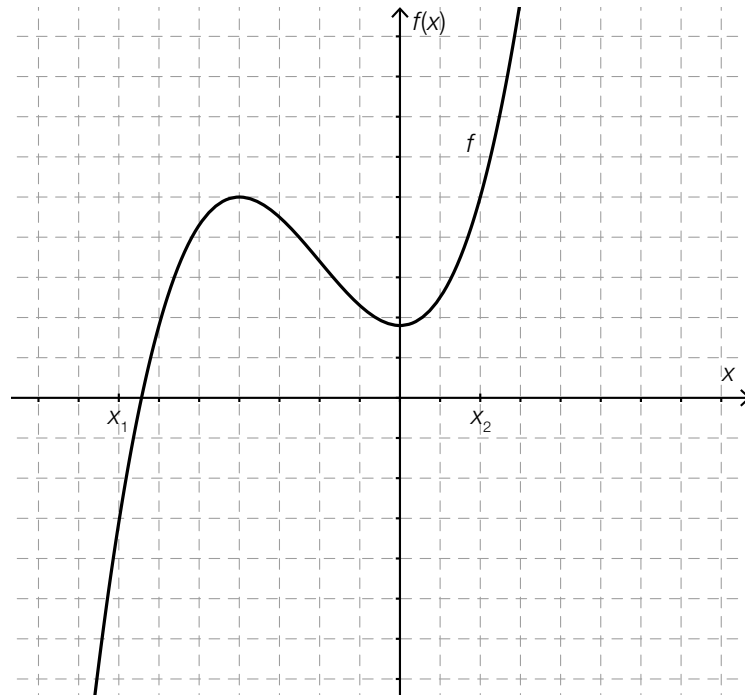

Task:

Sketch the graph of the first derivative f' in the interval $[x_1, x_2]$ on the diagram above and mark the zeros as necessary.

Task 18

Amount of Water in a Container

In the diagram shown below, the instantaneous rate of change R of the amount of water in a container (in m^3/h) is shown in terms of the time t .

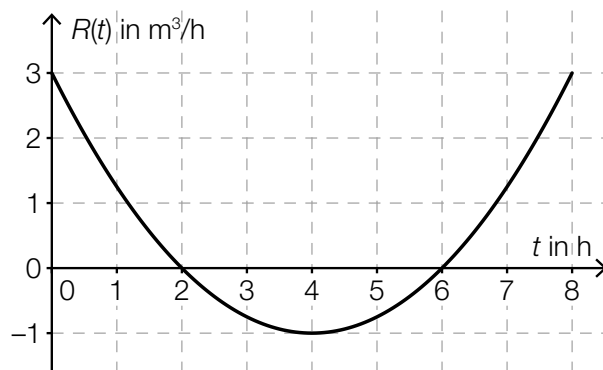

Task:

Put a cross next to each of the two correct statements about the amount of water in the container.

At time $t = 6$ there is less water in the container than at time $t = 2$.	<input type="checkbox"/>
In the time interval $(6, 8)$ the amount of water in the container increases.	<input type="checkbox"/>
At time $t = 2$ there is no water in the container.	<input type="checkbox"/>
In the time interval $(0, 2)$ the amount of water in the container decreases.	<input type="checkbox"/>
At time $t = 4$ there is the least water in the container.	<input type="checkbox"/>

Task 19

Migration Balance for Austria

In a given time period, the difference between the number of immigrants that come into a country and the number of emigrants that leave a country in this period is known as the *migration balance*.

In the diagram below, the annual migration balance for Austria is shown for the years from 1961 to 2012.

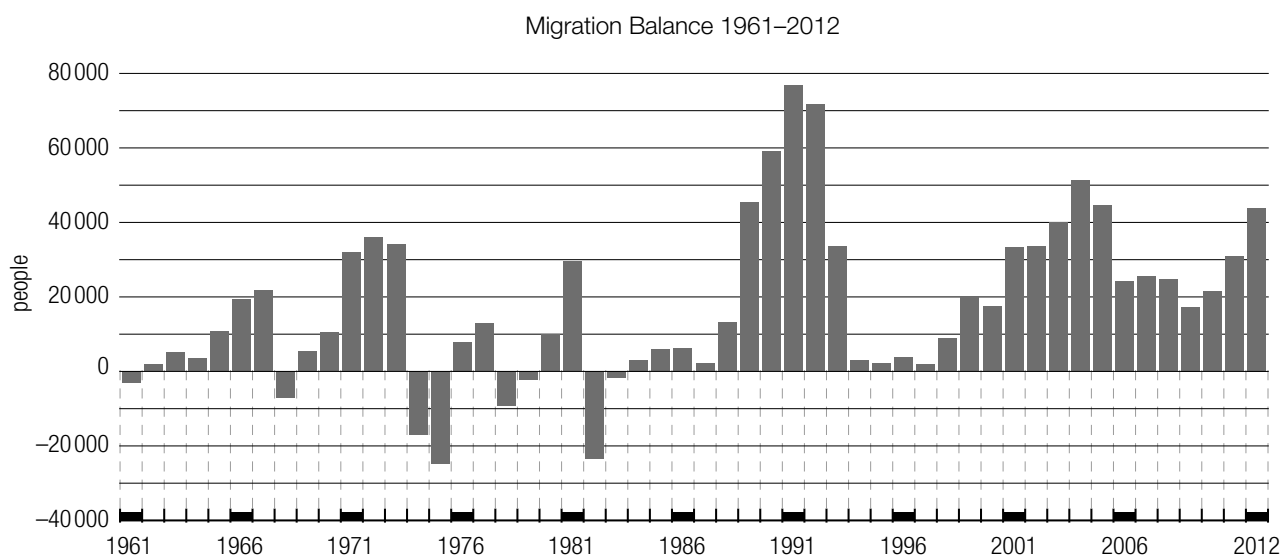

Source: STATISTIK AUSTRIA, *Errechnete Wanderungsbilanz 1961–1995; Wanderungsstatistik 1996–2012; 2007–2011: revidierte Daten. Wanderungsbilanz: Zuzüge aus dem Ausland minus Wegzüge in das Ausland (adapted).*

Task:

Put a cross next to each of the two statements that give a correct interpretation of the diagram.

From the value given for the year 2003, the diagram shows that around 40,000 more people immigrated than emigrated in that year.	<input type="checkbox"/>
The growth in the migration balance from the year 2003 to the year 2004 is around 50 %.	<input type="checkbox"/>
In the time period from 1961 to 2012, there are eight years for which the number of immigrants was smaller than the number of emigrants.	<input type="checkbox"/>
In the time period from 1961 to 2012, there are three years for which the number of immigrants was equal to the number of emigrants.	<input type="checkbox"/>
The migration balance for the year 1981 is approximately twice as large as it was for the year 1970.	<input type="checkbox"/>

Task 20

Alarm Systems

In the case of a break-in, a particular alarm system is triggered with a probability of 0.9. A family has two of these systems installed in their house in such a way that the alarms are triggered independently of one another.

Task:

Determine the probability that at least one of the alarms sounds if the house is broken into.

Task 21

Youth Group

A youth group has 21 members. For a game, teams should be formed.

Task:

Complete the following sentence by putting a cross next to one of the given possibilities for each gap so that the sentence becomes a correct statement.

The binomial coefficient $\binom{21}{3}$ gives _____ ① _____; its value is _____ ② _____.

①	
how many of the 21 members are in a team if three equally-sized teams are formed	<input type="checkbox"/>
how many different possibilities there are to form teams of three from the 21 members	<input type="checkbox"/>
in how many ways three different tasks can be allocated to three members of the youth group	<input type="checkbox"/>

②	
7	<input type="checkbox"/>
1,330	<input type="checkbox"/>
7,980	<input type="checkbox"/>

Task 22

Statements about a Random Variable

The random variable X can only take the values 10, 20 and 30. The table below shows the probability distribution of X , where a and b are positive real numbers.

k	10	20	30
$P(X = k)$	a	b	a

Task:

Put a cross next to each of the two correct statements.

The expectation value of X is 20.	<input type="checkbox"/>
The standard deviation of X is 20.	<input type="checkbox"/>
$a + b = 1$	<input type="checkbox"/>
$P(10 \leq X \leq 30) = 1$	<input type="checkbox"/>
$P(X \leq 10) = P(X \geq 10)$	<input type="checkbox"/>

Task 23

Graphical Interpretation

The density function f of the approximated normal distribution of a binomially distributed random variable X is shown in the diagram below.

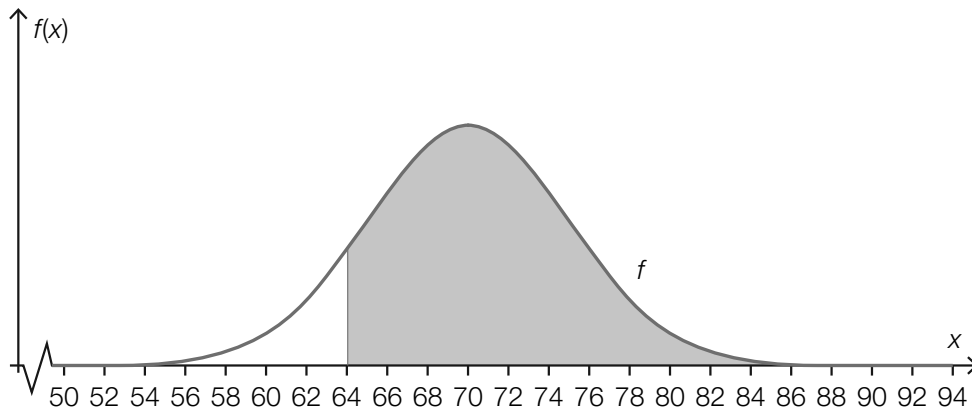

Task:

Interpret the meaning of the area of the section shaded in grey with respect to the calculation of a probability.

Task 24

Election Forecast

In order to predict the proportion of votes for a particular party *A*, a sample of randomly selected voters is surveyed.

The survey results in a 95 % confidence interval for the proportion of votes of [9.8 %, 12.2 %].

Task:

Which of the following statements are definitely true in this context?

Put a cross next to each of the two correct answers.

The probability that a randomly selected voter votes for party <i>A</i> definitely lies between 9.8 % and 12.2 %.	<input type="checkbox"/>
For the data collected, a 90 % confidence interval would have had a smaller range.	<input type="checkbox"/>
Under the condition that the proportion of voters for party <i>A</i> stays the same in the sample, then an increase in the sample size would result in a reduction in size of the 95 % confidence interval.	<input type="checkbox"/>
95 out of 100 people say that they will vote for party <i>A</i> with a probability of 11 %.	<input type="checkbox"/>
The probability that party <i>A</i> receives more than 12.2 % of the votes is 5 %.	<input type="checkbox"/>

Task 1

Sets of Numbers

Below you will see statements relating to numbers from the sets \mathbb{N} , \mathbb{Z} , \mathbb{Q} , \mathbb{R} and \mathbb{C} .

Task:

Put a cross next to each of the true statements.

Every real number is also a rational number.	<input type="checkbox"/>
Every natural number is also a rational number.	<input type="checkbox"/>
Every integer is also a real number.	<input type="checkbox"/>
Every rational number is also a real number.	<input type="checkbox"/>
Every complex number is also a real number.	<input type="checkbox"/>

Task 2

Solutions to a Quadratic Equation

Let $x^2 + p \cdot x - 3 = 0$ where $p \in \mathbb{R}$ be a quadratic equation.

Task:

Complete the sentence below by putting a cross next to one of the given possibilities for each gap so that the sentence becomes a correct statement.

This equation has _____^①_____, when _____^②_____ holds.

①	
infinitely many real solutions	<input type="checkbox"/>
exactly one real solution	<input type="checkbox"/>
no real solutions	<input type="checkbox"/>

②	
$\frac{p^2}{4} + 3 > 0$	<input type="checkbox"/>
$\frac{p^2}{4} + 3 < 0$	<input type="checkbox"/>
$\frac{p^2}{4} + 3 > 1$	<input type="checkbox"/>

Task 3

Project Week

A total of 25 students are going to participate in a project week. The number of girls is represented by x and the number of boys by y . The girls will sleep in rooms with 3 beds and the boys will sleep in rooms with 4 beds. There are 7 bedrooms available in total. The beds in all 7 rooms will be used; there will be no empty beds left over.

Task:

Using a system of equations comprised of two of the equations shown below, the number of girls and the number of boys can be calculated.

Put a cross next to each of the two correct equations.

$x + y = 7$	<input type="checkbox"/>
$x + y = 25$	<input type="checkbox"/>
$3 \cdot x + 4 \cdot y = 7$	<input type="checkbox"/>
$\frac{x}{3} + \frac{y}{4} = 7$	<input type="checkbox"/>
$\frac{x}{3} + \frac{y}{4} = 25$	<input type="checkbox"/>

Task 4

Sausage Stand

The owner of a sausage stand keeps records of the amount of sausages sold in a day. The records for one particular day are shown in the table below.

Type of sausage	Amount of portions sold	Price at which a portion is sold (in euros)	Cost to the owner of each portion (in euros)
Frankfurter	24	2.70	0.90
Debreziner	14	3.00	1.20
Burenwurst	11	2.80	1.00
Käsekrainer	19	3.20	1.40
Bratwurst	18	3.20	1.20

The numbers of each column of the table can be written as vectors. The vector A gives the number of portions sold, the vector B gives the prices at which each portion is sold (in euros), and the vector C gives the cost to the owner of each portion (in euros).

Task:

Write down an expression using the vectors A , B , and C that gives the sausage stand owner's total profit on this day regarding the sale of the sausages.

Total profit = _____

Task 5

Two-Dimensional Vectors

The diagram below shows two vectors, \vec{a} and \vec{b} .

Task:

In the diagram, draw a vector \vec{c} such that the sum of the three vectors gives the zero vector, i. e. so that $\vec{a} + \vec{b} + \vec{c} = \begin{pmatrix} 0 \\ 0 \end{pmatrix}$.

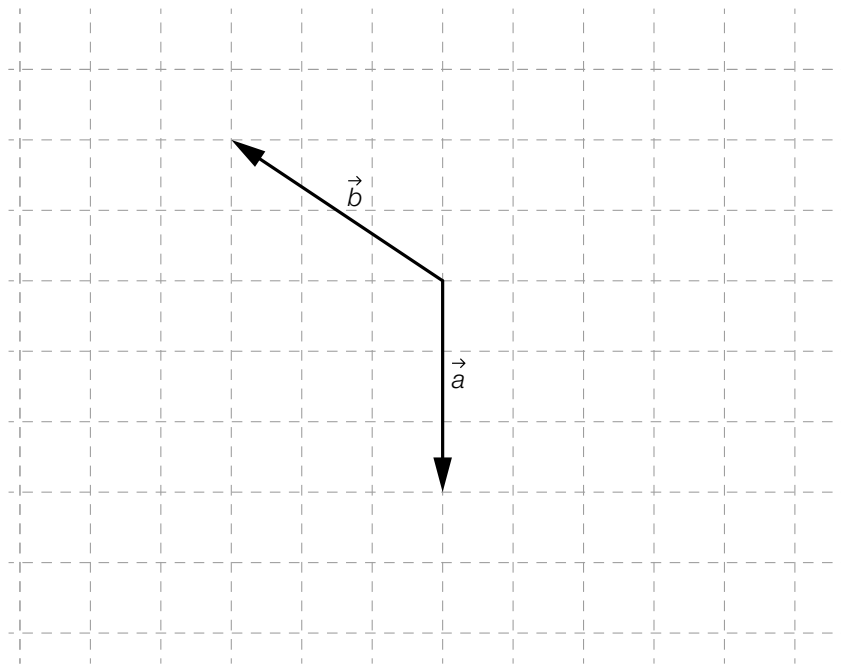

Task 6

Rate of Descent

A light aircraft is approaching to land at an angle of α (in degrees) to the horizontal. The aircraft has an air speed of v (in m/s).

Task:

Write down a formula for the loss of altitude, x (in m), that this aircraft experiences in one second at this angle and air speed.

Task 7

Types of Functions

Below you will see four equations of functions (where $a, b \in \mathbb{R}^+$) and the graphs of six real functions.

Task:

Match each of the four equations of functions with their corresponding graph (from A to F).

$f(x) = a \cdot \sin(b \cdot x)$	
$f(x) = a \cdot b^x$	
$f(x) = a \cdot \sqrt{x} + b$	
$f(x) = a \cdot x + b$	

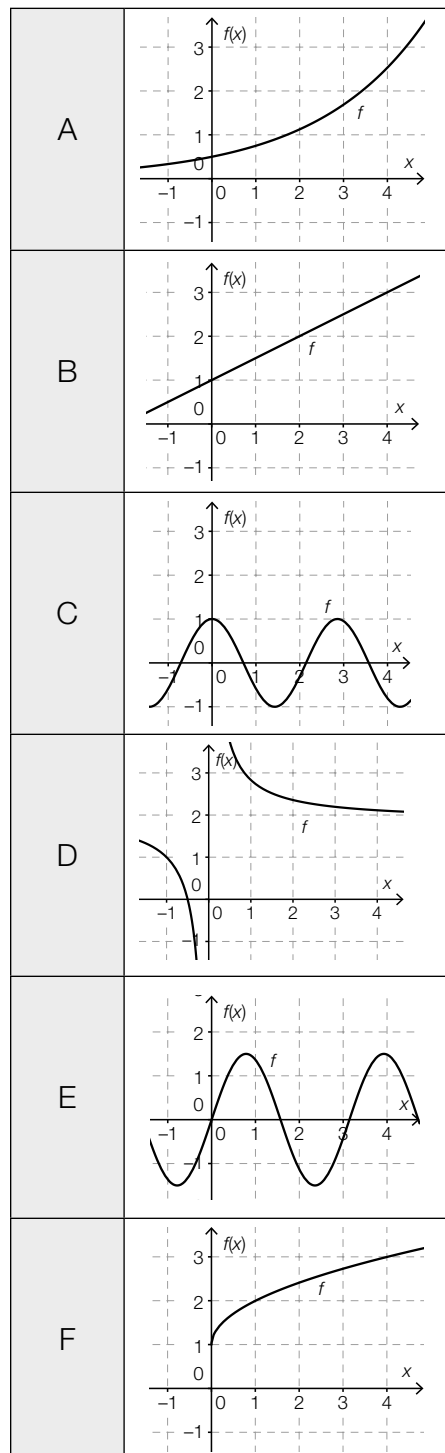

Task 8

Value of an Asset

The value of a particular asset t years after its acquisition is represented by $W(t)$ and can be calculated using the equation $W(t) = -k \cdot t + d$ ($k, d \in \mathbb{R}^+$) ($W(t)$ is given in euros).

Task:

Write down the meaning of the parameters k and d with respect to the value of the asset.

Task 9

Parameters of a Real Function

The diagram below shows the graphs of two real functions f and g with equations $f(x) = a \cdot x^3 + b$ and $g(x) = c \cdot x^3 + d$ where $a, b, c, d \in \mathbb{R}$.

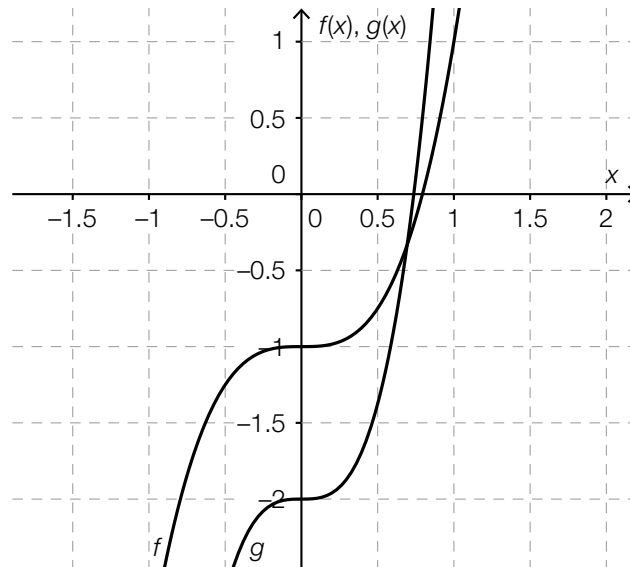

Task:

Which of the statements below are true for the parameters $a, b, c,$ and d ?
Put a cross next to each of the two correct statements.

$a > c$	<input type="checkbox"/>
$b > d$	<input type="checkbox"/>
$a > 0$	<input type="checkbox"/>
$b > 0$	<input type="checkbox"/>
$c < 1$	<input type="checkbox"/>

Task 10

Exponential Function

For an exponential function f , the following values are known:

$$f(0) = 12 \text{ and } f(4) = 192$$

Task:

Write down the equation of the exponential function f .

$$f(x) = \underline{\hspace{15cm}}$$

Task 11

Thickness of a Lead Layer

The intensity of electromagnetic radiation decreases exponentially when it penetrates a body.

The half-value thickness of a material is the thickness at which the intensity of radiation is reduced by a half when the material is penetrated. The half-value thickness of lead for the radiation observed is 0.4 cm.

Task:

Determine the necessary thickness, d , of a lead layer so that the intensity is reduced to 12.5 % of the original intensity.

$d =$ _____ cm

Task 12

Periodicity

Let f be a real function with equation $f(x) = 3 \cdot \sin(b \cdot x)$ where $b \in \mathbb{R}$.

Task:

One of the values below gives the (smallest) period length of the function f . Put a cross next to the correct value.

$\frac{b}{2}$	<input type="checkbox"/>
b	<input type="checkbox"/>
$\frac{b}{3}$	<input type="checkbox"/>
$\frac{\pi}{b}$	<input type="checkbox"/>
$\frac{2\pi}{b}$	<input type="checkbox"/>
$\frac{\pi}{3}$	<input type="checkbox"/>

Task 13

Salary of an Employee

The gross salary of a particular employee was € 2,160 per month in the year 2008.

The employee's monthly gross salary increased over the following six years by an average of € 225 per year.

Task:

Determine the percentage change of the employee's monthly gross salary across the whole period from 2008 to 2014.

Task 14

Swimming Pool

Water is let into a swimming pool from the time $t = 0$.

The function h represents the height of the surface of the water at time t . The height, $h(t)$, is measured in dm and the time, t , is measured in hours.

Task:

Interpret the result of the following calculation in the given context.

$$\frac{h(5) - h(2)}{5 - 2} = 4$$

Task 15

Sine Function and Cosine Function

Let f and g be functions where $f(x) = \sin(a \cdot x)$ and $g(x) = a \cdot \cos(a \cdot x)$ with $a \in \mathbb{R}$.

Task:

Which relationship holds between the functions f and g and their first derivatives? Put a cross next to the equation that holds for all $a \in \mathbb{R}$.

$a \cdot f'(x) = g(x)$	<input type="checkbox"/>
$g'(x) = f(x)$	<input type="checkbox"/>
$a \cdot g(x) = f'(x)$	<input type="checkbox"/>
$f(x) = a \cdot g'(x)$	<input type="checkbox"/>
$f'(x) = g(x)$	<input type="checkbox"/>
$g'(x) = a \cdot f(x)$	<input type="checkbox"/>

Task 16

Differentiating an Exponential Function

Let f be a function where $f(x) = e^{\lambda \cdot x}$ with $\lambda \in \mathbb{R}$.

The diagram below shows the graphs of the function f and its first derivative f' .

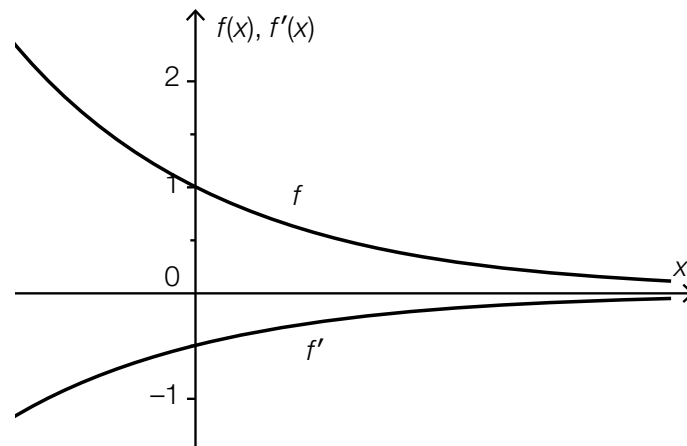

Task:

Determine the value of the parameter λ .

$\lambda =$ _____

Task 17

Distance-Time Function

The linear motion of a car is represented by the distance-time function s . Within a given observation period, the function s is strictly monotonically increasing and concave down.

Task:

Put a cross next to each of the two true statements for this observation period.

The speed of the car is always increasing.	<input type="checkbox"/>
The values of the function s' are negative.	<input type="checkbox"/>
The values of the function s'' are negative.	<input type="checkbox"/>
The value of the difference quotient of s in the given time period is negative.	<input type="checkbox"/>
The value of the differential quotient of s is always decreasing.	<input type="checkbox"/>

Task 18

Area Calculation

The graphs of the polynomial functions f and g are shown in the diagram below. The graphs cross when $x = -3$, $x = 0$ and $x = 3$ and bound the two areas shaded in grey.

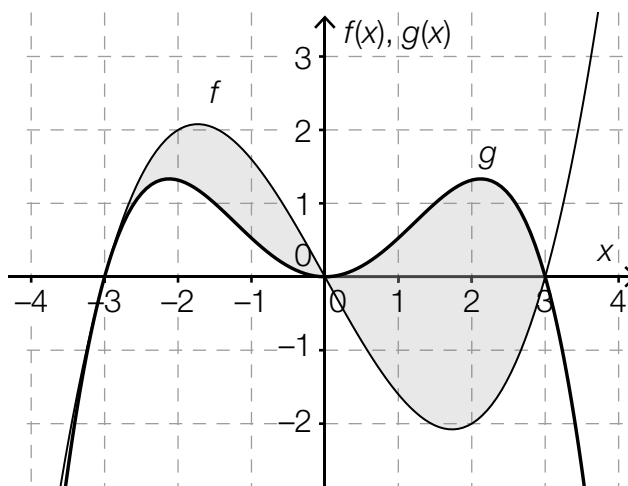

Task:

Which of the equations shown below give the area, A , of the (whole) area shaded in grey? Put a cross next to each of the two correct equations.

$A = \left \int_{-3}^3 (f(x) - g(x)) dx \right $	<input type="checkbox"/>
$A = 2 \cdot \int_0^3 (g(x) - f(x)) dx$	<input type="checkbox"/>
$A = \int_{-3}^0 (f(x) - g(x)) dx + \int_0^3 (g(x) - f(x)) dx$	<input type="checkbox"/>
$A = \left \int_{-3}^0 (f(x) - g(x)) dx \right + \int_0^3 (f(x) - g(x)) dx$	<input type="checkbox"/>
$A = \int_{-3}^0 (f(x) - g(x)) dx + \left \int_0^3 (f(x) - g(x)) dx \right $	<input type="checkbox"/>

Task 19

Stem and Leaf Diagram

The stem and leaf diagrams shown below give the number of cinema goers per showing of the films *A* and *B* over the course of a week. In the diagrams, the unit of the stem is 10 and the unit of the leaf is 1.

Film A	
2	0, 3, 8
3	6, 7
4	1, 1, 5, 6
5	2, 6, 8, 9
6	1, 8

Film B	
2	1
3	1, 4, 5
4	4, 5, 8
5	0, 5, 7, 7
6	1, 2
7	0

Task:

Put a cross next to each of the statements that are definitely true based on the information shown in the stem and leaf diagrams.

In this week there were more showings of film <i>A</i> than of film <i>B</i> .	<input type="checkbox"/>
The median number of viewers for film <i>A</i> is higher than for film <i>B</i> .	<input type="checkbox"/>
The range of the number of viewers is smaller for film <i>A</i> than for film <i>B</i> .	<input type="checkbox"/>
The total number of viewers for film <i>A</i> was greater than for film <i>B</i> in this week.	<input type="checkbox"/>
In one of the showings for film <i>B</i> , there were more viewers than in any of the individual showings of film <i>A</i> .	<input type="checkbox"/>

Task 20

Estimate of a Probability

In a factory, a product is produced by a machine with 100 items being placed in one batch.

Following a recalibration of the machine, three batches of products are produced. These batches are checked to determine the number of rejects they contain. The results of this check are displayed in the table below.

in the first batch	6 rejects
in the second batch	3 rejects
in the third batch	4 rejects

The factory's management requires an estimate of the probability, p , that a new product produced by the machine is rejected based on the data given above.

Task:

Determine an estimate for the probability p that is as reliable as possible that a new product produced by the machine is rejected.

$p =$ _____

Task 21

Ludo

In order to place a playing piece on the board at the beginning of a game of *Ludo*, a player has to roll a six using a fair dice (a dice is considered to be “fair” if the probability of the dice showing any of its six faces after being thrown is equal for all six faces).

According to the rules of the game, the number of attempts to roll a six is limited to three attempts before the next player takes their turn.

Task:

Determine the probability that a playing piece can be placed on the board after a maximum of three attempts to roll a six.

Task 22

Determining a Probability

The diagram below shows the probability distribution of a random variable X .

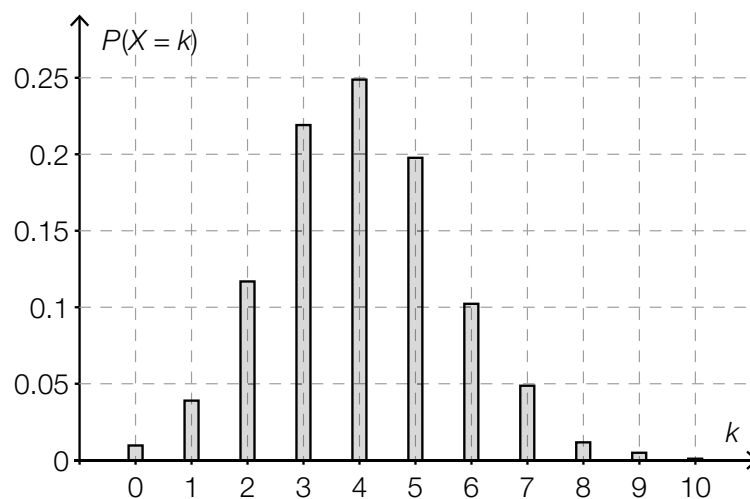

Task:

Using the diagram, determine an approximate value for the probability $P(4 \leq X < 7)$.

$P(4 \leq X < 7) \approx$ _____

Task 23

Tyres

The probability that a new tyre produced by a particular brand becomes damaged in the first 10,000 km of driving due to a fault in the material is p %.

A random sample of 80 new tyres from this brand is tested.

Task:

Write down an expression that could be used to calculate the probability that at least one of these tyres becomes damaged in the first 10,000 km of driving due to a fault in the material.

Task 24

Confidence Interval

For an election forecast, a random sample is selected from all those eligible to vote. Out of 400 people, 80 say they intend to vote for party Y.

Task:

Determine a symmetrical 95 % confidence interval for the proportion of voters for party Y out of the whole population of voters.

Task 1

Number of People on a Bus

The variable F represents the number of female passengers on a bus. The variable M represents the number of male passengers on the same bus. Including the (male) driver, there are twice as many men as women on the bus. (The driver is not included in the passenger count.)

Task:

Put a cross next to the equation that correctly describes the relationship between the number of women and the number of men on the bus.

$2 \cdot (M + 1) = F$	<input type="checkbox"/>
$M + 1 = 2 \cdot F$	<input type="checkbox"/>
$F = 2 \cdot M + 1$	<input type="checkbox"/>
$F + 1 = 2 \cdot M$	<input type="checkbox"/>
$M - 1 = 2 \cdot F$	<input type="checkbox"/>
$2 \cdot F = M$	<input type="checkbox"/>

Task 2

Train Journeys

A goods train departs from Salzburg in the direction of Linz at 8.00 a. m. The train station at Linz is 124 km away from the train station at Salzburg. Half an hour after the goods train has departed, an express train leaves Linz and travels towards Salzburg. The goods train travels at an average speed of 100 km/h, and the average speed of the express train is 150 km/h.

Task:

The time it takes for the goods train to encounter the train from Linz is represented by t and is measured in hours.

Write down an equation that can be used to calculate the time t and calculate this time.

Task 3

Solution to a Quadratic Equation

An equation that can be brought into the form $a \cdot x^2 + b \cdot x + c = 0$ where $a, b, c \in \mathbb{R}$ and $a \neq 0$ is known as a quadratic equation in the variable x with coefficients a, b, c .

Task:

Complete the following sentence by putting a cross next to one of the given possibilities for each gap so that the sentence is a correct statement.

A quadratic equation of the form $a \cdot x^2 + b \cdot x + c = 0$ where _____^①_____ definitely has _____^②_____.

①	
$a > 0$ and $c > 0$	<input type="checkbox"/>
$a > 0$ and $c < 0$	<input type="checkbox"/>
$a < 0$ and $c < 0$	<input type="checkbox"/>

②	
two distinct real solutions	<input type="checkbox"/>
exactly one real solution	<input type="checkbox"/>
no real solutions	<input type="checkbox"/>

Task 4

Orthogonal Vectors

Below, you will see some vectors.

$$\vec{a} = \begin{pmatrix} 2 \\ 3 \end{pmatrix}$$

$$\vec{b} = \begin{pmatrix} x \\ 0 \end{pmatrix}, x \in \mathbb{R}$$

$$\vec{c} = \begin{pmatrix} 1 \\ -2 \end{pmatrix}$$

$$\vec{d} = \vec{a} - \vec{b}$$

Task:

Determine the value of x such that the vectors \vec{c} and \vec{d} are perpendicular to each other.

Task 5

Gradient of a Gutter

A gutter has a particular length l (in metres). So that water can run off well, the gutter has to be positioned at an angle of at least α to the horizontal. Therefore, there is a difference in height of at least h metres between the two end points of the gutter.

Task:

Write down a formula that can be used to calculate h in terms of l and α .

$h =$ _____

Task 6

Angles in the Unit Circle

The diagram below shows an angle α in the unit circle.

Task:

In the diagram, sketch the angle β in the interval $[0^\circ, 360^\circ]$ where $\beta \neq \alpha$ for which $\cos(\beta) = \cos(\alpha)$ holds.

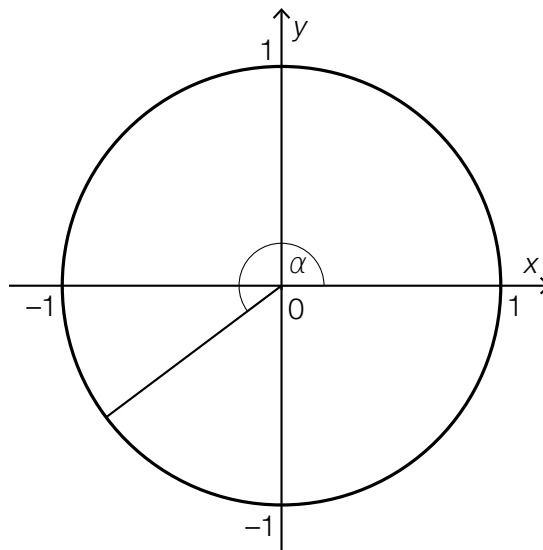

Task 7

Stefan-Boltzmann Law

The luminosity L of a star is given by the following formula:

$$L = 4 \cdot \pi \cdot R^2 \cdot T^4 \cdot \sigma$$

In the formula, R is the radius of the star and T is the surface temperature of the star; σ is a constant (the so-called Stefan-Boltzmann constant).

Task:

Complete the following sentence by putting a cross next to one of the given possibilities for each gap so that the sentence is a correct statement.

For different stars with the same, known radius R , the luminosity L is a function of ①, and the function becomes ②.

①	
the radius of the star, R	<input type="checkbox"/>
the surface temperature, T	<input type="checkbox"/>
the constant, σ	<input type="checkbox"/>

②	
a linear function	<input type="checkbox"/>
a power function	<input type="checkbox"/>
an exponential function	<input type="checkbox"/>

Task 8

Points of Intersection

The diagram below shows the graph of the function f where $f(x) = x^2 - 4 \cdot x - 2$ and the graph of the function g where $g(x) = x - 6$ as well as their points of intersection A and B .

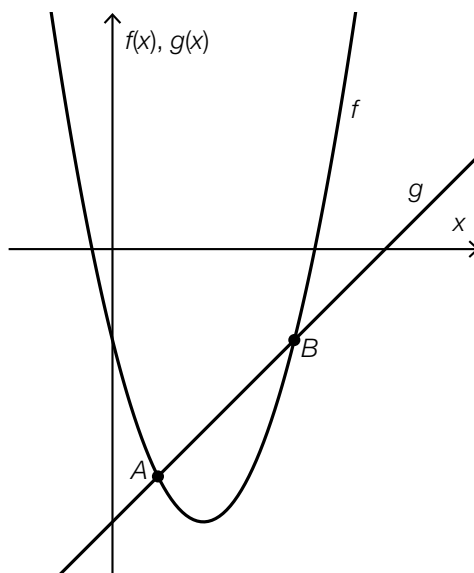

Task:

Determine the coefficients a and b of the quadratic equation $x^2 + a \cdot x + b = 0$ such that the two solutions to this equation are the x -coordinates of the points of intersection A and B .

Task 9

Gradient of a Linear Function

The graph of a linear function f goes through the points $A = (a, b)$ and $B = (5 \cdot a, -3 \cdot b)$ where $a, b \in \mathbb{R} \setminus \{0\}$.

Task:

Determine the gradient m of the linear function f .

$m =$ _____

Task 10

Pattern of Change

The pattern of how a quantity N changes over time t is described by the equation $N(t) = 1.2 \cdot 0.98^t$.

Task:

Which of the patterns of change described below can be represented by the equation given above? Put a cross next to the correct pattern of change.

Per unit of time, 0.02 % of the amount of a radioactive substance left on a particular day decays.	<input type="checkbox"/>
Per unit of time, 0.02 m ³ of water flows into a reservoir.	<input type="checkbox"/>
Per unit of time, 1.2 mg of the active ingredient in a medication is broken down.	<input type="checkbox"/>
The number of inhabitants in a country increases by 1.2 % per unit of time.	<input type="checkbox"/>
The value of a property increases by 2 % per unit of time.	<input type="checkbox"/>
The temperature of a body reduces by 2 % per unit of time.	<input type="checkbox"/>

Task 11

Half-Life

The diagrams below show the graphs of exponential functions that each represents the amount remaining of a radioactive substance in terms of time.

The amount is given by $M(t)$ (in mg) at time t (in days).

Task:

Match each of the four graphs with the corresponding half-life (from A to F).

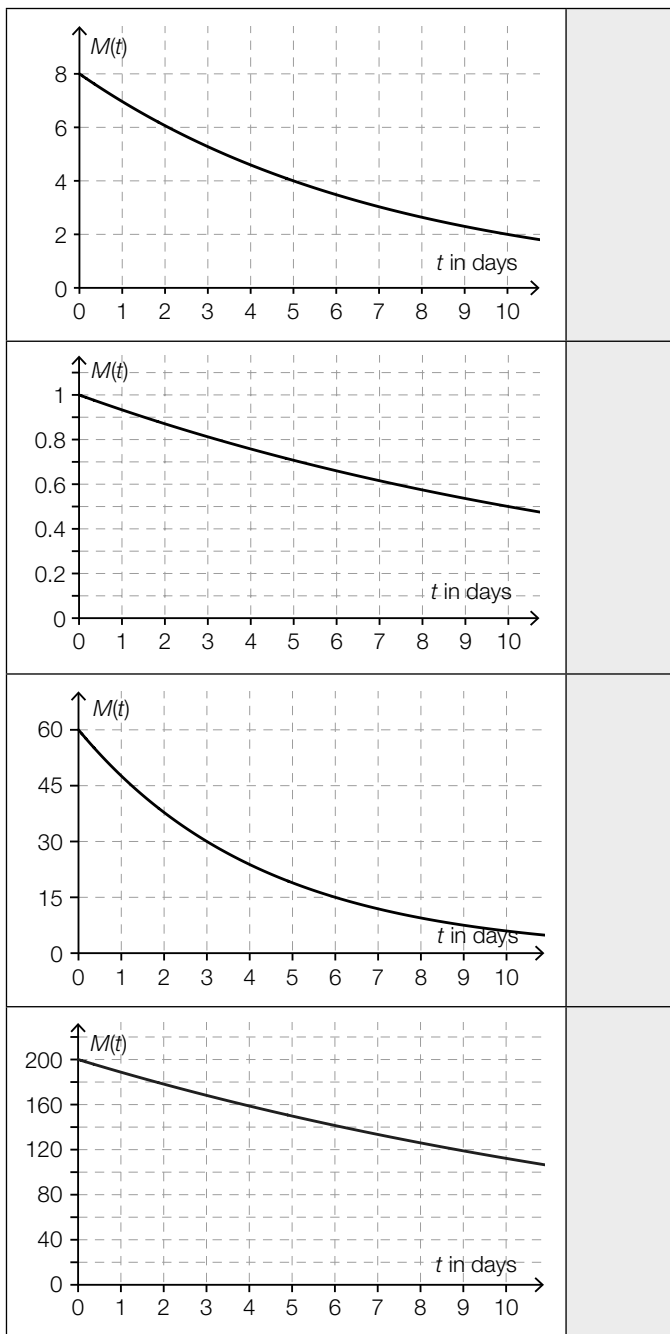

A	1 day
B	2 days
C	3 days
D	5 days
E	10 days
F	more than 10 days

Task 12

Parameters of a Sine Function

The graph of a function f where $f(x) = a \cdot \sin(b \cdot x)$ and $a, b \in \mathbb{R}^+$ is shown below.

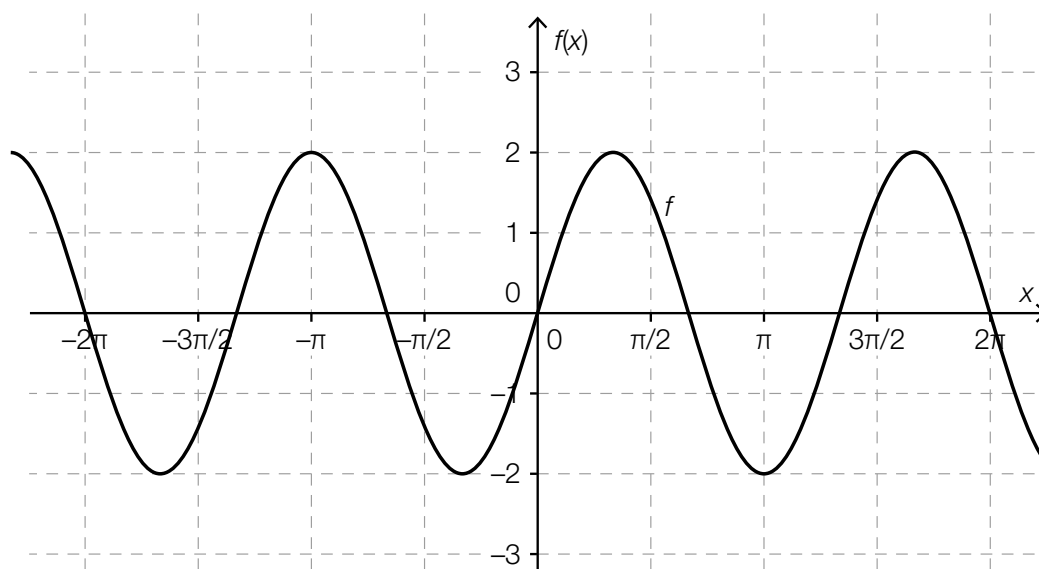

Task:

For the graph shown above, write down appropriate values for the parameters a and b .

$a =$ _____

$b =$ _____

Task 13

Radioactive Decay

The value $m(t)$ represents the amount of a radioactive substance that is left after t days.

Task:

One of the expressions shown below describes the relative change in the amount of the radioactive substance over the first three days.

Put a cross next to the correct expression.

$m(3) - m(0)$	<input type="checkbox"/>
$\frac{m(3) - m(0)}{3}$	<input type="checkbox"/>
$\frac{m(0)}{m(3)}$	<input type="checkbox"/>
$\frac{m(3) - m(0)}{m(0)}$	<input type="checkbox"/>
$\frac{m(3) - m(0)}{m(0) - m(3)}$	<input type="checkbox"/>
$m'(3)$	<input type="checkbox"/>

Task 14

Differentiation

Below you will see six equations of functions, each with a parameter k , where $k \in \mathbb{Z}$ and $k \neq 0$.

Task:

For which of the equations of functions shown below does the relationship $f'(x) = k \cdot f(x)$ hold for all $x \in \mathbb{R}$?

Put a cross next to the correct equation of a function.

$f(x) = k$	<input type="checkbox"/>
$f(x) = \frac{k}{x}$	<input type="checkbox"/>
$f(x) = k \cdot x$	<input type="checkbox"/>
$f(x) = x^k$	<input type="checkbox"/>
$f(x) = e^{k \cdot x}$	<input type="checkbox"/>
$f(x) = \sin(k \cdot x)$	<input type="checkbox"/>

Task 15

Area

The diagram below shows the graph of a third degree polynomial function f and the graph of its antiderivative F .

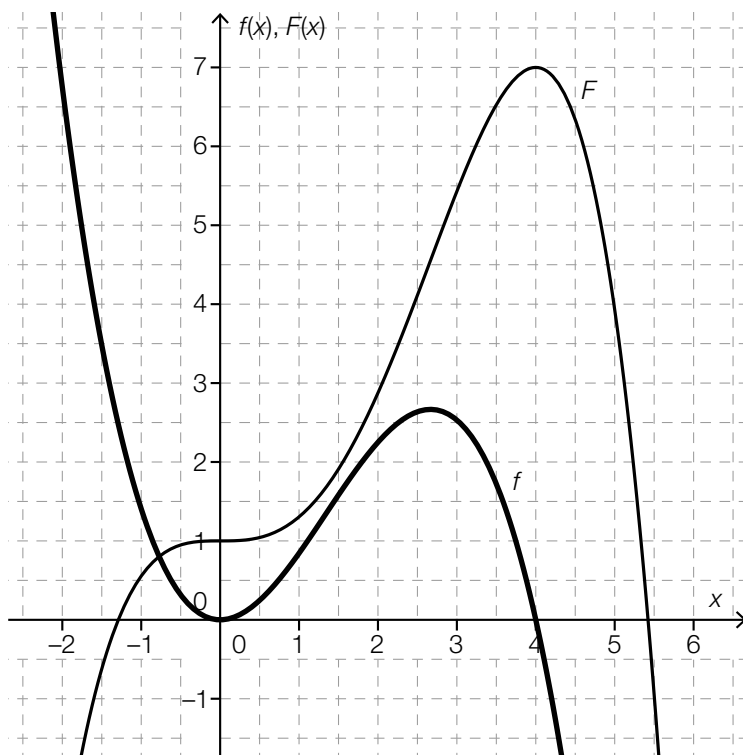

Task:

The graph of f and the positive x -axis enclose a finite area in the interval $[0, 4]$. Determine the area of this finite area.

Task 16

Point of Inflexion

A third degree polynomial function f can be differentiated to give f' where $f'(x) = 12 \cdot x^2 - 4 \cdot x - 8$.

Task:

Write down whether the function f has a point of inflexion at $x = 6$ and justify your answer.

Task 17

Definite Integral

The graph of a function f crosses the x -axis in a given region at the points a , b , c , d and e .

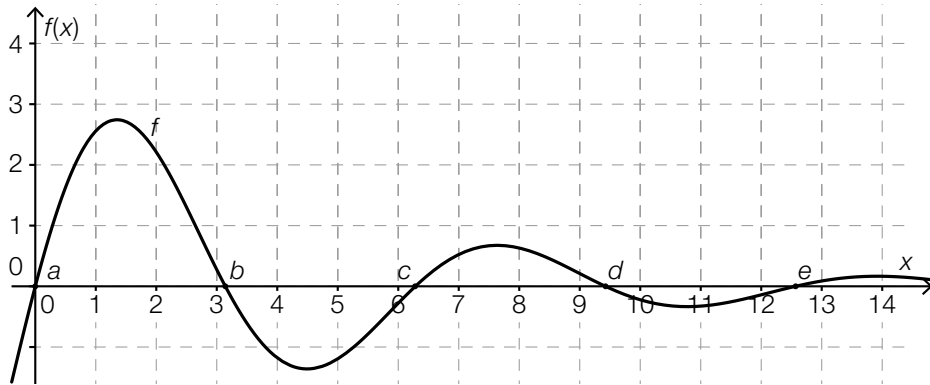

Task:

Which of the following definite integrals have a value that is greater than 0? Put a cross next to each of the two correct definite integrals.

$\int_a^c f(x) dx$	<input type="checkbox"/>
$\int_b^c f(x) dx$	<input type="checkbox"/>
$\int_b^d f(x) dx$	<input type="checkbox"/>
$\int_a^b f(x) dx$	<input type="checkbox"/>
$\int_d^e f(x) dx$	<input type="checkbox"/>

Task 18

Emissions

On a winter's day the emissions of a fireplace are measured.

The function $A: \mathbb{R}^+ \rightarrow \mathbb{R}^+$ represents the instantaneous amount of emissions $A(t)$ as a function of the time t in which $A(t)$ is measured in grams per hour and t in hours ($t = 0$ corresponds to midnight).

Task:

Interpret the expression $\int_7^{15} A(t) dt$ in the given context.

Task 19

Statistical Representations

The maximum temperature on each day during a very hot summer is measured by a meteorological station for the time period of one month. The readings in degrees Celsius can be read from the following stem and leaf diagram.

1	9
2	2 2 3 3 3
2	5 6 6 6 6 7 7 7 7 7 7 7
3	1 1 1 2 3 3 3 4 4 4
3	8
4	0 0

Task:

Draw a boxplot that represents the maximum daily temperatures listed above.

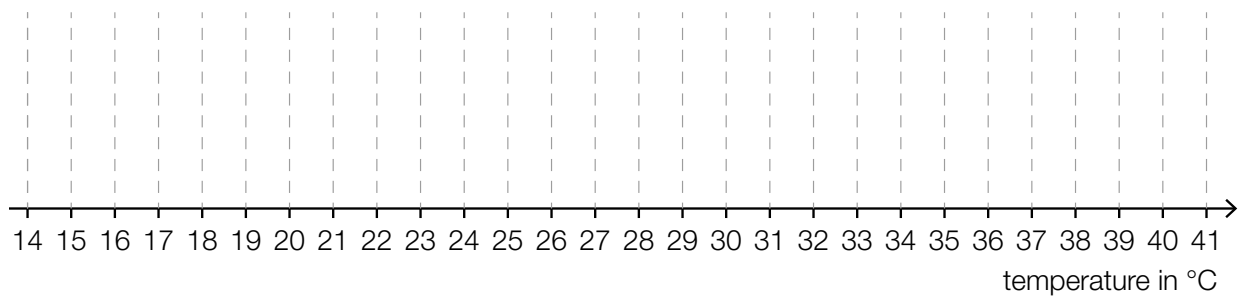

Task 20

Mean

There are 25 pupils in a class of which one pupil is an extraordinary pupil.

In a test, the mean score of all 25 pupils is 12.6 points. The mean score among the non-extraordinary pupils is 12.5 points.

Task:

Determine how many points the extraordinary pupil scored on this test.

Task 21

Examination

In order to receive funding for a period abroad, students have to complete an examination in either Spanish or English.

The tree diagram shown below shows the proportions of students who have taken the examination in each language. The tree diagram also shows the proportions of students who pass and fail the examination.

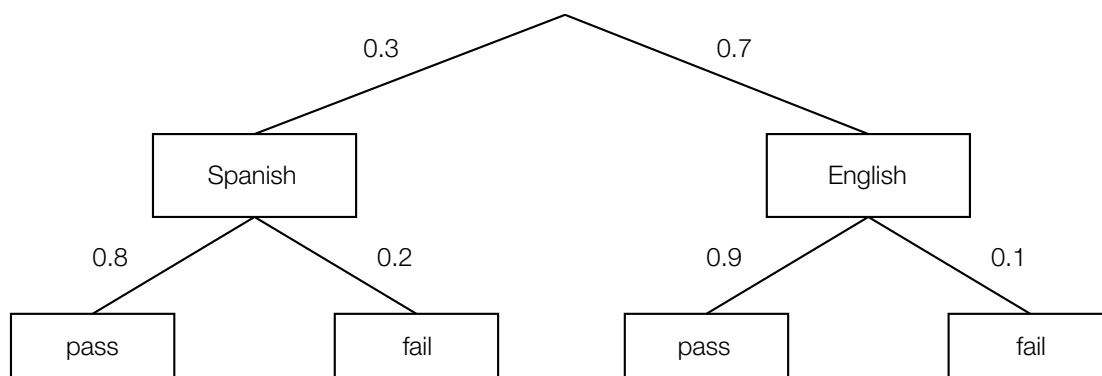

Task:

The examination paper of one particular student is selected at random.

Interpret the expression $0.7 \cdot 0.9 + (1 - 0.7) \cdot 0.8$ in the given context.

Task 22

Probability

The random variable X can take the values $\{0, 1, \dots, 9, 10\}$.

The two probabilities $P(X = 0) = 0.35$ and $P(X = 1) = 0.38$ are known.

Task:

Determine the probability $P(X \geq 2)$.

$P(X \geq 2) =$ _____

Task 23

Rose Bushes

A particular percentage of bushes of a type of rose bloom with yellow flowers.

A number of rose bushes of this type are planted in a bed. The random variable X is binomially distributed and gives the number of yellow-flowering rose bushes. The expectation value for the number X of yellow-flowering rose bushes is 32 and the standard deviation has the value 4.

The following comparison is made:

“The probability that there are at least 28 and at most 36 yellow-flowering rose bushes in this bed is greater than the probability that there are more than 32 yellow-flowering rose bushes.”

Task:

Write down whether this comparison is true and justify your answer.

Task 24

Certainty of a Confidence Interval

The filling system of a company has to be checked at regular intervals and may need to be reconfigured.

After a filling system has been configured, 30 out of 1 000 packs that were checked had not been filled correctly. For an unknown relative proportion p of packs that are not filled correctly, the company has determined the symmetrical confidence interval of $[0.02, 0.04]$.

Task:

Using a normal approximation of the binomial distribution, determine the certainty of this confidence interval.

Task 1

Sets of Numbers

The set $M = \{x \in \mathbb{Q} \mid 2 < x < 5\}$ is a subset of the rational numbers.

Task:

Put a cross next to each of the two correct statements.

4.99 is the largest number that is an element of set M .	<input type="checkbox"/>
There are infinitely many numbers in the set M that are smaller than 2.1.	<input type="checkbox"/>
Every real number that is greater than 2 and smaller than 5 is contained within the set M .	<input type="checkbox"/>
All elements of the set M can be written in the form $\frac{a}{b}$, where a and b are integers and $b \neq 0$.	<input type="checkbox"/>
The set M does not contain any numbers from the set of complex numbers.	<input type="checkbox"/>

Task 2

Equivalency

When rearranging an equation, not every rearrangement gives rise to an equivalent equation.

Task:

With specific reference to the example given below, explain why the rearrangement shown does not give rise to an equivalent equation. The equation is defined on the set of all real numbers.

$$\begin{array}{l} x^2 - 5x = 0 \quad | \div x \\ x - 5 = 0 \end{array}$$

Task 3

Fuel Costs

The average car requires y litres of fuel for each 100 km driven. The cost of the fuel is a euros per litre.

Task:

Write down an expression that gives the average fuel cost, K (in euros), for a journey of x km.

$K =$ _____

Task 4

Quadratic Equation

Let $x^2 + p \cdot x - 12 = 0$ be a quadratic equation.

Task:

Determine the value of p for which the equation has the solution set $L = \{-2, 6\}$.

Task 5

Addition of Vectors

The diagram below shows two vectors \vec{v}_1 and \vec{v} .

Task:

On the diagram below, draw a third vector, \vec{v}_2 , such that $\vec{v}_1 + \vec{v}_2 = \vec{v}$.

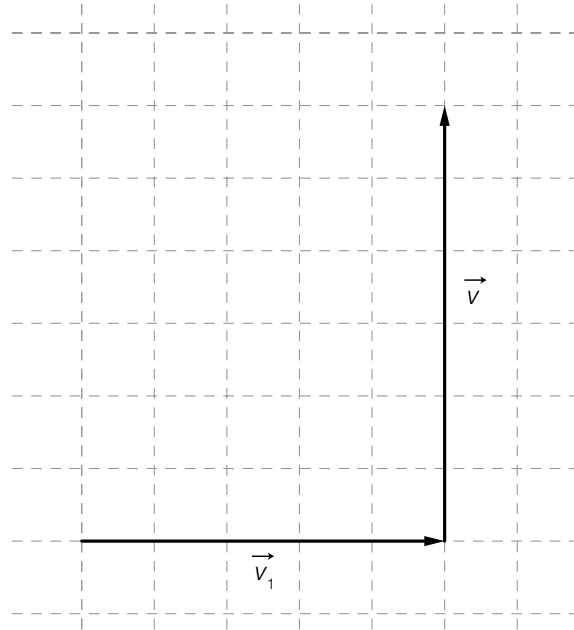

Task 6

Measuring an Inaccessible Steep Wall

A section of a steep wall, CD , is inaccessible. It has a height of $h = \overline{CD}$. To be able to determine the height of the section of the wall, the angles $\alpha = 24^\circ$ and $\beta = 38^\circ$ and the distance $e = 6$ metres were measured. The situation is represented in the diagram below. The diagram is not to scale.

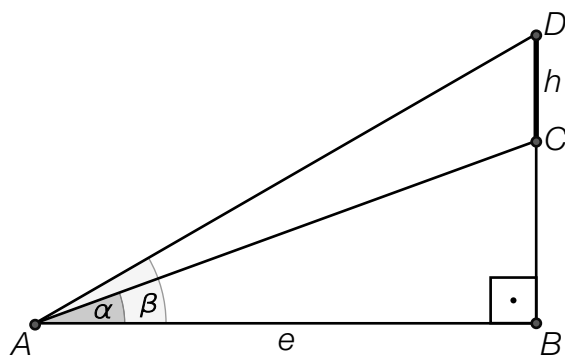

Task:

Calculate the height, h , of the inaccessible section of the steep wall in metres.

Task 7

Recognising the Properties of a Function

Below you will find a diagram of a third degree polynomial function, f .

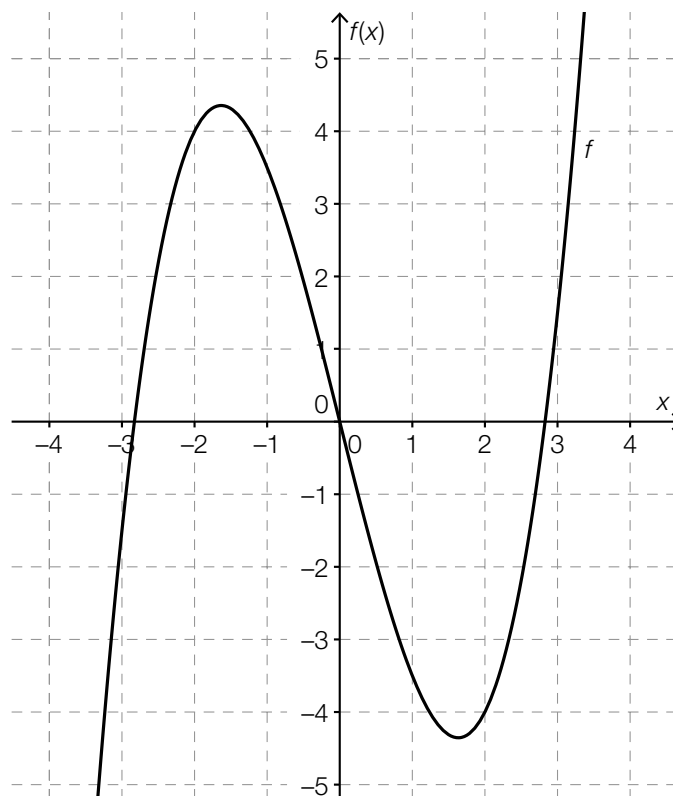

Task:

Put a cross next to the true statement(s) about the graph of f .

The function f is monotonically increasing in the interval $(2, 3)$.	<input type="checkbox"/>
The function f has a local maximum in the interval $(1, 2)$.	<input type="checkbox"/>
The concavity of the function f changes in the interval $(-1, 1)$.	<input type="checkbox"/>
The graph of f is symmetrical about the vertical axis.	<input type="checkbox"/>
The monotonicity of the function changes in the interval $(-3, 0)$.	<input type="checkbox"/>

Task 8

Cost, Revenue and Profit

The function E describes the revenue (in €) that is generated from the sale of x units of a product. The function G describes the corresponding profit in €. This is defined as the difference “revenue – costs”.

Task:

Complete the diagram below by drawing the graph of the corresponding cost function, K . Assume that K is linear. (The model in this task assumes that all manufactured products are sold.)

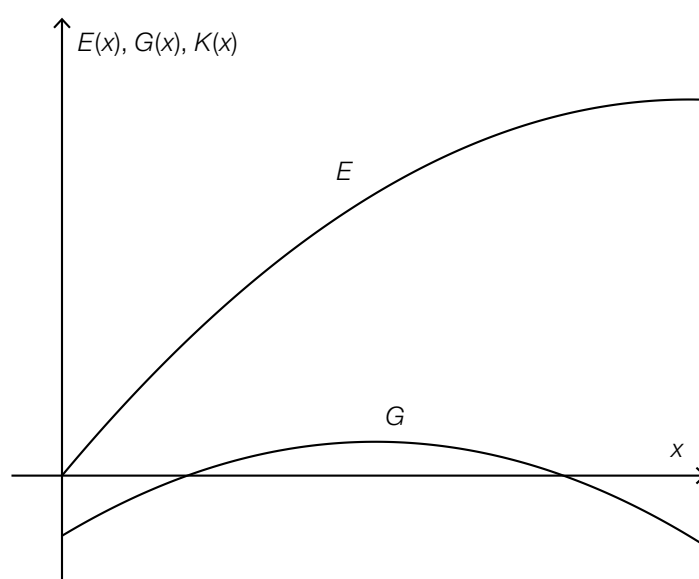

Task 9

Heating Water

During an experiment, a specified amount of water is warmed in a microwave for a time t . The energy level of the microwave remains constant during the experiment. The initial temperature of the water and its temperature after 30 seconds are measured.

Time (in seconds)	$t = 0$	$t = 30$
Temperature (in °C)	35.6	41.3

Task:

Complete the equation of the corresponding linear function that gives the temperature $T(t)$ at time t .

$$T(t) = \underline{\hspace{2cm}} \cdot t + 35.6$$

Task 10

Power Functions

The graphs of four different power functions, f , where $f(x) = a \cdot x^z$, are shown below along with six conditions for the parameter a and the exponent z . The parameter a is a real number, and the exponent z is a natural number.

Task:

Match each of the four graphs with the corresponding conditions for the parameter a and the exponent z of the equation of the function (from A to F).

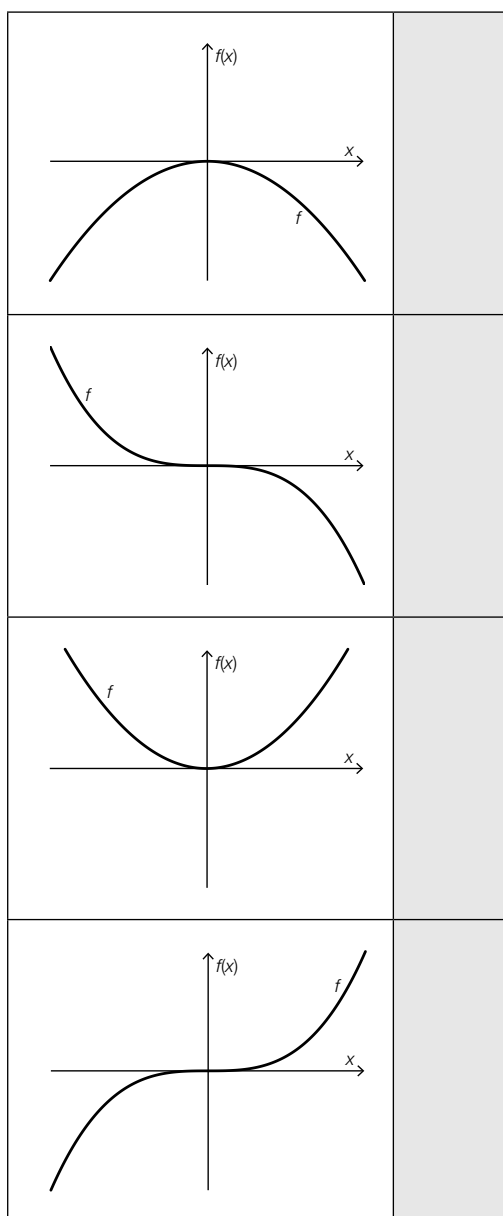

A	$a > 0, z = 1$
B	$a > 0, z = 2$
C	$a > 0, z = 3$
D	$a < 0, z = 1$
E	$a < 0, z = 2$
F	$a < 0, z = 3$

Task 11

Expansion of an Oil Slick

The area of an oil slick is currently 1.5 km^2 , and it is expanding at a rate of 5 % per day.

Task:

Determine the number of days after which the oil slick is larger than 2 km^2 for the first time.

Task 12

Parameters of Exponential Functions

The diagram below shows the graphs of two exponential functions, f and g , with equations $f(x) = c \cdot a^x$ and $g(x) = d \cdot b^x$, where $a, b, c, d \in \mathbb{R}^+$.

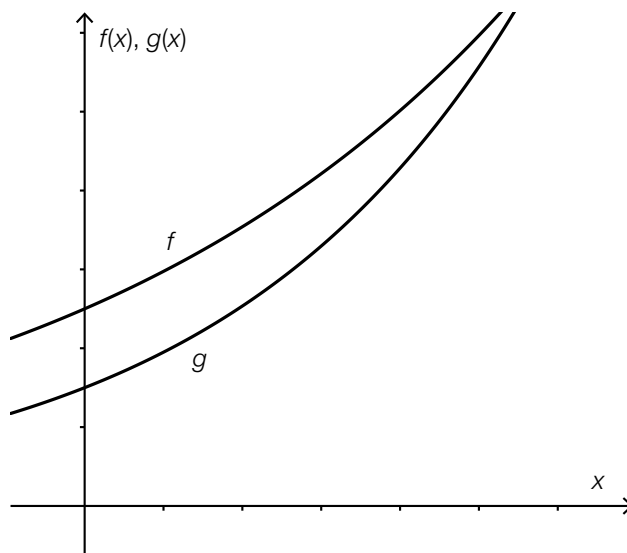

Task:

Complete the following sentence by putting a cross next to one of the given possibilities for each gap so that the sentence becomes a correct statement.

For the parameters a, b, c, d of the two exponential functions given above, the relationships ① and ② hold.

①	
$c < d$	<input type="checkbox"/>
$c = d$	<input type="checkbox"/>
$c > d$	<input type="checkbox"/>

②	
$a < b$	<input type="checkbox"/>
$a = b$	<input type="checkbox"/>
$a > b$	<input type="checkbox"/>

Task 13

Interpreting the Average Rate of Change

Let f be a third degree polynomial function. The average rate of change of f in the interval $[x_1, x_2]$ is 5.

Task:

Which of the following statements are definitely true for the function f ?
Put a cross next to each of the two correct statements.

In the interval $[x_1, x_2]$ there is at least one point x for which $f(x) = 5$.	<input type="checkbox"/>
$f(x_2) > f(x_1)$	<input type="checkbox"/>
The function f is monotonically increasing in the interval $[x_1, x_2]$.	<input type="checkbox"/>
$f'(x) = 5$ for all $x \in [x_1, x_2]$	<input type="checkbox"/>
$f(x_2) - f(x_1) = 5 \cdot (x_2 - x_1)$	<input type="checkbox"/>

Task 14

Savings Account

Mrs. Fröhlich has a savings account in which she deposits the same amount of money in euros on the first working day of each year. On this day her bank also credits the account with the interest earned over the previous year. Afterwards, the new statement showing the balance of the account is printed.

The relationship between the balance from the previous year, K_{i-1} , and the balance of the current year, K_i , can be described by the following formula:

$$K_i = 1.03 \cdot K_{i-1} + 5000$$

Task:

Based on the information given above, which of the following statements are correct?
Put a cross next to each of the two correct statements.

Mrs. Fröhlich pays € 5,000 a year into her savings account.	<input type="checkbox"/>
The balance of the savings account increases by € 5,000 per year.	<input type="checkbox"/>
The relative annual growth of the balance of the savings account is larger than 3 %.	<input type="checkbox"/>
The difference between the balances of two consecutive years is always the same.	<input type="checkbox"/>
The balance of the savings account increases at a linear rate.	<input type="checkbox"/>

Task 15

Functions and Derivatives

The graphs of four polynomial functions (f_1, f_2, f_3, f_4) are shown on the left and the graphs of six more functions ($g_1, g_2, g_3, g_4, g_5, g_6$) are shown on the right.

Task:

Match each of the polynomial functions, f_1 to f_4 , to its corresponding derivative g_1 to g_6 (from A to F).

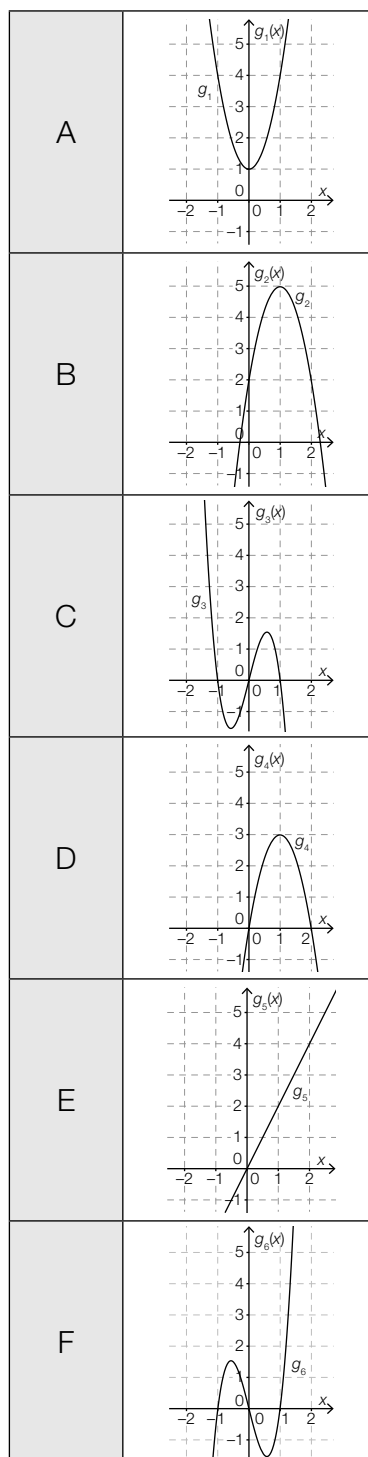
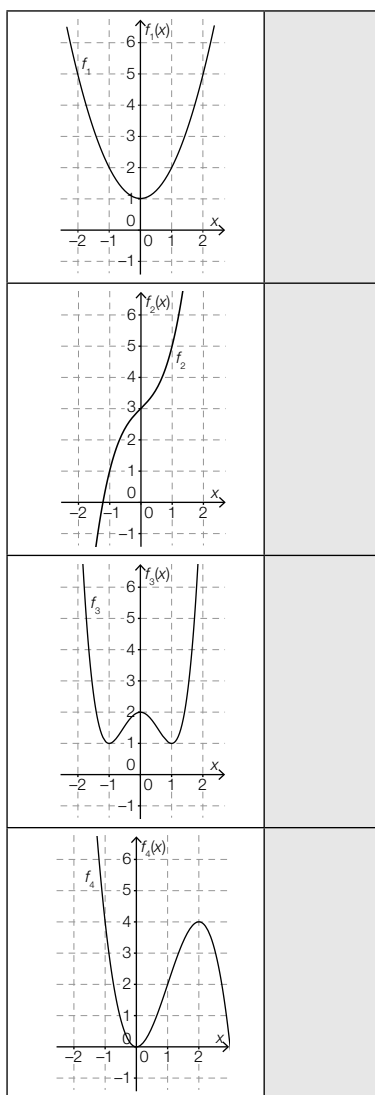

Task 16

Local Minimum

Let p be a polynomial function with $p(x) = x^3 - 3 \cdot x + 2$. The first derivative p' , where $p'(x) = 3 \cdot x^2 - 3$, has the value zero at the point where $x = 1$.

Task:

Demonstrate by means of calculation that p has a local minimum at this point (i. e. that the graph of p has a local minimum there).

Task 17

Work Done in Moving a Body

A body is moved in a straight line under the influence of a force. The required component of the force in the direction of motion as a function of the distance covered is shown in the diagram below. The distance, s , is measured in metres, and the force, $F(s)$, is measured in Newtons (N).

In the first section, $F(s)$ is described by f_1 , where $f_1(s) = \frac{5}{16} \cdot s^2$. In the second section (f_2), the value decreases in a linear way until it reaches 0.

The points on the graph shown in bold have integer coordinates.

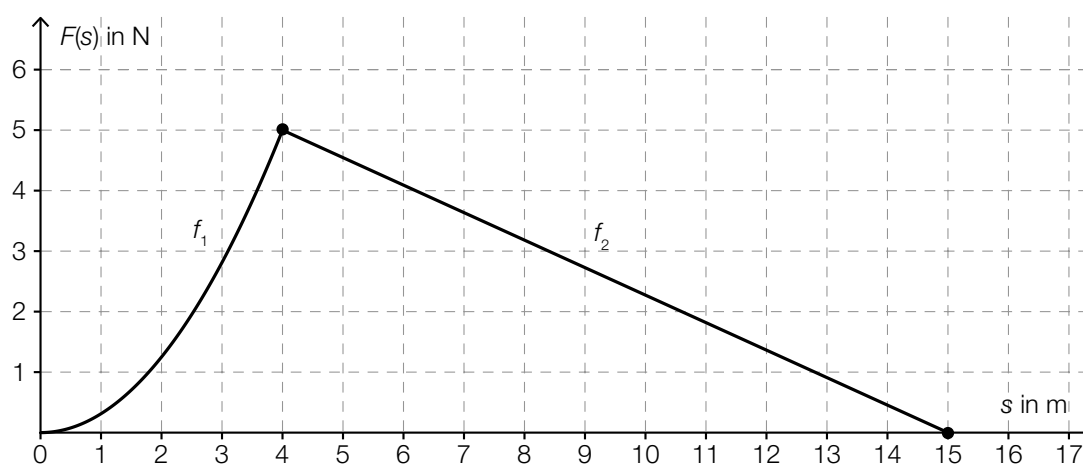

Task:

Determine the work done, W , in joules (J), that this force exerts on the body if it is moved from $s = 0$ m to $s = 15$ m.

$W =$ _____ J

Task 18

Integral

Let f be a power function, where $f(x) = x^3$.

Task:

Determine the values of the boundary conditions b and c ($b \neq c$) such that $\int_b^c f(x) dx = 0$ holds.

Task 19

Truck Loads

During a traffic inspection, the loads carried by trucks were checked. 140 of the trucks checked were overloaded. Details of the check are summarised in the table below.

Excess load (E) in tonnes	$E < 1\text{t}$	$1\text{t} \leq E < 3\text{t}$	$3\text{t} \leq E < 6\text{t}$
Number of trucks	30	50	60

Task:

Represent the data in the table above as a histogram. The absolute frequencies should be represented by the areas of rectangles.

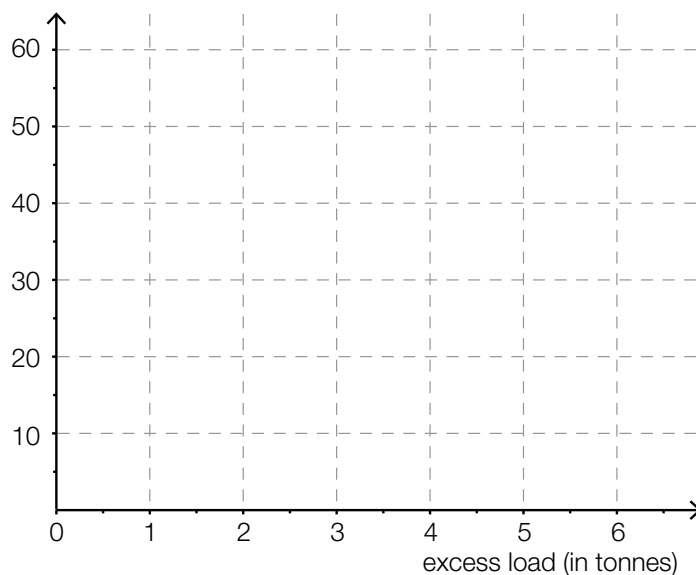

Task 20

Ice Hockey Goals

The results of all games played in the Austrian Ice Hockey League are evaluated statistically. In the 2012/13 season, the number of games in which a particular number of goals were scored over a determined period of time was counted. The bar chart below shows the results of the evaluation.

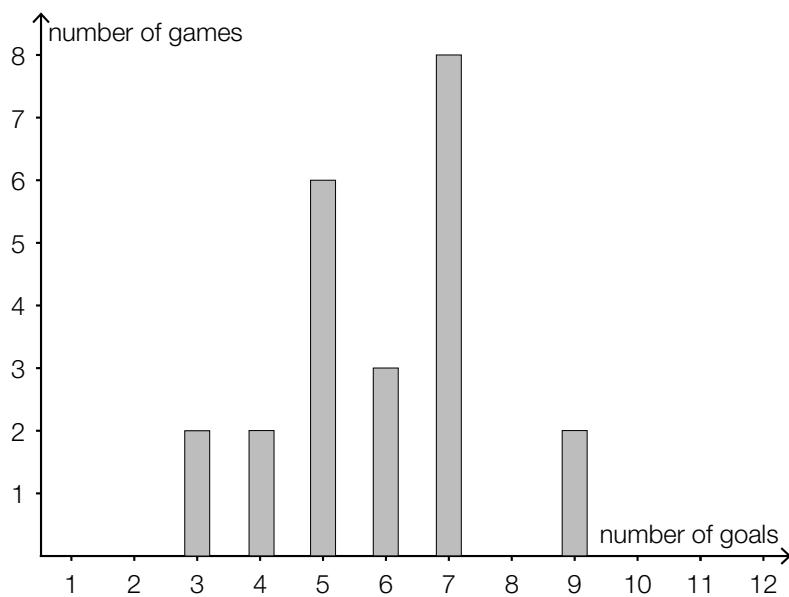

Task:

Using the bar chart, determine the median value of this data set.

Task 21

Customs Check

A group of ten people are crossing a border between two countries. Two people have contraband items with them. While crossing the border three members of the group are randomly selected and checked by customs officials.

Task:

Determine the probability that both of the two smugglers happen to be in the selected group of the three people to be checked.

Task 22

Probability Distribution

The range of values of a random variable X is comprised of the values x_1, x_2, x_3 .

The probability $P(X = x_1) = 0.4$ is known. Also, it is known that x_3 is twice as likely to occur as x_2 .

Task:

Determine $P(X = x_2)$ and $P(X = x_3)$.

$$P(X = x_2) = \underline{\hspace{10cm}}$$

$$P(X = x_3) = \underline{\hspace{10cm}}$$

Task 23

Coloured Balls

There is a box on a table with three red and twelve black balls inside. Three balls are randomly selected and removed from the box one after the other. After each ball has been selected, it is placed back into the box.

Task:

Consider the following expression:

$$3 \cdot 0.8^2 \cdot 0.2$$

Put a cross next to the event whose probability can be calculated with this expression.

At most one black ball is selected.	<input type="checkbox"/>
Exactly two black balls are selected.	<input type="checkbox"/>
Two red balls and one black ball are selected.	<input type="checkbox"/>
Only red balls are selected.	<input type="checkbox"/>
At least one red ball is selected.	<input type="checkbox"/>
No red balls are selected.	<input type="checkbox"/>

Task 24

Comparison of Two Confidence Intervals

Based on a random sample of size n_1 , an opinion research institute gives the confidence interval of the current share of the vote of a political party as $[0.23, 0.29]$. The corresponding confidence level is γ_1 .

A different institute asks n_2 randomly chosen eligible voters and gives the according confidence interval $[0.24, 0.28]$ at a confidence level of γ_2 . Both institutes use the same method of calculation.

Task:

Complete the following sentence by putting a cross next to one of the given possibilities for each gap, so that the sentence becomes a correct statement.

Given that $n_1 = n_2$, it can be concluded that _____ ① _____;
 given that $\gamma_1 = \gamma_2$, it can be concluded that _____ ② _____.

①	
$\gamma_1 < \gamma_2$	<input type="checkbox"/>
$\gamma_1 = \gamma_2$	<input type="checkbox"/>
$\gamma_1 > \gamma_2$	<input type="checkbox"/>

②	
$n_1 < n_2$	<input type="checkbox"/>
$n_1 = n_2$	<input type="checkbox"/>
$n_1 > n_2$	<input type="checkbox"/>

Task 1

Properties of Numbers

Below you will find statements about numbers and sets of numbers.

Task:

Put a cross next to each of the two correct statements.

The square root of every natural number is an irrational number.	<input type="checkbox"/>
Every natural number can be written as a fraction in the form $\frac{a}{b}$ where $a \in \mathbb{Z}$ and $b \in \mathbb{Z} \setminus \{0\}$.	<input type="checkbox"/>
The product of two rational numbers can be a natural number.	<input type="checkbox"/>
Every real number can be written as a fraction in the form $\frac{a}{b}$ where $a \in \mathbb{Z}$ and $b \in \mathbb{Z} \setminus \{0\}$.	<input type="checkbox"/>
There exists a smallest integer.	<input type="checkbox"/>

Task 2

System of Equations

Below you will see a system of linear equations involving the variables $x, y \in \mathbb{R}$:

$$\text{I: } x + 4 \cdot y = -8$$

$$\text{II: } a \cdot x + 6 \cdot y = c \text{ where } a, c \in \mathbb{R}$$

Task:

Determine the values for a and c for which the system of equations has infinitely many solutions.

$$a = \underline{\hspace{10cm}}$$

$$c = \underline{\hspace{10cm}}$$

Task 3

Vectors

In two-dimensional space, the points A , B , C and D are marked on a straight line at equal intervals.

Thus:

$$\vec{AB} = \vec{BC} = \vec{CD}$$

The coordinates of the points A and C are as follows:

$$A = (3, 1)$$

$$C = (7, 8)$$

Task:

Determine the coordinates of D .

$$D = (\quad, \quad)$$

Task 4

Equation of a Line

The line g is represented by the vector equation $g: X = \begin{pmatrix} 2 \\ 6 \end{pmatrix} + t \cdot \begin{pmatrix} 3 \\ -5 \end{pmatrix}$.

Task:

Write down possible values for a and b such that the line h , with equation $a \cdot x + b \cdot y = 1$, is perpendicular to line g .

$a =$ _____

$b =$ _____

Task 5

Upwarp of Lake Constance

Due to the curvature of the Earth, the surface of Lake Constance is curved. The Earth can be modelled as a sphere with radius $R = 6370$ km and midpoint M . The size of the angle $\varphi = 0.5846^\circ$ can be determined from the length of the southeast-northwest span of Lake Constance. Using this information, the height of the upwarp of Lake Constance can be approximated.

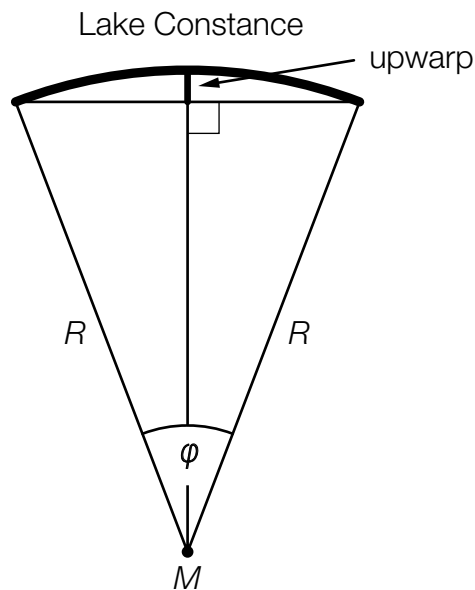

Task:

Determine the height of the upwarp of Lake Constance (see diagram above) in metres.

Upwarp: _____ meters

Task 6

Determining an Angle

An angle $\alpha \in [0^\circ, 360^\circ)$ fulfils the following criteria:

$$\sin(\alpha) = 0.4 \quad \text{and} \quad \cos(\alpha) < 0$$

Task:

Determine the size of the angle α .

Task 7

Reading Data from a Diagram

A motorbike travels along the same stretch of road (560 km) as a car. Both journeys are modelled as straight lines on the distance-time-diagram shown below. The points marked in bold have integer coordinates.

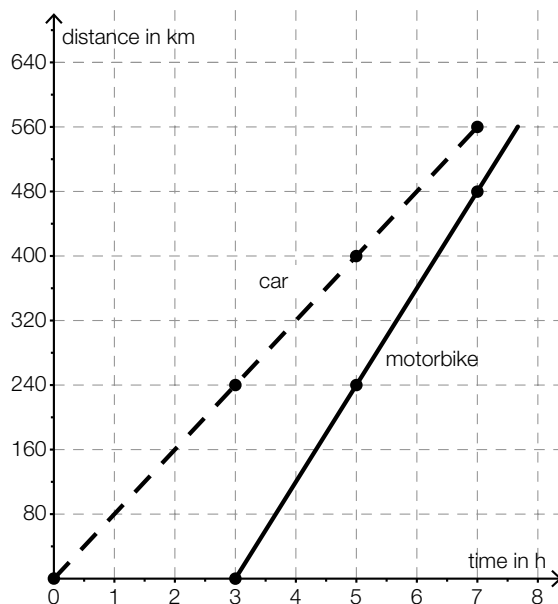

Task:

Put a cross next to each of the two statements below that give a correct interpretation of the diagram.

The motorbike sets off three hours after the car leaves.	<input type="checkbox"/>
The motorbike has an average speed of 100 km/h.	<input type="checkbox"/>
When the car reaches its destination, the motorbike is still 120 km away from it.	<input type="checkbox"/>
The average speed of the car is 40 km/h less than that of the motorbike.	<input type="checkbox"/>
The motorbike's total travel time for this section of the road is longer than that of the car.	<input type="checkbox"/>

Task 8

Graphs and Types of Functions

The graphs of four functions as well as the equations of six types of functions with parameters $a, b \in \mathbb{R}^+$ are shown below.

Task:

Match each of the four graphs to its corresponding type of function (from A to F).

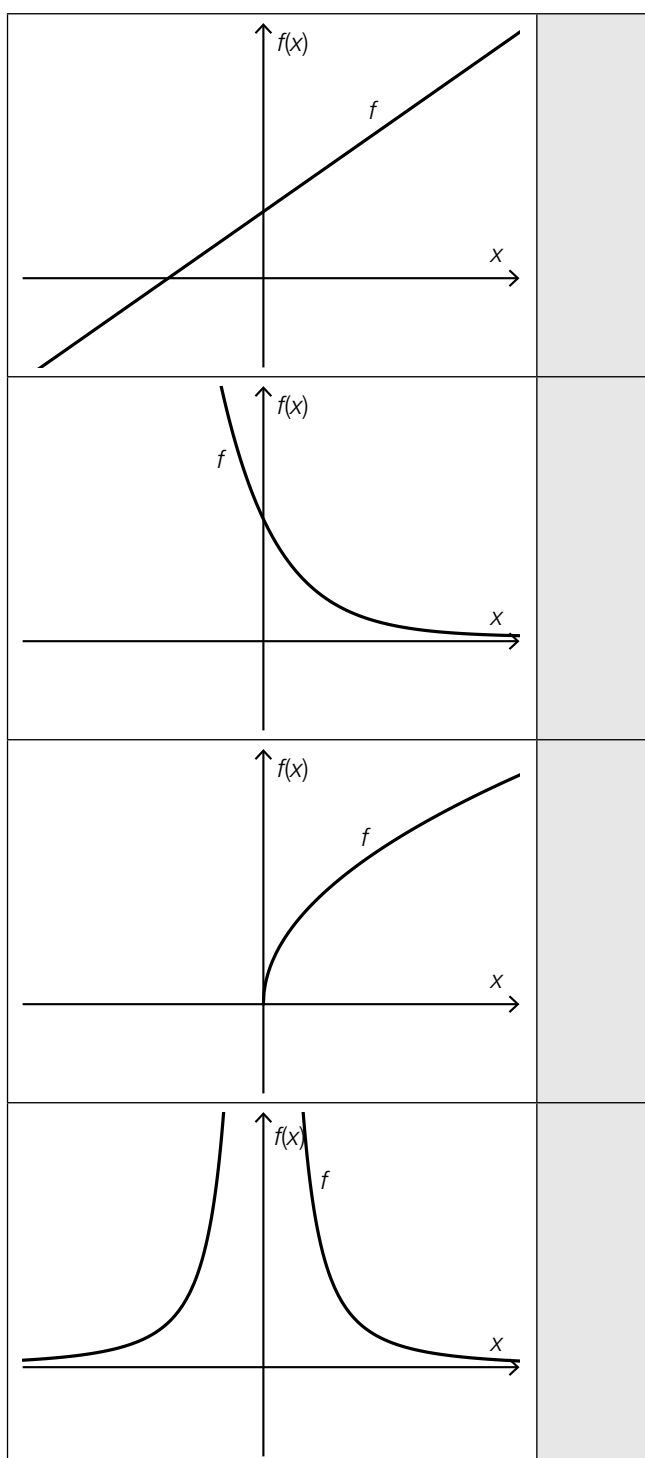

A	$f(x) = a \cdot b^x$
B	$f(x) = a \cdot x^{\frac{1}{2}}$
C	$f(x) = a \cdot \frac{1}{x^2}$
D	$f(x) = a \cdot x^2 + b$
E	$f(x) = a \cdot x^3$
F	$f(x) = a \cdot x + b$

Task 9

Equation of a Linear Function

A linear function f has the following properties:

- If the argument, x , is increased by 2, then the function value $f(x)$ decreases by 4.
- $f(0) = 1$

Task:

Determine the equation of this linear function f .

$f(x) =$ _____

Task 10

n^{th} Degree Polynomial Function

The diagram below shows the graph of a polynomial function f . All of the characteristic points of the graph (axis intercepts, maxima and minima, points of inflexion) are included on the diagram.

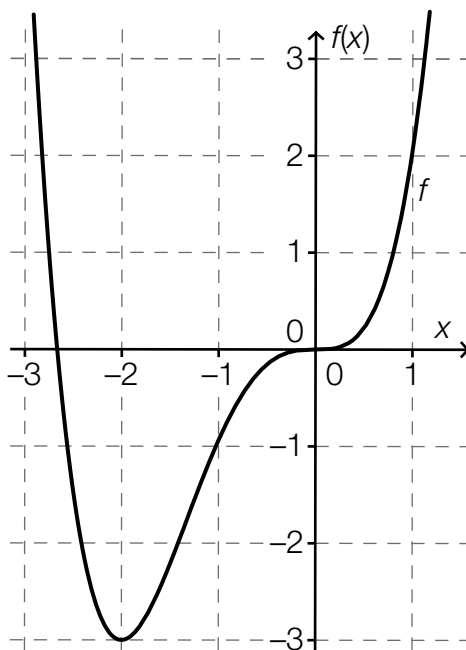

Task:

Complete the following sentence by putting a cross next to one of the given possibilities for each gap so that the sentence becomes a correct statement.

The polynomial function f has degree $\text{\textcircled{1}}$ because f has exactly $\text{\textcircled{2}}$.

$\text{\textcircled{1}}$	
$n < 3$	<input type="checkbox"/>
$n = 3$	<input type="checkbox"/>
$n > 3$	<input type="checkbox"/>

$\text{\textcircled{2}}$	
one maximum or minimum	<input type="checkbox"/>
two points of inflection	<input type="checkbox"/>
two roots	<input type="checkbox"/>

Task 11

Bee Population

Due to environmental poisoning, a beekeeper's population of bees is declining daily by a fixed percentage. The beekeeper has determined that he has suffered a loss of 50 % of the population within 14 days.

Task:

Determine the daily relative population decrease in percent.

Daily relative population decrease: _____ %

Task 12

Periodic Function

A periodic function f has equation $f(x) = \sin(x)$.

Task:

Determine the smallest value $a > 0$ (measured in radians) such that the equation $f(x + a) = f(x)$ holds for all $x \in \mathbb{R}$.

$a =$ _____ rad

Task 13

Share Price

From the time $t = 0$ the price of a share (in euros) is observed and recorded. The price of the share after t days is given by $A(t)$.

Task:

The following value is calculated:

$$\frac{A(10) - A(0)}{10} = 2$$

Write down what this value represents in the context of the development of the price of the share.

Task 14

Differentiation Rules

It is known that $g(x) = 3 \cdot f(x) - 2$ holds for the polynomial functions f and g for all $x \in \mathbb{R}$.

Task:

Which of the statements below is true for all $x \in \mathbb{R}$? Put a cross next to the correct statement.

$g'(x) = f'(x)$	<input type="checkbox"/>
$g'(x) = f'(x) - 2$	<input type="checkbox"/>
$g'(x) = 3 \cdot f'(x)$	<input type="checkbox"/>
$g'(x) = 3 \cdot f'(x) - 2$	<input type="checkbox"/>
$g'(x) = 3 \cdot f'(x) - 2 \cdot x$	<input type="checkbox"/>
$g'(x) = -2 \cdot f'(x)$	<input type="checkbox"/>

Task 15

Graphs of Derivatives

In the diagrams below the graphs of the functions f , g and h are shown.

Task:

In one of the six diagrams, g is the first derivative of f and h is the second derivative of f . Put a cross next to this diagram.

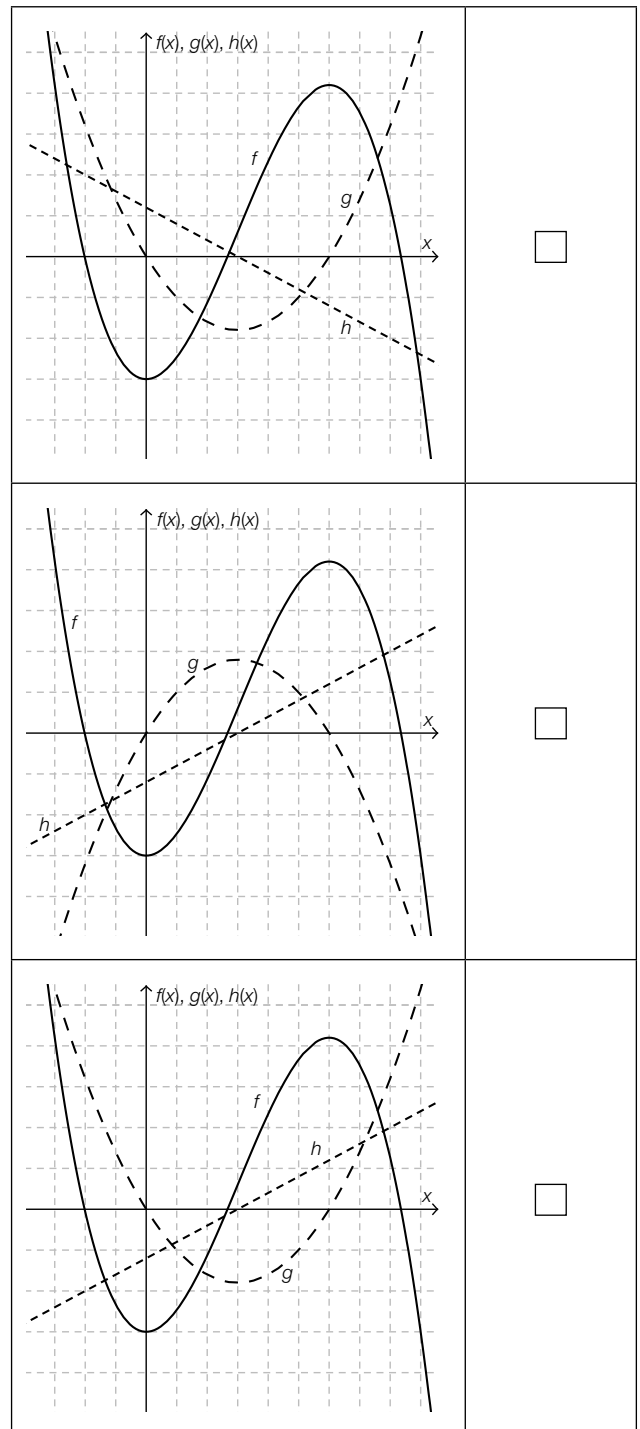
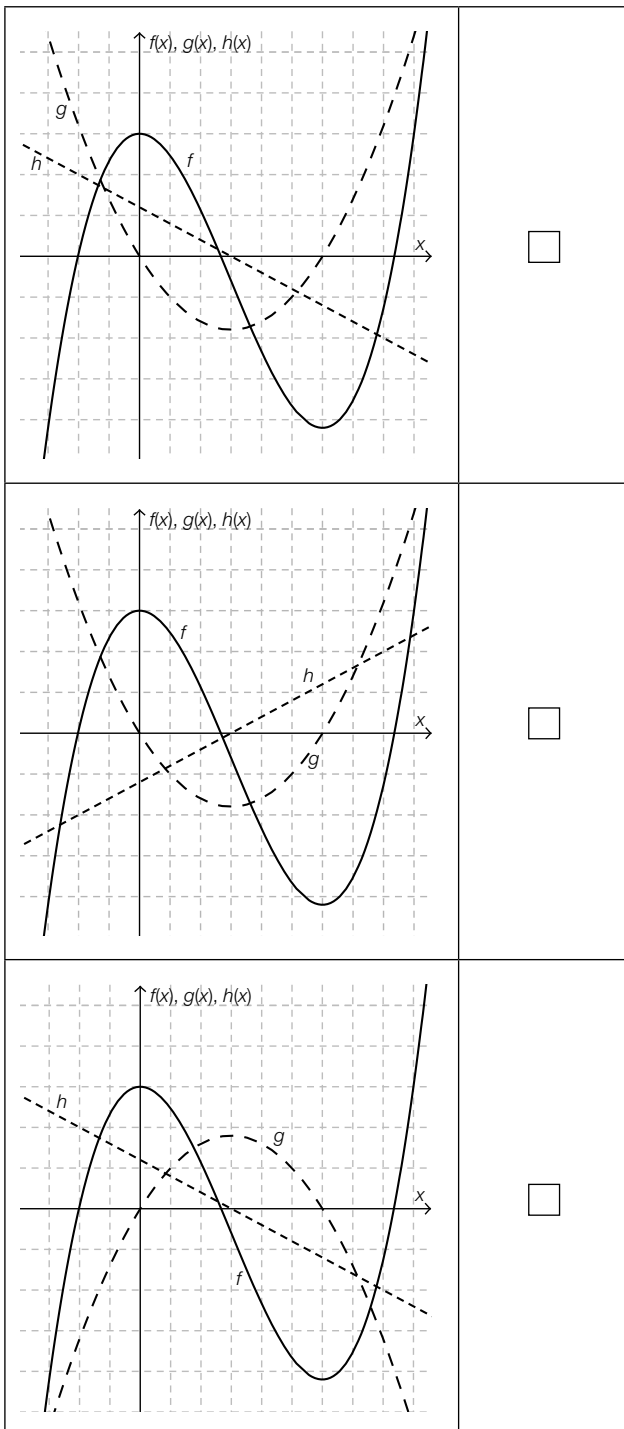

Task 16

Differentiable Function

The diagram below shows a section of a graph of a polynomial function f . The gradient of the tangent is steepest at the point where $x = 6$.

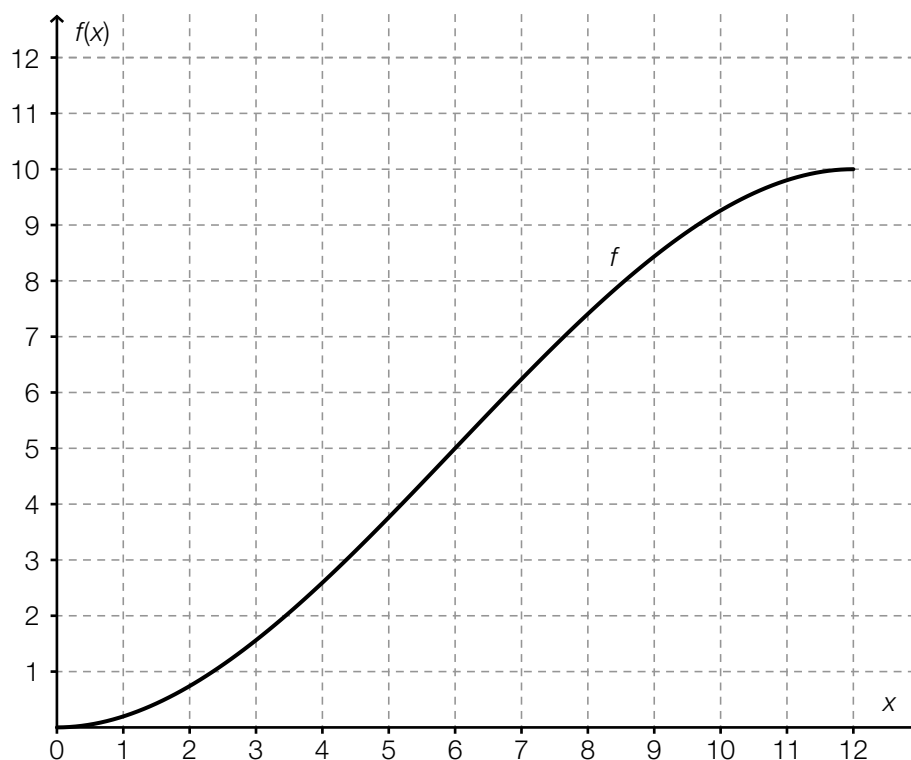

Task:

Put a cross next to each of the two correct statements about the function f .

$f''(6) = 0$	<input type="checkbox"/>
$f''(11) < 0$	<input type="checkbox"/>
$f''(2) < f''(10)$	<input type="checkbox"/>
$f'(6) = 0$	<input type="checkbox"/>
$f'(7) < f'(10)$	<input type="checkbox"/>

Task 17

Integral

The definite integral I is given by $I = \int_0^a (25 \cdot x^2 + 3) dx$ where $a \in \mathbb{R}^+$.

Task:

Put a cross next to each of the two expressions that have the same value as I for all $a > 0$.

$25 \cdot \int_0^a x^2 dx + \int_0^a 3 dx$	<input type="checkbox"/>
$\int_0^a 25 dx \cdot \int_0^a x^2 dx + \int_0^a 3 dx$	<input type="checkbox"/>
$\int_0^a 25 \cdot x^2 dx + 3$	<input type="checkbox"/>
$\frac{25 \cdot a^3}{3} + 3 \cdot a$	<input type="checkbox"/>
$50 \cdot a$	<input type="checkbox"/>

Task 18

Bisecting an Area

The real function f is given by the equation $f(x) = x^2$.

Task:

Determine the x -coordinate b such that the area between the x -axis and the graph of the function f in the interval $[2, 4]$ is divided into two areas of equal size, A_1 and A_2 (see diagram below).

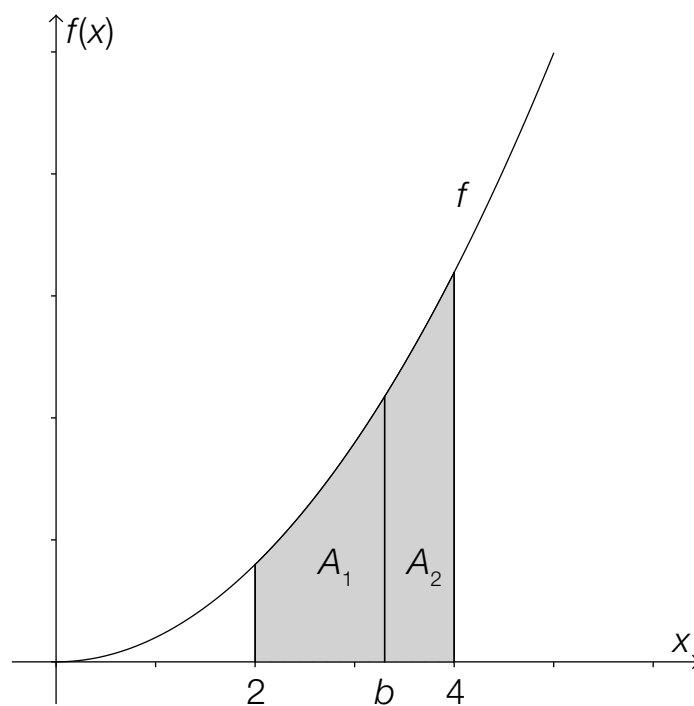

Task 19

Convictions of Juveniles

According to the Youth Protection Act of 1988 (version as of 23.03.2016), juveniles are classed as people who are aged between 14 and 17 inclusive. The diagram below shows the absolute number of convictions of juveniles as well as the number of convictions per 100 000 juveniles from 1950 to 2010.

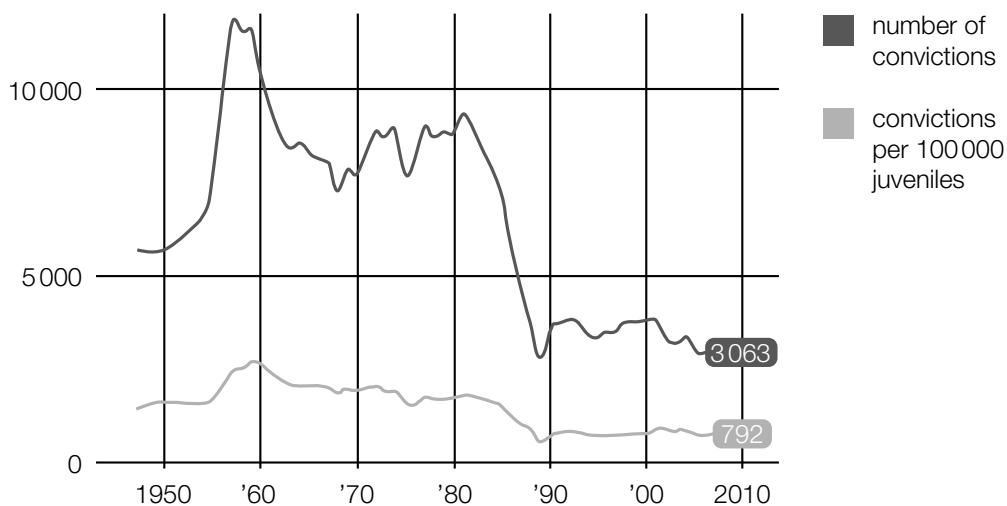

Data source: <http://derstandard.at/1371171382188/Jugendkriminalitaet-auf-Rekordtief> [04.07.2013].

Task:

Approximately how many juveniles were there in total in Austria in the year 2010?
Put a cross next to the correct number.

792 000	<input type="checkbox"/>
3 063 000	<input type="checkbox"/>
3 863 000	<input type="checkbox"/>
387 000	<input type="checkbox"/>
258 000	<input type="checkbox"/>
2 580 000	<input type="checkbox"/>

Task 20

Probability of the Birth of a Girl

In 2014, of the children born in Austria, 42 162 were boys and 39 560 were girls.

Task:

From this data, determine an approximate value for the probability that a child born in Austria is a girl.

Task 21

Entrance Check

Whilst entering a sporting event a person P is carrying a prohibited item. During a security check, prohibited items are discovered with a probability of 0.9. As this sporting event is particularly high-risk, each person must undergo such two independent security checks.

Task:

Determine the probability that person P 's prohibited item will be discovered by the security checks.

Task 22

Random Variable

Below you will see the six faces of a fair dice. On each face, three symbols are shown. (A dice is considered to be "fair" if the probability of the dice showing any of its six faces after being thrown is equal for all six faces.)

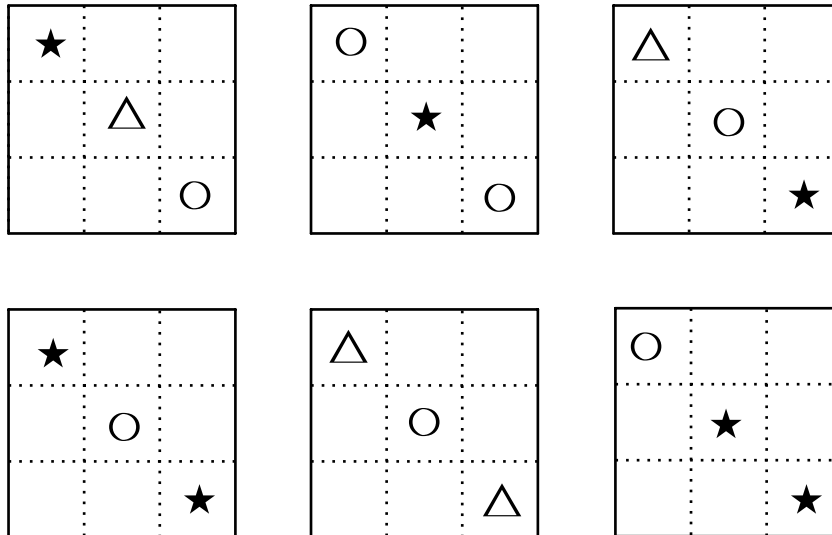

Task:

In a trial the dice is thrown once. The random variable X represents the number of stars on the face facing upwards. Determine the probability distribution of X , i. e. the possible values of X and their corresponding probabilities.

Task 23

Parameter of a Binomial Distribution

An experiment is described by a binomially distributed random variable X . This random variable has a probability of success of $p = 0.36$ and the standard deviation $\sigma = 7.2$.

Task:

Determine the corresponding parameter n (the number of trials).

$n =$ _____

Task 24

500 Euro Notes in Austria

In a representative survey in Austria, participants were asked for their opinions about the elimination of 500 euro notes. Of the people asked, 234 out of 1 000 participants were for the elimination of 500 euro notes.

Task:

Determine a symmetrical 95 % confidence interval for the relative proportion of Austrians who support the elimination of 500 euro notes.

Task 1

Value Added Tax for Audio Books

Since 2015, certain audio books in Germany have been taxed at a reduced rate of 7 % Value Added Tax (VAT) instead of 19 %.

Task:

Suggest a formula to calculate the reduced price € y of an audio book including 7 % VAT, that originally cost € x including 19 % VAT.

Task 2

Quadratic Equation

A quadratic equation is given by $a \cdot x^2 + 10 \cdot x + 25 = 0$ where $a \in \mathbb{R}$, $a \neq 0$.

Task:

Determine the value(s) of a for which the equation has exactly one real solution.

$a =$ _____

Task 3

Dividing a Line Segment

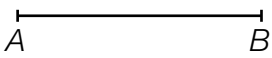
The line segment AB :  is internally split at the point T at a ratio of 3:2.

Task:

Write down a formula to calculate the point T .

$T =$ _____

Task 4

Trapezium

The coordinates of the vertices of a trapezium $ABCD$ are:

$$A = (2, -6)$$

$$B = (10, -2)$$

$$C = (9, 2)$$

$$D = (3, y)$$

The sides $a = AB$ and $c = CD$ are parallel.

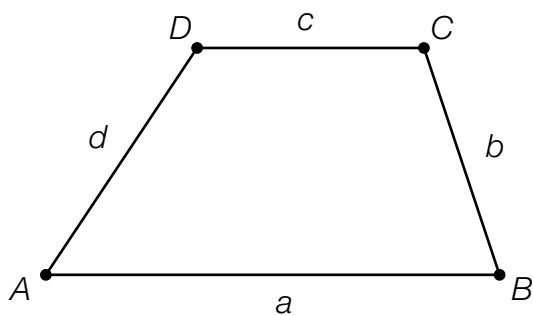

Task:

Determine the value of the coordinate y of the point D .

$y =$ _____

Task 5

Parallel Lines

The line g has vector equation $g: X = \begin{pmatrix} 1 \\ -2 \end{pmatrix} + s \cdot \begin{pmatrix} 2 \\ 3 \end{pmatrix}$.

The line h is parallel to g and goes through the origin.

Task:

Determine the equation of the line h in the form $a \cdot x + b \cdot y = c$ where $a, b, c \in \mathbb{R}$.

h : _____

Task 6

Rhombus

In a rhombus of side length a , the diagonals $e = \overline{AC}$ and $f = \overline{BD}$ bisect one another. The diagonal e bisects the angle $\alpha = \sphericalangle DAB$ and the diagonal f bisects the angle $\beta = \sphericalangle ABC$.

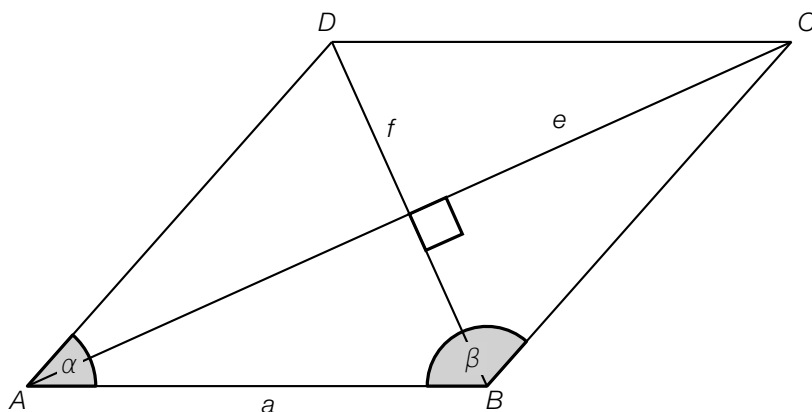

Task:

The side length a and angle β are known.

Write down a formula to calculate f in terms of a and β .

$f =$ _____

Task 7

Point of Intersection

The function E describes the revenue, $E(x)$, and the function K the costs, $K(x)$, in euros for a production volume x . The production volume x is given in units of quantity (ME). The graphs of both functions are represented in the diagram below:

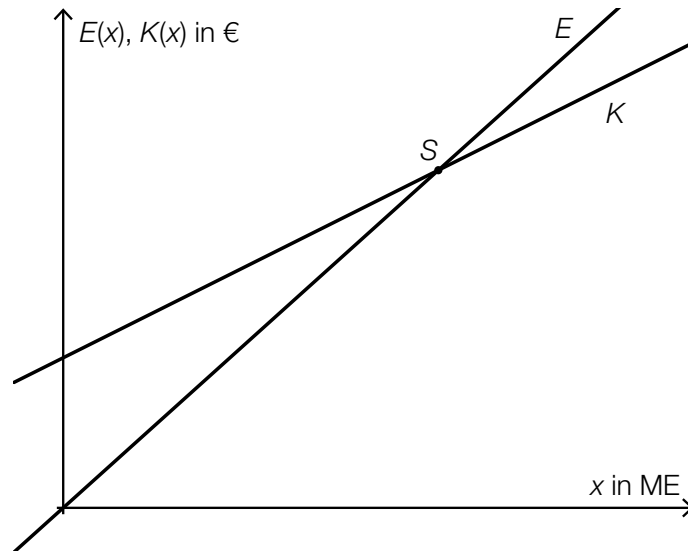

Task:

Interpret both of the coordinates of the point of intersection S of the graphs of the functions in the given context.

Task 8

Increasing Function

Below, you will see five functions.

Task:

Which of the functions f below are strictly monotonically increasing in each interval $[x_1, x_2]$ where $0 < x_1 < x_2$? Put a cross next to each of the two correct functions.

A linear function f with equation $f(x) = a \cdot x + b$ ($a > 0, b > 0$)	<input type="checkbox"/>
A power function f with equation $f(x) = a \cdot x^n$ ($a < 0, n \in \mathbb{N}, n > 0$)	<input type="checkbox"/>
A sine function f with equation $f(x) = a \cdot \sin(b \cdot x)$ ($a > 0, b > 0$)	<input type="checkbox"/>
An exponential function f with equation $f(x) = a \cdot e^{k \cdot x}$ ($a > 0, k < 0$)	<input type="checkbox"/>
An exponential function f with equation $f(x) = c \cdot a^x$ ($a > 1, c > 0$)	<input type="checkbox"/>

Task 9

Electric Resistance

The electric resistance R of a cylindrical conductor with radius r and length l can be calculated using the formula $R = \rho \cdot \frac{l}{r^2 \cdot \pi}$. The size of the specific resistivity, ρ , is dependent on the material and temperature of the conductor.

Task:

In the table below, relationships that can be derived from the formula for electric resistance are shown.

Which of the equations listed below describe(s) a linear function? Put a cross next to each of the correct equations.

$R(l) = \rho \cdot \frac{l}{r^2 \cdot \pi}$ where ρ, r constant	<input type="checkbox"/>
$l(R) = \frac{R}{\rho} \cdot r^2 \cdot \pi$ where ρ, r constant	<input type="checkbox"/>
$R(\rho) = \rho \cdot \frac{l}{r^2 \cdot \pi}$ where l, r constant	<input type="checkbox"/>
$R(r) = \rho \cdot \frac{l}{r^2 \cdot \pi}$ where ρ, l constant	<input type="checkbox"/>
$l(r) = \frac{R}{\rho} \cdot r^2 \cdot \pi$ where R, ρ constant	<input type="checkbox"/>

Task 10

Function

The diagram below shows the graph of a function f where $f(x) = a \cdot x^{\frac{1}{2}} + b$ ($a, b \in \mathbb{R}, a \neq 0$). The points shown in bold have integer coordinates.

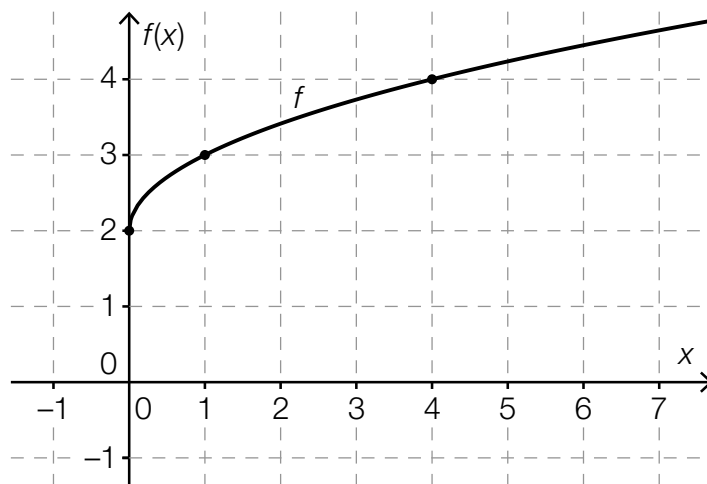

Task:

Determine the values of a and b .

$a =$ _____

$b =$ _____

Task 11

Population Growth

The size of a population can be described dependant of the time by a function N , where $N(t) = N_0 \cdot e^{0.1188 \cdot t}$. The time, t , is measured in hours. In this function, N_0 represents the size of the population at time $t = 0$ and $N(t)$ the size of the population at the time $t \geq 0$.

Task:

Determine the percentage p by which the population increases per hour.

$p \approx$ _____ %

Task 12

Trigonometric Functions

Let f and g be functions where $f(x) = -\sin(x)$ and $g(x) = \cos(x)$.

Task:

Determine the value $b \in [0, 2\pi]$ by which the graph of f would need to be translated to be identical to the graph of g , i. e. so that $-\sin(x + b) = \cos(x)$ holds.

Task 13

Fertility

On the Statistik Austria website, the following information can be found under the heading Fertility:

“The total fertility rate in 2014 was 1.46 children per woman. Thus, if the age-specific fertility rates remain constant, a woman in Austria who is 15 years old today will, statistically speaking, have 1.46 children by her 50th birthday. This average lies significantly below the “maintenance level” of around 2 children per woman.”

Source: http://www.statistik.at/web_de/statistiken/menschen_und_gesellschaft/bevoelkerung/demographische_indikatoren/index.html [23.02.2016].

Task:

Determine the percentage by which the total fertility rate for 2014 of 1.46 children per woman would have to increase to meet the “maintenance level”.

percentage increase: _____ %

Task 14

Rates of Change of a Polynomial Function

The diagram below shows the graph of a polynomial function f .

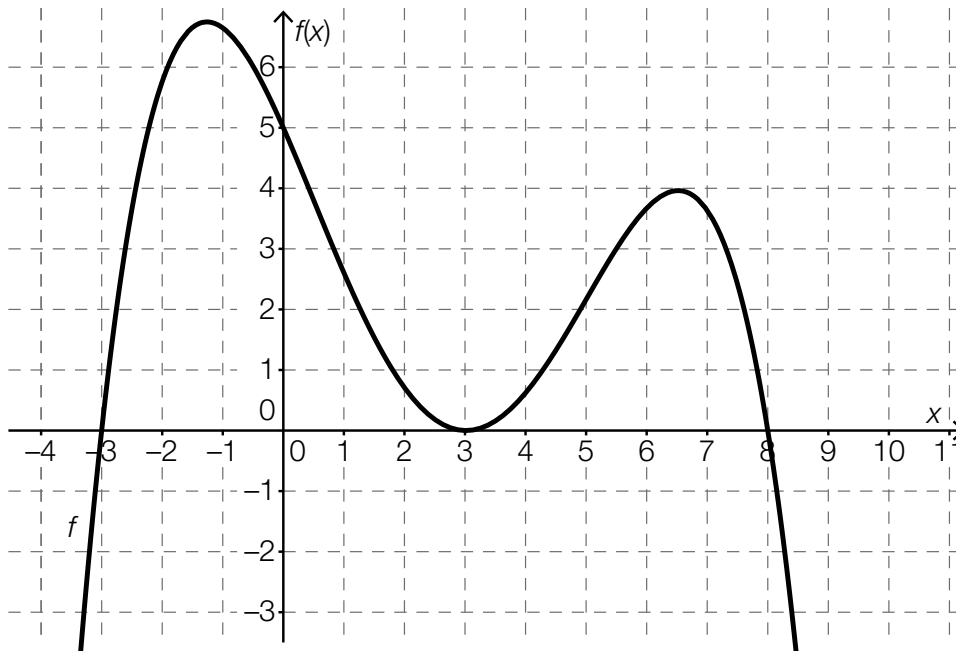

Task:

Put a cross next to each of the two correct statements.

The differential quotient at the point where $x = 6$ is larger than the differential quotient at the point where $x = -3$.	<input type="checkbox"/>
The differential quotient at the point where $x = 1$ is negative.	<input type="checkbox"/>
The difference quotient in the interval $[-3, 0]$ is 1.	<input type="checkbox"/>
The average rate of change is not 0 in any interval.	<input type="checkbox"/>
The difference quotient in the interval $[3, 6]$ is positive.	<input type="checkbox"/>

Task 15

Derivative and Antiderivative

Let f be a polynomial function and F one of its antiderivatives.

Task:

Put a cross next to each of the two correct statements.

A function F is an antiderivative of the function f if $f(x) = F(x) + c$ ($c \in \mathbb{R}$).	<input type="checkbox"/>
A function f' is a derivative of the function f if $\int f(x)dx = f'(x)$ holds.	<input type="checkbox"/>
If the function f is defined at x_0 , then $f'(x_0)$ gives the gradient of the tangent of the graph of f at this point.	<input type="checkbox"/>
The function f has infinitely many antiderivatives that only differ by an additive constant.	<input type="checkbox"/>
If the antiderivative F is integrated once, the function f is obtained.	<input type="checkbox"/>

Task 16

Properties of the Second Derivative

Graphs of five real functions are given below.

Task:

For which of the functions given does $f''(x) > 0$ hold in the interval $[-1, 1]$?
Put a cross next to each of the two correct graphs.

	<input type="checkbox"/>
	<input type="checkbox"/>
	<input type="checkbox"/>
	<input type="checkbox"/>
	<input type="checkbox"/>

Task 17

Area

A section of the graph of the polynomial function f where $f(x) = -\frac{x^3}{8} + 2 \cdot x$ is shown below.

The area between the graph of the function f and the x -axis in the interval $[-2, 2]$ is shaded in grey.

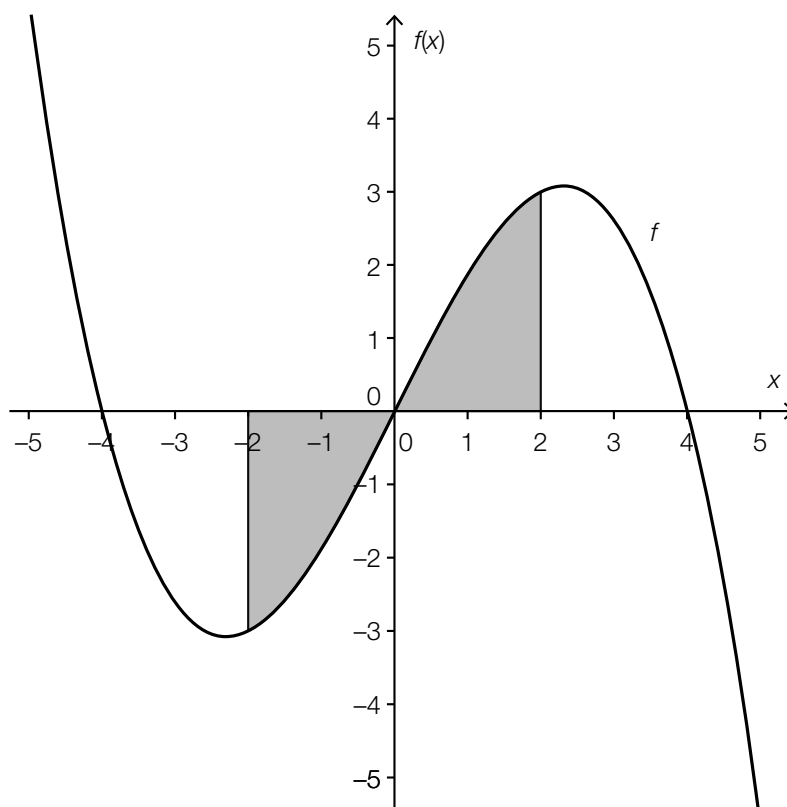

Task:

Determine the area of the region shaded in grey.

Task 18

Tachograph

Using a tachograph, the velocity of a vehicle in relation to time can be recorded. Let $v(t)$ be the velocity at time t .

The time is measured in hours (h) and the velocity in kilometres per hour (km/h).

A vehicle sets off at time $t = 0$.

Task:

Write down the meaning of the equation $\int_0^{0.5} v(t) dt = 40$ by using the correct units in the given context.

Task 19

Average Number of Missed Lessons

In a school there are four sport classes: S1, S2, S3 and S4. The table below gives an overview of the number of students per class as well as the corresponding mean of the number of missed lessons in the first semester of a school year.

Class	Number of Students	Mean Number of Missed Lessons
S1	18	45.5
S2	20	63.2
S3	16	70.5
S4	15	54.6

Task:

Determine \bar{x}_{ges} , the mean number of missed lessons of all four sport classes for the given time period.

Task 20

Coin Toss

In a random experiment, a coin with a number on one side and a crest on the other is thrown twice.

Task:

Write down all possible results of this experiment. In your answer, *crest* can be abbreviated by *W* and *number* by *Z*.

Task 21

Online Gambling

A man plays the same online gambling game regularly over a long period. The game has a constant probability of winning. Out of 768 games, the man wins 162 times.

Task:

What is the probability of the man winning the next game? Put a cross next to the correct estimate for this probability.

0.162 %	<input type="checkbox"/>
4.74 %	<input type="checkbox"/>
16.2 %	<input type="checkbox"/>
21.1 %	<input type="checkbox"/>
7.68 %	<input type="checkbox"/>
76.6 %	<input type="checkbox"/>

Task 22

Soft and Hard-Boiled Eggs

At the breakfast buffet of a hotel there are 10 eggs in a basket. From the outside, the eggs appear to be identical. During preparation, one hard-boiled egg was accidentally put with nine soft-boiled eggs.

Task:

A woman takes an egg at random out of the full basket. Determine the probability that the next guest randomly chooses a hard-boiled egg.

Task 23

Random Experiment

In a random experiment that is repeated 25 times, the results “favourable” and “unfavourable” are possible. The random variable X describes how often the result “favourable” comes up. X is binomially distributed with an expectation value of 10.

Task:

Two of the statements below can be deduced from this information. Put a cross next to each of the two correct statements.

$P(X = 25) = 10$	<input type="checkbox"/>
If the random experiment is repeated 25 times, 10 of the results will definitely be “favourable”.	<input type="checkbox"/>
The probability that a single random experiment is “favourable” is 40%.	<input type="checkbox"/>
If the random experiment is conducted 50 times, the expectation value for the number of “favourable” results is 20.	<input type="checkbox"/>
$P(X > 10) > P(X > 8)$	<input type="checkbox"/>

Task 24

Blood Group

In Europe, the probability of being born with blood group B is around 0.14. For a study, n people who were born in Europe are chosen at random. The random variable X describes the number of people with blood group B. The distribution of X can be approximated by a normal distribution whose probability density function is shown in the diagram below.

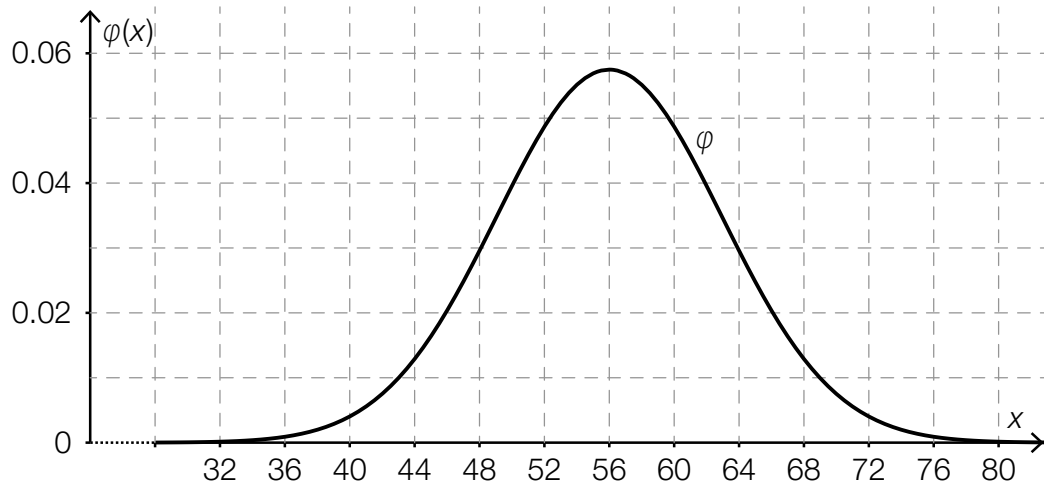

Task:

From the diagram above, estimate the sample size n of this study.

$n \approx$ _____